

CONTRACT DOCUMENTS,
STANDARD SPECIFICATIONS
AND SPECIAL PROVISIONS



Town of Hayden

Hospital Hill VCP Sewer Replacement

**CONTRACT DOCUMENTS,
STANDARD SPECIFICATIONS
AND
SPECIAL PROVISIONS**

FOR THE

**HOSPITAL HILL VCP
SEWER REPLACEMENT**

Prepared by:

**SUNRISE ENGINEERING, LLC
3001 South Lincoln Ave.,
Steamboat Springs, Colorado 80487
Tel: (970) 875-6719**

**CONTRACT DOCUMENTS,
STANDARD SPECIFICATIONS
AND SPECIAL PROVISIONS**

for the

HOSPITAL HILL VCP SEWER REPLACEMENT

TOWN REPRESENTATIVES

Mayor Ryan Banks
Town Manager Mathew Mendisco
Public Works Director..... Bryan Richards
Mayor Pro-Tem..... Trevor Gann
Council Member..... Ryan bell
Council Member..... Melinda Carlson
Council Member..... Camilla Haight
Council Member..... Danny Hayden
Council Member..... Elaine Hicks

Prepared by:

Sunrise Engineering, LLC
3001 South Lincoln Ave.
Steamboat Springs, Colorado 80487
Tel: (970) 875-6719

TABLE OF CONTENTS
FOR
TOWN OF HAYDEN
ADDENDUMS AND STANDARD SPECIFICATIONS FOR CONSTRUCTION

CONTRACT DOCUMENTS

Technical Bid Contents Form 399
Invitation to Bid..... Form 401
Instructions to Bidders..... Form 402
Bid Form 403
Bid Schedule..... Form 403a
Bid Bond Form 404
Construction Contract..... TOH0001
Performance Bond..... TOH0002
Payment Bond TOH0003
Notice of Award TOH0004
Notice to Proceed TOH0005
Notice of Substantial Completion..... Form 413
Notice of Final Acceptance Form 414

GENERAL INFORMATION (Town of Hayden)

Section A General Information 1
Section B Procurement for Public Infrastructure Improvements 6
Section C Engineering Services..... 3

DIVISION ONE – GENERAL REQUIREMENTS (Town of Hayden)

1031 Staking, Quantities, and As Constructed Measurements 8
1070 Cutting and Patching 2
1085 Applicable Standards 2
1300 Submittals and Substitutions 4
1410 Testing Laboratory Services..... 2
1500 Temporary Facilities and Controls 3
1562 Dust Control 2
1567 Erosion and Sediment Control 5
1570 Traffic Regulation 2
1600 Material, Equipment, and Workmanship 3
1710 Cleanup 2

DIVISION TWO – SITEWORK (Town of Hayden)

2211 Subgrade Construction 12
2221 Trenching, Bedding, and Backfill 8
2261 Riprap..... 1
2521 Culvert Pipe and Installation 4
2523 Manholes 6
2555 Water Distribution, Piping and Appurtenances 15
2560 Sewage Collection, Piping and Appurtenances 6
2565 Water and Sewer Line Crossings 3
2609 Gravel Surfacing 4

<u>Section</u>	<u>No. of Pages</u>
2612 Hot Mix Asphalt Pavement Superpave	15
2616 Pavement Removal and Replacement	3
2620 Curb, Gutter, Sidewalk and Concrete Pavement Trail Surfaces.....	11
2730 Street Signs	1
2821 Revegetation.....	5

TOWN OF HAYDEN DETAILS

Sheet 1	Trench Cross-Section and Pipe Embedment
Sheet 2	Water and Sewer Main Crossing Conditions
Sheet 3	Sewer Service
Sheet 4	Standard Manhole
Sheet 5	Drop Manhole
Sheet 6	Joint Restraint and Thrust Blocking
Sheet 7	Water Service Line
Sheet 8	Fire Hydrant
Sheet 9	Valve for PVC Main
Sheet 10	Watermain Air/Vacuum Valve and Manhole
Sheet 11	Meter Pit ¾" & 1"
Sheet 12	Pipe Encasement
Sheet 13	Concrete Gutters at Intersections
Sheet 14	Curb and Concrete Pan
Sheet 15	Catch Basin and Curb Inlet
Sheet 16	Insulated Pipe

CONTRACT DOCUMENTS

TECHNICAL BID CONTENTS

In case of conflict between the Drawings and Specifications, the Specifications shall govern. Figure dimensions on Drawings shall govern over scale dimensions, and detailed Drawings shall govern over general Drawings.

Bids shall include the following Three (3) items (A-C):

A. Form 403: Bid

- Company Name
- Business Type (corporation, partnership, or an individual)
- Acknowledgment of all addenda

B. Form 403a: Bid Schedule

- Unit Prices for bid items, and total amount for each bid item.
- Total Bid Amount
- Contractor Seal (if bid is by corporation)
- Bidder name, signature, title, and address

C. Form 404: Bid Bond

- Contractor's Name
- Surety's Name

INVITATION TO BID

Separate sealed bids for construction of Hospital Hill VCP Sewer Replacement will be received by The Town of Hayden from bidders.

Bids will be publicly opened and read aloud at 10:00 AM on Wednesday, January 15, 2025 at Hayden Town Hall, 178 West Jefferson Avenue, Hayden, CO 81639
(Time) (Date)

The work to be performed under this project shall consist of furnishing all labor, materials and equipment required to construct the facilities and features called for by the CONTRACT DOCUMENTS and as shown on the DRAWINGS.

Hospital Hill VCP Sewer Replacement

- Replacement of 625 feet of vitrified clay pipe and 4 manholes.
- Place new pipe by means of open trench for Spruce Street and Pine Street.
- Open trench will require pavement improvements.

This project is funded by The Town of Hayden.

Plans and specifications have been prepared by Sunrise Engineering, LLC and will be available after December 16th at <https://www.bidnetdirect.com/colorado/townofhayden>. And on the Town of Hayden's website <http://haydencolorado.com/bids-rfp/>. Notices regarding changes/amendments to the CONTRACT DOCUMENTS and DRAWINGS will uploaded to Bidnet Direct as necessary. Bidders are responsible to check the above Bidnet Link often to receive updates or additional documents/changes/amendments. The ENGINEER for this Contract will be Sunrise Engineering, LLC and they will be represented by Bryan Meier as Project Manager.

A mandatory pre-bid tour will be held on Wednesday, January 8th, 2025 at 10:00 a.m., leaving from the office of the Owner at Hayden Town Hall, 178 West Jefferson Avenue, Hayden, CO 81639.
(Date) (Time)

Names of those in attendance will be recorded.

INSTRUCTION TO BIDDERS

Complete sets of Bidding Documents may be obtained from Bidnet Direct as designated in the Advertisement or Invitation to Bid. Complete sets of Bidding Documents, which include the following 3 documents: 1) Contract Documents and Special Provisions, 2) Standard Specifications for Construction, and 3) Drawings, shall be used for preparing BIDS. Neither the OWNER nor ENGINEER assume any responsibility for errors or misinterpretations resulting from the use of incomplete sets of Bidding Documents.

Each BID must be submitted in a sealed envelope, addressed to: The Town of Hayden at 178 W Jefferson Ave, PO Box 190, Hayden, CO 81639. Each sealed envelope containing a BID must be plainly marked on the outside as "BID for Hayden Hospital Hill VCP Sewer Replacement" and the envelope should bear on the outside the name of the BIDDER, their address, license number if applicable, and the name of the project for which the BID is submitted. If forwarded by mail, the sealed envelope containing the BID must be enclosed in another envelope addressed to the OWNER at 178 W Jefferson Ave, PO Box 190, Hayden, CO 81639.

All BIDS must be made on the required BID form. All blank spaces for BID prices must be filled in, in ink or typewritten, and the BID form must be fully completed and executed when submitted. Only one copy of the BID form is required.

The OWNER may waive any informalities or minor defects or reject any and all BIDS. Any BID may be withdrawn prior to the scheduled time for the opening of BIDS or authorized postponement thereof. Any BID received after the time and date specified shall not be considered. No BIDDER may withdraw a BID within 60 days after the date of the BID opening. Should there be reasons why the contract cannot be awarded within the specified period, the time may be extended by mutual agreement between the OWNER and the BIDDER.

BIDDERS must satisfy themselves of the accuracy of the estimated quantities in the BID Schedule by examination of the site and a review of the drawings and specifications including ADDENDA. All bids will be checked by the ENGINEER for errors. If errors are made, unit prices shall govern and corrections will be made according to the unit price or lump sum amounts and totals will be revised to reflect the corrections.

The OWNER shall provide to BIDDERS prior to BIDDING, all information which is pertinent to, and delineates and describes, the land owned and rights-of-way acquired or to be acquired.

This WORK will be constructed by award of a competitive, sealed bid contract awarded to the lowest responsible, responsive bidder. Compensation to the CONTRACTOR will be made through progressive monthly payments in accordance with the General Conditions of these CONTRACT DOCUMENTS at the units and prices indicated in the BID Schedule.

When construction under this contract takes place on property owned or administered by agencies or organizations other than the OWNER, all construction shall be done in accordance with the special requirements of that entity which are contained or referenced in these CONTRACT DOCUMENTS

When requirements published by such entities are contained in, or referenced by, these CONTRACT DOCUMENTS, they shall be carefully complied with and the CONTRACTOR shall include sufficient compensation to cover the WORK required therein.

Information will be provided on the DRAWINGS and in these documents to indicate areas of WORK which fall on property owned or administered by agencies or organizations other than the OWNER.

The CONTRACT DOCUMENTS contain the provisions required for the construction of the PROJECT. Information obtained from an officer, agent, or employee of the OWNER or any other person shall not affect the risks or obligations assumed by the CONTRACTOR or relieve him from fulfilling any of the conditions of the contract.

Each BID must be accompanied by a BID BOND payable to the OWNER for five percent of the total amount of the BID. As soon as the BID prices have been compared, the OWNER will return the BONDS of all except the three lowest responsible, responsive BIDDERS. When the Agreement is executed, the bonds of the two remaining unsuccessful BIDDERS will be

returned. The BID BOND of the successful BIDDER will be retained until the PAYMENT BOND and PERFORMANCE BOND have been executed and approved, after which it will be returned. A certified check may be used in lieu of a BID BOND.

A PERFORMANCE BOND and a PAYMENT BOND, each in the amount of 100 percent of the CONTRACT PRICE, with a corporate surety approved by the OWNER, will be required for the faithful performance of the contract.

Attorneys-in-fact who sign BID BONDS or PAYMENT BONDS and PERFORMANCE BONDS must file with each BOND a certified and effective dated copy of their power of attorney.

The party to whom the contract is awarded will be required to execute the Agreement and obtain the PERFORMANCE BOND and PAYMENT BOND, when required, within ten (10) calendar days from the date when the NOTICE OF AWARD is delivered to the BIDDER. The NOTICE OF AWARD shall be accompanied by the necessary Agreement and BOND forms. In case of failure of the BIDDER to execute the Agreement, the OWNER may, at their option, consider the BIDDER in default, in which case the BID BOND accompanying the proposal shall become the property of the OWNER.

Within ten (10) days of receipt of the Agreement signed properly by the party to whom the contract was awarded, and accompanied by acceptable PERFORMANCE and PAYMENT BONDS, when required, the OWNER shall sign the Agreement and return to the BIDDER an executed duplicate of the Agreement. Should the OWNER not execute the Agreement within such period, the BIDDER may by WRITTEN NOTICE withdraw their signed Agreement. Such notice of withdrawal shall be effective upon receipt of the notice by the OWNER.

The NOTICE TO PROCEED shall be issued within ten (10) days of the execution of the Agreement by the OWNER. Should there be reasons why the NOTICE TO PROCEED cannot be issued within such period, the time may be extended by mutual agreement between the OWNER and CONTRACTOR. If the NOTICE TO PROCEED has not been issued within the ten (10) day period or within the period mutually agreed upon, the CONTRACTOR may terminate the Agreement without further liability on the part of either party.

The OWNER may make such investigations as deemed necessary to determine the ability of the BIDDER to perform the WORK and the BIDDER shall furnish to the OWNER all such information and data for this purpose as the OWNER may request. The OWNER reserves the right to reject any BID if the evidence submitted by, or investigation of, such BIDDER fails to satisfy the OWNER that such BIDDER is properly qualified to carry out the obligations of the Agreement and to complete the WORK contemplated therein.

A conditional or qualified BID will not be accepted.

BIDDER and OWNER recognize that time is of the essence in this Agreement and that OWNER will suffer financial loss if the WORK is not completed within the time period specified in the Bid. OWNER and BIDDER agree that as liquidated damages for delay (but not as a penalty) BIDDER shall pay OWNER the specified amount for each day that expires after the specified time for substantial completion until the WORK is substantially complete.

All applicable laws, ordinances, and the rules and regulations of all authorities having jurisdiction over construction of the PROJECT shall apply to the contract throughout.

The PROJECT will be awarded to the lowest responsible, responsive, base bidder subject to the following three (3) conditions:

1. The OWNER reserves the right to award all PROJECTS to the same BIDDER with the lowest cumulative base BID of all PROJECTS.
2. The OWNER reserves the right to award any individual PROJECT to the lowest responsible, responsive, base BIDDER based on that project's base BID.
3. The OWNER reserves the right to reject any or all BIDS from any individual PROJECT.

Each BIDDER is responsible for inspecting the site and for reading and being thoroughly familiar with the CONTRACT DOCUMENTS. The failure or omission of any BIDDER to do any of the foregoing shall in no way relieve any BIDDER from any obligation in respect to his BID.

The low BIDDER shall supply the names and addresses of major material SUPPLIERS and SUBCONTRACTORS when requested to do so by the OWNER.

BID

Bid of _____
(Insert Contractor's Name)
(hereinafter called "BIDDER"), organized and existing under the laws of the State of _____ and doing
business as _____ to
(Insert "a corporation", "a partnership" or "an individual" as applicable)
The Town of Hayden (hereinafter called "OWNER").

In compliance with the Invitation to Bid, BIDDER hereby proposes to perform all WORK for construction of the Hospital Hill VCP Sewer Replacement in strict accordance with the CONTRACT DOCUMENTS, within the time set forth therein, and at the prices stated below in the BID Schedule.

By submission of this BID, each BIDDER certifies, and in the case of a joint BID, each party thereto certifies as to their own organization, that this BID has been prepared independently, without consultation, communication, or agreement as to any matter relating to the BID with any other BIDDER or with any competitor.

BIDDER hereby agrees to commence WORK under this Contract on or before a date specified in the NOTICE TO PROCEED and to fully complete the CONTRACT within the provisions set by the Town of Hayden Construction Contract. BIDDER further agrees to pay liquidated damages as set by the Town of Hayden and specified in the Construction Contract. This BID will remain open for sixty (60) days after the date of Bid Opening. If awarded the Contract, the BIDDER will sign the Agreement and submit the security and the other documents required by the CONTRACT within ten (10) days after the date of the OWNER'S "Notice of Award".

BIDDER acknowledges receipt of the following ADDENDA:

The BID Schedule is provided on the following page. The BID Schedule must be completed in full by the BIDDER and signed properly to be considered responsible.

BID SCHEDULE

CONTRACT FOR: Hospital Hill VCP Sewer Replacement

The undersigned Bidder, having examined and determined the scope of the Contract Documents, hereby proposes to perform the work described herein for the following unit prices or lump sum amounts.

Note: 1. Bids shall include sales tax and all other applicable taxes and fees
 2. All bids shall be checked for errors. If errors are made, unit prices shall govern and corrections will be made according to the unit price and totals will be revised to reflect the corrections.

No.	Meas. & Pmt.	Item	Quantity	Unit	Unit Price	Amount
1		MOBILIZATION	1	LS		
2		POST CONSTRUCTION SEWER VIDEO	1	LS		
3	02221	IMPORTED TRENCH/STRUCTURAL BACKFILL	625	LF		
4		SUBSURFACE INVESTIGATION	6	EA		
5	02221	IMPORTED PIPE BEDDING MATERIAL	625	LF		
6	02560	INSTALL (8") (SDR 35) PIPE	625	LF		
7	02523	INSTALL 48" MANHOLE	2	EA		
8	02523	INSTALL 60" MANHOLE	2	EA		
9	02616	REMOVAL AND HAUL OF BITUMINOUS SURFACE	522	SY		
10	02616	REPLACE (4") BITUMINOUS SURFACE (CDOT GRADING SX PG 58-28 MIX WITH 20% OF RAP MAX)	522	SY		
11	02211	REPLACE BASE COURSE (CLASS 6)(10")	522	SY		
12	02211	REMOVE AND HAUL OF EXISTING BASE AND SUB-BASE MATERIAL	522	SY		
13		CONCRETE (4000-PSI)(8")	5	SY		
BASE BID TOTAL						

The undersigned Bidder certifies that this proposal is made in good faith, without collusion or connection with any other person or persons bidding on the work.

Seal (if bid is by Corporation)

Respectfully Submitted:

License No. _____

Bidder: _____

Date: _____

Signature _____

Title: _____

Address: _____

BID BOND

KNOW ALL MEN BY THESE PRESENTS, that we, the undersigned, _____
(Contractor's Name)

as Principal, and _____
(SURETY'S Name), as Surety, are hereby held and firmly bound unto The Town of Hayden as OWNER in the penal sum of _____

for the payment of which, well and truly to be made, we hereby jointly and severally bind ourselves, successors and assigns.

Signed this _____ day of _____, 20____.

The Condition of the above obligation is such that whereas the Principal has submitted to _____ a certain BID, attached hereto and hereby made a part hereof to enter into a contract in writing, for _____

NOW, THEREFORE,

- (a) If said BID shall be rejected, or
- (b) If said Bid shall be accepted and the Principal shall execute and deliver a contract in the Form of Contract attached hereto (properly completed in accordance with said BID) and shall furnish a bond or bonds as may be specified in the CONTRACT DOCUMENTS with surety acceptable to the OWNER and shall in all other respects perform the agreement created by the acceptance of said BID,

then this obligation shall be void, otherwise the same shall remain in force and effect; it being expressly understood and agreed that the liability of the Surety for any and all claims hereunder shall, in no event, exceed the penal amount of this obligation as herein stated.

The Surety, for value received, hereby stipulates and agrees that the obligations of said Surety and its BOND shall be in no way impaired or affected by any extension of the time within which the OWNER may accept such BID; and said Surety does hereby waive notice of any such extension.

IN WITNESS WHEREOF, the Principal and the Surety have hereunto set their hands and seals, and such of them as are corporations have caused their corporate seals to be hereto affixed and these presents to be signed by their proper officers, the day and year first set forth above.

(Principal) (L.S.)

(Name of Surety)

By: _____
(Signature)

IMPORTANT: Surety companies executing BONDS must appear on the Treasury Department's most current list (Circular 570 as amended) and be authorized to transact business in the state where the project is located.

TOWN OF HAYDEN CONSTRUCTION CONTRACT

1. PARTIES.

This Construction Contract (the "Contract"), dated as of _____, is between the Town of Hayden, a Colorado home rule town (hereinafter called "Town") by and through its Town Council (hereinafter called "Council"), and _____. (hereinafter called "Contractor"). For purposes of this Contract, the address of Town shall be P.O. Box190, Hayden, Colorado 81639

For purposes of this Contract, the address of Contractor shall be:

INSERT CONTRACTOR & ADDRESS HERE

2. WORK TO BE DONE BY CONTRACTOR.

The Work to be done by Contractor is detailed in the Contract Documents and itemized in the Bid Form, Section of those Contract Documents.

As used herein, the term "Project Administrator" shall refer to such person as the Council may, from time to time, designate as Town's representative. The Project Administrator for this project shall be the Public Works Director, Bryan Richards. Any changes in the designation of the Project Administrator shall be made in writing signed by the Town Manager and sent to Contractor at the address set forth in Section 1 above by U.S. Mail, first-class postage prepaid. It is intended, and hereby permitted, that the Project Administrator may delegate the responsibility for inspecting the work on the Project to other Town employees and agents but only the Project Administrator shall have the right and power to accept or reject work or materials on the Project or otherwise exercise the discretion of the Project Administrator provided for herein. For the purposes of this contract, the designated agents will be **INSERT ENGINEER**, and Bryan Richards, Public Works Director, Town of Hayden. **INSERT ENGINEER** will serve as the Engineer of record.

3. SCOPE OF WORK.

Contractor shall furnish all of the necessary supervision, materials, tools and supplies and perform all of the labor and other services necessary to complete the work set forth in the Contract Documents which is and referred to herein as the "Project."

All workmen shall be competent and have sufficient skill, knowledge and experience in their class of work and operation of equipment, to perform all work properly and satisfactorily.

Contractor agrees to do the work in a first class, substantial and workmanlike manner to the satisfaction of Town in strict accordance with the provisions of the Contract Documents.

Contractor shall complete all Work as specified or indicated in the Contract Documents. The Work is generally described as follows:

The Project consists of waterline and appurtenant improvements as described in the Contract Documents.

The Project for which the Work under the Contract Documents may be the whole or only a part is generally described as follows:

Hospital Hill VCP Sewer Replacement

4. TIME OF COMPLETION.

Contractor shall commence the work required by the Contract Documents within ten (10) days of receipt of the Notice to Proceed and shall achieve Substantial Completion of the Project within 90 calendar days after Notice to Proceed. The Project shall be complete and ready for final payment within 120 days after Notice to Proceed. Contractor agrees that the completion of the Project within the time as set forth herein is of the essence and agrees to proceed with due diligence, taking all precautions and making all necessary arrangements to ensure the completion of the work within the prescribed time period.

If Contractor refuses or fails to prosecute the work, or any separable part thereof, with such diligence as will ensure its completion within the time specified in this Contract, or any extension thereof, or fails to complete said work within such time, Town may, by written notice to Contractor, terminate his right to proceed with the work or such part of the work as to which there has been a delay. In such event, Town may take over the work and prosecute the same to completion, by contract or otherwise, and may take possession of and use any or all materials, appliances and plant as may be on the site of the work and necessary therefor.

Contractor's right to proceed shall not be so terminated nor Contractor charged with resulting damage if Contractor is delayed at any time in the progress of the work by any negligent act of Town, Town employee or agent, or by changes ordered in the work, or by strikes, lock-outs, fire, unusual delay in transportation, unavoidable casualties or other causes beyond Contractor's control. Inability to purchase the required materials listed in Contractor's Proposal shall not be considered to be "beyond Contractor's control."

If delay is due to a cause beyond Contractor's control, the time of completion of the work shall be extended for a period equal to such portion of the period of delay as Contractor shall be able to show he could not have avoided by exercise of due diligence; provided, however, that in no event shall the time for Contractor's completion of the Project be extended beyond October 31st, 2025. Contractor shall advise Town in writing within three (3) days from the beginning of such delay and shall file a written claim for an extension of time within seven (7) days after the period of delay has ceased.

Contractor and Town recognize that time is of the essence as stated in above and that Owner will suffer financial loss if the Work is not completed within the times specified above, plus any extensions thereof allowed. The parties also recognize the delays, expense, and difficulties involved in proving in a legal or arbitration proceeding the actual loss suffered by Town if the Work is not completed on time. Accordingly, instead of requiring any such proof, Town and Contractor agree that as liquidated damages for delay (but not as a penalty), Contractor shall pay Town \$1,500 for each day that expires after the time specified above for Substantial Completion until the Work is substantially complete. After Substantial Completion, if Contractor shall neglect, refuse, or fail to complete the remaining Work within the Contract Time or any proper extension thereof granted by Town, Contractor shall pay Town \$1,500 for each day that expires after the time specified above for completion and readiness for final payment until the Work is completed and ready for final payment.

5. COMPENSATION.

As consideration for the completion of the Project as required by the Contract Documents, Town shall pay to Contractor the sum of _____ which amount shall be payable as follows:

5.1. Progress payments shall be made upon application of Contractor to be made not more frequently than every month during the Project. Payments shall be based upon the cost of labor and materials incorporated in the Project and materials suitably stored on the site as estimated by Contractor and approved by the Project Administrator.

Progress payments will be made in an amount equal to the percentage indicated below but, in each case, less the aggregate of payments previously made and less such amounts as Engineer may determine or Town may withhold, including but not limited to liquidated damages.

- a. 95 percent of Work completed (with the balance being retainage).
- b. 95 percent of cost of materials and equipment not incorporated in the Work (with the balance being retainage).

5.2. At the time of an application for a progress payment, Contractor shall submit to the Project Administrator an itemized statement supported by receipts or vouchers showing payment for materials, labor and subcontracts; a description of the work completed; and Contractor's estimate of the percentage of completion of the Project represented by the payment application.

5.3. Within fifteen (15) days after receiving a complete application for progress payment and all required supportive information, Town shall pay to Contractor ninety-five percent (95%) of the amount shown in the application and approved by the Project Administrator. The remaining five percent (5%) shall be paid upon the issuance of the Certificate of Completion, and after advertisement of final payment

required by C.R.S. § 38-26-107 has been published and all applicable time periods under C.R.S. § 38-26-107 have expired.

5.4. If materials stored at the Project site are paid for by Town, title to such materials shall vest in Town. If such materials are stolen, lost or damaged before their incorporation into the Project, they shall be replaced at Contractor's sole expense.

6. IMMIGRATION COMPLIANCE.

Pursuant to House Bill 1343 and to Section 8-17.5-101, C.R.S., et seq., "Contractor" warrants, represents, acknowledges, and agrees that:

The Contractor shall not knowingly employ or contract with an illegal alien to perform work under this contract nor contract with any subcontractor that fails to certify to the Contractor that the subcontractor shall not knowingly employ or contract with an illegal alien to perform work under this contract.

The Contractor has verified or attempted to verify through participation in the E-Verify Program that the Contractor does not employ any illegal aliens. (For the purpose of this paragraph, "E-Verify Program" is defined to mean the employment verification program created in Public Law 208, 104th Congress, as amended, and expanded in Public Law 156, 108th Congress, as amended, that is administered by the United States Department of Homeland Security). If the Contractor is not accepted into the E-Verify Program prior to executing this contract, the Consultant shall apply to participate in the E-Verify Program every three months until the Contractor is accepted or this contract has been completed, whichever is earlier. The Contractor shall not use the E-Verify Program procedures to undertake pre-employment screening of job applicants while this contract is being performed. This paragraph shall not be effective if the E-Verify Program is discontinued.

If the Contractor obtains actual knowledge that a subcontractor performing work under this contract knowingly employs or contracts with an illegal alien, the consultant shall notify the subcontractor and the Town within three days that the Contractor has actual knowledge that the subcontractor is employing or contracting with an illegal alien; and terminate the subcontract with the subcontractor if within three days of receiving the notice required pursuant to this paragraph, the subcontractor does not stop employing or contracting with the illegal alien. The Contractor shall not terminate the contract with the subcontractor if during such three days the subcontractor provides information to establish that the subcontractor has not knowingly employed or contracted with an illegal alien.

The Contractor shall also comply with any reasonable request by the Colorado Department of Labor and Employment made in the course of an investigation that the department is undertaking pursuant to C.R.S. 8-17.5-102(2).

7. TAXES.

Construction and building materials sold to Contractor and subcontractors for use on structures, roads, streets, highways, and other public works owned by the Town of Hayden are exempt from Colorado sales and use taxes. However, such materials may be subject to any sales taxes imposed by local cities and counties and other local taxing authorities.

Contractor and subcontractors shall apply to the Colorado Department of Revenue for certificates of exemption indicating that their purchase of construction or building materials is for a public project. Completed copies of Application for Exemption Certificate with the approval of the Colorado Department of Revenue noted thereon should be delivered to Town prior to issuance of the Notice to Proceed. Contractor agrees to secure from each subcontractor copies of that subcontractor's approved Application and furnish a copy to Town.

8. INDEMNIFICATION AND INSURANCE.

Contractor shall indemnify and hold harmless Town, the Council and its agents and employees from and against any and all claims, damages, losses, injuries and expenses, including attorney's fees, arising out of or resulting from the performance of the work on the Project.

Contractor shall procure and maintain, at his own expense, until completion of all work and acceptance thereof by Town, all of the insurance coverages required below. Contractor shall furnish Town with a certificate of such insurance acceptable to Town. Such certificate shall be issued to Town and shall provide for ten (10) days written notice of cancellation or material change in coverage. The certificate shall be filed prior to the start of any work on the Project.

8.1. Liability Insurance. Contractor shall procure and maintain Comprehensive General Liability, including completed operations, contractual liability and automobile liability insurance affording coverage for all claims for bodily injury including death, and all claims for destruction of or damage to property, arising out of or in connection with any operations under this Contract, whether such operations be by Contractor or by subcontractors under him or anyone directly or indirectly employed by Contractor or by a subcontractor under him. Such insurance shall provide limits of liability of not less than one million dollars (\$1,000,000.00). Contractor shall furnish current certificates of insurance which shall include a provision that the insurance will not be canceled without ten (10) days prior notice to Town. All such insurance shall be written on a Comprehensive Form of Policy. All such insurance shall name Town as insured and Contractor as an additional insured.

8.2. Workman's Compensation Insurance; Unemployment Insurance; and Income Tax Withholding. Contractor shall procure and maintain Workman's Compensation Insurance at his own expense during the life of this Contract, including occupational disease provisions for all of his employees. Contractor shall also require each subcontractor to furnish Workman's Compensation Insurance, including occupational disease provisions for all of the latter's employees, otherwise he accepts full liability and responsibility for subcontractor's employees. In cases where any class of employees engaged in hazardous work under this Contract at the site of the Project is not protected under the Workman's Compensation statute, Contractor shall provide, and shall cause each subcontractor to provide, adequate and suitable

insurance for the protection of his employees not otherwise protected. Neither the Contractor nor any employee of Contractor shall be entitled to unemployment insurance benefits through the Town and the Contractor shall be obligated to pay any federal or state income taxes due with respect to any sum payable by Town hereunder.

9. SUBLETTING OF CONTRACT.

Contractor shall not sublet, sell, transfer, assign or otherwise dispose of this Contract, or of his right, title or interest therein, without the written consent of Town, which consent may be withheld without cause.

Contractor may utilize the services of specialty subcontractors on those parts of the Project which, under normal contracting practices, are performed by specialty subcontractors.

Contractor shall not award work to subcontractors in excess of fifty percent (50%) of the contract price without prior written approval of Town.

Contractor shall be fully responsible to Town for the acts and omissions of his subcontractors and of persons directly employed by them, as he is for the acts and omissions of persons directly employed by him.

Contractor shall cause appropriate provisions to be inserted in all subcontracts relative to the Project to bind the subcontractors to Contractor by the terms of the Contract Documents and to give Contractor the same power as regard terminating any subcontract that Town may exercise over Contractor under any provision of the Contract Documents.

Nothing contained in this Contract shall create any contractual relationship between any subcontractor and Town.

10. WARRANTY.

Contractor warrants to Town that all equipment and materials to be furnished under this Contract shall be free from all defects in workmanship and materials.

Contractor shall remove from the Project area all work or materials rejected by the Project Administrator for failure to comply with the Contract Documents, whether incorporated in the construction or not. Contractor shall promptly replace the materials or re-execute the work in accordance with the Contract Documents and without expense to Town which are or become defective due to such defects within two (2) years after date of receipt by Town. Contractor shall also bear the expense of making good all work of other contractors destroyed or damaged by such removal or replacement.

Should Contractor fail to proceed promptly in accordance with this warranty, Town may have such work performed at the expense of Contractor.

11. PRE-CONTRACT EXAMINATION.

Before submitting his Bid, Contractor examined all of the work to be done as described in the Contract Documents and became well and fully informed as to the materials and character of work required, the relationship of all the particular parts of the work.

After execution of this Contract, no consideration will be granted for any misunderstanding of the materials to be furnished or the work to be done, it being mutually understood that the tender of the proposal carried with it an agreement to this end and all other conditions mentioned in this Contract and the Bid, and implied a full and complete understanding of them.

Should anything be omitted from the Construction Plans or Specifications necessary to the proper completion of the work herein described, it shall be the duty of Contractor to so notify Town before signing this Contract, and in the event of the failure of Contractor to give such notice, he shall make good any damage or defect in his work caused thereby without extra charge. No allowance will be made for lack of full knowledge of all conditions, except such underground conditions as are determined after commencement of the work and were unknown to Contractor.

12. ACCESS AND INSPECTION.

Town and the Project Administrator shall at all times have access to the work. Contractor shall provide proper facilities for such access and for inspection of the work. The Project Administrator is, in the first instance, the judge of the performance of the Contract as it relates to compliance with the Proposal, quality of workmanship and material.

All materials and equipment used in the construction of the Project shall be subject to adequate inspection and testing in accordance with generally accepted standards, as required and defined in the Contract Documents.

The Project Administrator may order that portions of the work be uncovered, exposed or made available for observations, inspection or testing. Contractor shall provide all necessary labor, materials, tools and equipment to comply with the Project Administrator's order. If such portion of the work is determined to be defective, Contractor shall bear all costs involved, including the cost of reconstruction. If such portion of the work is determined to be in substantial compliance with the Proposal, Contractor shall be compensated in accordance with Section 16 ******(Changes and Additional Work).

13. MEASUREMENTS.

Contractor shall verify all measurements for unit bid price items at the site. All dimensions shown for existing work and all dimensions required for work that is to connect with work now in place shall be verified by Contractor by actual measurement of the existing work. Any discrepancies between the contract requirements and the existing conditions shall be referred to the Project Administrator before any work affected thereby has been performed. No compensation will be allowed for differences between actual

dimensions and those indicated on the Proposal. Differences shall be submitted to the Project Administrator for consideration before proceeding with work, and in the event of the failure of Contractor to so notify the Project Administrator, Contractor shall make good any damage or defect in this work caused thereby, without extra charge to Town.

14. NON-DISCRIMINATION.

During the performance of this Contract, Contractor agrees as follows:

14.1. Contractor will not discriminate against any employee or applicant for employment because of race, creed, color, national origin, sex, marital status, religion, ancestry, mental or physical handicap, or age. Contractor will take affirmative action to insure that applicants are employed, and that employees are treated during employment, without regard to the above mentioned characteristics. Such action shall include, but not be limited to the following: employment, upgrading, demotion, or transfer, recruitment or recruitment advertising; lay-offs or terminations; rates of pay or other forms of compensation; and selection for training, including apprenticeship. Contractor agrees to post in conspicuous places, available to employees and applicants for employment, notices to be provided by Contractor setting forth provisions of this non-discrimination clause.

14.2. Contractor will, in all solicitations or advertisements for employees placed by or on behalf of Contractor, state that all qualified applicants will receive consideration for employment without regard to race, creed, color, national origin, sex, marital status, religion, ancestry, mental or physical handicap, or age.

15. PROTECTION OF WORK AND PROPERTY.

Contractor shall continuously maintain adequate protection of his work and materials, protect the property on which the Project is to be constructed from injury or loss arising in connection with the Contract and adequately protect adjacent property as provided by law and Contract Documents.

Contractor shall at all times conduct his work so as to assure the least possible obstruction to traffic and adjacent residents. The safety and the protection of persons and property of the general public and residents along the street, highway and areas adjacent to the work shall be provided for by Contractor.

Contractor shall make good any damage, injury or loss, except such as may be:

- a. directly due to errors in the Proposal;
- b. caused by agents or employees of Town; or
- c. due to causes beyond Contractor's control and not due to his fault or negligence.

Contractor shall take all necessary precautions for the safety of employees on the work and shall comply with all applicable provisions of federal, state, municipal, Town or any other political subdivision's safety laws and building codes to prevent accident or injury to persons on, about or adjacent to the premises where the work is being performed. He shall erect and properly maintain at all times, as required by the conditions and progress of the work, all necessary safeguards for the protection of workmen and the public and, if necessary, shall take all other action necessary to assure the safe passage of pedestrians and automobiles.

16. CHANGES AND ADDITIONAL WORK.

Town may order changes within the scope of the work without invalidating this Contract. Such changes shall not require work beyond the geographical limits of the original Project unless the Contract is modified. An increase or decrease in the unit cost or completion time requires an equitable adjustment and a change order shall be authorized by the Project Administrator.

No deviations from the Proposal will be permitted except those specifically authorized by a written change order issued and signed by the Project Administrator. Any completely executed change order shall be considered authorization to proceed with the additional work. If Contractor proceeds without this authorization, he shall forfeit any claim for additional compensation for the work so performed.

If Town deems it expedient to correct damaged work or work not performed in accordance with this Contract, an equitable deduction from the contract price may be authorized by change order.

17. PARTIAL ACCEPTANCE.

During the prosecution of the Project, Contractor may substantially complete a unit or portion of the Project. Contractor may request Town's Project Administrator to make a final inspection of that portion of the Project. If the Project Administrator finds, upon inspection, that the work has been satisfactorily completed in compliance with the Contract Documents, he shall accept the work as being completed and Contractor shall be relieved of further responsibility for that work. Such partial acceptance shall in no way void or alter any terms of this Contract.

18. FINAL INSPECTION, ACCEPTANCE AND SETTLEMENT.

When the work is complete and ready for final inspection, Contractor shall file a written notice with the Project Administrator that the work, in the opinion of Contractor, is complete under the terms of this Contract.

Within ten (10) days after Contractor files written notice that the work is complete, the Project Administrator and Contractor shall make a "final inspection" of the Project to determine whether the work has been completed in accordance with the Contract Documents. A final list shall be made by the Project Administrator in sufficient detail to fully outline to Contractor:

- a. Work to be completed, if any;
- b. Work not in compliance with the Bid, Drawings or Specifications, if any; and
- c. Unsatisfactory work for any reason, if any.

Four (4) copies of the list will be counter-signed by the Project Administrator and will then be transmitted to Contractor (two copies) and Town (two copies).

Town shall not authorize final payment until all items on the list have been completed, a certificate of completion issued, and the notice of final payment as required by C.R.S. § 38-26-107 has been published and all applicable time periods under C.R.S. § 38-26-107 have expired.

Before Town is required to advertise, Contractor shall deliver to Town all guarantees and warranties, all statements to support Colorado sales and use tax refunds, if applicable, one (1) set of as-built drawings showing all job changes, and demonstrate to the operating personnel of Town the proper operation and maintenance of all equipment which is a part of the Project.

Upon completion of the foregoing, the Project shall be advertised by a notice of Contractor's settlement by two (2) publications of the notice, the last publication appearing at least ten (10) days prior to the time of final settlement. On the date of final settlement thus advertised, and after Contractor has submitted a written notice to Town that no claims have been filed, payment and settlement shall be made as provided in C.R.S. § 38-26-107.

If any unpaid claim for labor, materials, supplies, equipment or damages to third parties filed before payment in full of all sums due Contractor, Town shall withhold from Contractor sufficient funds to insure the payment of such claim until the same shall have been paid or withdrawn, such payment or withdrawal evidenced by filing a receipt in full or an order for withdrawal signed by the claimant or his duly-authorized agent or assignee.

19. CANCELLATION OF CONTRACT.

Failure of Contractor to comply with any of the requirements of this Contract and the Specifications may be considered as evidence of the inability on the part of Contractor to maintain the quality and service standards deemed necessary and shall be sufficient cause for the cancellation of this Contract.

20. ATTORNEY FEES.

In the event either party to this Contract brings suit to enforce or interpret any portion of this Contract, the party substantially prevailing in such action shall be entitled to recover all costs incurred in such action, including without limitation reasonable attorney's fees.

21. INTEGRATION; VENUE AND JURISDICTION.

This Contract shall be binding on and inure to the benefit of the parties hereto, their respective successors and assigns, and shall not be deemed to be for the benefit of or enforceable by any third party. This Contract constitutes the entire agreement between the parties concerning the work described in the Scope of Work and may not be amended except by a written document executed by both parties hereto. This Contract shall be governed by and construed in accordance with the internal laws of the State of Colorado without reference to choice of laws rules. The parties hereby agree that venue and jurisdiction for all actions taken with respect to this Contract shall be in the Routt County District Court in Steamboat Springs, CO.

22. LIMITATION ON SPENDING- In accordance with §24-91-103.6(2) C.R.S., the Town makes the following statements:

22.1. The amount of money appropriated by the Town is equal to or in excess of the Compensation described above.

22.2. No change order or other form of order or directive can be issued by the Town, which requires additional compensable work to be performed, which work causes the aggregate amount payable under the contract to exceed the amount of the Compensation described above, unless the Contractor is given written assurance by the Town that lawful appropriations to cover the costs of the additional work have been made, or unless such work is covered under a remedy granting provision in this Contract.

Town of Hayden

ATTEST:

Town Clerk

By: _____
Mayor, Town of Hayden

INSERT COMPANY NAME HERE

By: _____
Title: Owner

PERFORMANCE BOND

KNOW ALL MEN BY THESE PRESENTS: that

(Name of Contractor)

(Address of Contractor)

a _____, hereinafter called Principal, and
(Corporation, Partnership, or Individual)

(Name of Surety)

(Address of Surety)

hereinafter called Surety, are held and firmly bound unto

(Name of Owner)

(Address of Owner)

hereinafter called OWNER, in the penal sum of _____ Dollars,

\$(_____) in lawful money of the United States, for the payment of which sum well and truly to be made, we bind ourselves, successors, and assigns, jointly and severally, firmly by these presents.

THE CONDITION OF THIS OBLIGATION is such that whereas, the Principal entered into a certain contract with the OWNER, dated the _____ day of _____, 20____, a copy of which is hereto attached and made a part hereof for the construction of:

NOW, THEREFORE, if the Principal shall well, truly and faithfully perform its duties, all the undertakings, covenants, terms, condition, and agreements of said contract during the original term thereof, and any extensions thereof which may be granted by the OWNER, with or without notice to the Surety and during the one year guaranty period, and if he shall satisfy all claims and demands incurred under such contract, and shall fully indemnify and save harmless the OWNER from all costs and damages which it may suffer by reason of failure to do so, and shall reimburse and repay the OWNER all outlay and expense which the OWNER may incur in making good any default, then this obligation shall be void; otherwise to remain in full force and effect.

PROVIDED, FURTHER, that all the said Surety, for value received hereby stipulates and agrees that no change, extension of time, alteration or addition to the terms of the contract or to WORK to be performed thereunder or the SPECIFICATIONS accompanying the same shall in any wise affect its obligation on this

PAYMENT BOND

KNOW ALL MEN BY THESE PRESENTS: that

(Name of Contractor)

(Address of Contractor)

a _____, hereinafter called Principal, and
(Corporation, Partnership, or Individual)

(Name of Surety)

(Address of Surety)

hereinafter called Surety, are held and firmly bound unto

(Name of Owner)

(Address of Owner)

hereinafter called OWNER, in the penal sum of _____ Dollars,

\$(_____) in lawful money of the United States, for the payment of which sum well and truly to be made, we bind ourselves, successors, and assigns, jointly and severally, firmly by these presents.

THE CONDITION OF THIS OBLIGATION is such that whereas, the Principal entered into a certain contract with the OWNER, dated the _____ day of _____, 20____, a copy of which is hereto attached and made a part hereof for the construction of:

NOW, THEREFORE, if the Principal shall promptly make payment to all persons, firms, SUBCONTRACTORS, and corporations furnishing materials for or performing labor in the prosecution of the WORK provided for in such contract, and any authorized extension or modification thereof, including all amounts due for materials, lubricants, oil, gasoline, coal and coke, repairs on machinery, equipment and tools, consumed or used in connection with the construction of such WORK, and all insurance premiums on said WORK, and for all labor, performed in such WORK whether by SUBCONTRACTOR or otherwise, then this obligation shall be void; otherwise to remain in full force and effect.

PROVIDED, FURTHER, that all the said surety, for value received hereby stipulates and agrees that no change, extension of time, alteration or addition to the terms of the contract or to WORK to be performed thereunder or the SPECIFICATIONS accompanying the same shall in any wise affect its obligation on this BOND, and it does hereby waive notice of any such change, extension of time, alteration or addition to the terms of the contract or to the WORK or to the SPECIFICATIONS.

PROVIDED, FURTHER, that no final settlement between the OWNER and the CONTRACTOR shall abridge the right of any beneficiary hereunder, whose claim may be unsatisfied.

IN WITNESS WHEREOF, this instrument is executed in _____ counterparts, each one of which shall be
(number)
deemed an original, this the _____ day of _____, 20__.

ATTEST:

(Principal)

By _____

(SEAL)

(Address)

(Witness as to Principal)

(Address)

ATTEST:

(Surety)

(Witness as to Surety)

By _____
(Attorney-in-Fact)

(Address)

(Address)

NOTE: Date of BOND must not be prior to date of Contract.

If CONTRACTOR is Partnership, all partners should execute BOND.

IMPORTANT: Surety companies executing BONDS must appear on the Treasury Department's most current list (Circular 570 as amended) and be authorized to transact business in the state where the PROJECT is located.

NOTICE OF AWARD

TO: _____

PROJECT DESCRIPTION: Hospital Hill VCP Sewer Replacement

The TOWN has considered the BID submitted by you for the above described WORK in response to its Advertisement for Bids dated _____ and Information for Bidders.

You are hereby notified that your BID has been accepted for items in the amount of _____.

You are required by the Information for Bidders to execute the Agreement and furnish the required CONTRACTOR'S certificates of Insurance within ten (10) calendar days from the date of this Notice to you.

If you fail to execute said Agreement and to furnish said certificates within ten (10) days from the date of this Notice, TOWN will be entitled to consider all your rights arising out of the OWNER'S acceptance of your BID as abandoned. The TOWN will be entitled to such other rights as may be granted by law.

You are required to return an acknowledged copy of this NOTICE OF AWARD TO THE TOWN .

Dated this ____ day of _____, 2025.

The Town of Hayden

By: Bryan Richards, Public Works Director

ACCEPTANCE OF NOTICE

Receipt of the above NOTICE OF AWARD is hereby acknowledged.

By: _____

This _____ day of _____, 2025

By: _____

Title: _____

BOND, and it does hereby waive notice of any such change, extension of time, alteration or addition to the terms of the contract or to the WORK or to the SPECIFICATIONS.

PROVIDED, FURTHER, that no final settlement between the OWNER and the CONTRACTOR shall abridge the right of any beneficiary hereunder, whose claim may be unsatisfied.

IN WITNESS WHEREOF, this instrument is executed in _____ counterparts, each one of which shall be deemed an original, this the _____ day of _____, 20____.

ATTEST:

(Principal)

By _____

(SEAL)

(Address)

(Witness as to Principal)

(Address)

ATTEST:

(Surety)

(Witness as to Surety)

By _____
(Attorney-in-Fact)

(Address)

(Address)

NOTE: Date of BOND must not be prior to date of Contract.

If CONTRACTOR is Partnership, all partners should execute BOND.

IMPORTANT: Surety companies executing BONDS must appear on the Treasury Department's most current list (Circular 570 as amended) and be authorized to transact business in the state where the PROJECT is located.

NOTICE TO PROCEED

To:

Date: _____

Project:

You are hereby notified to commence WORK on or before _____, 2025, in accordance with the Agreement dated _____, 2025, and you are to complete ALL ASPHALT WORK BY September 30, 2025. The date of completion for all OTHER WORK BY October 31, 2025.

TOWN OF HAYDEN

By: Bryan Richards, Public Works Director

ACCEPTANCE OF NOTICE

Receipt of the above NOTICE TO PROCEED is hereby acknowledged by _____

_____ this _____ day of _____, 2025.

By: _____

Title: _____

Employer Identification Number: _____

NOTICE OF SUBSTANTIAL COMPLETION

Project: Hospital Hill VCP Sewer Replacement

Owner: The Town of Hayden

To: CONTRACTOR

Name: _____

Address: _____

This Notice of Substantial Completion applies to all work included under the Contract Documents or to the following specified parts thereof:

- Replacement of 625 feet of vitrified clay pipe and 4 manholes.
- Place new pipe by means of open trench for Spruce Street and Pine Street.
- Open trench will require pavement improvements.

The work described above and performed under this Contract has been reviewed and found substantially complete and the date of SUBSTANTIAL COMPLETION for this work is hereby established as: _____. The guarantee period shall commence on this date.

Definition of Date of Substantial Completion: That Date certified by the ENGINEER/ARCHITECT when the construction of the PROJECT, or a specified part thereof, is sufficiently completed in accordance with the CONTRACT DOCUMENTS so that the PROJECT, or specified part, can be utilized for the purpose for which it is intended.

A list of items to be completed or corrected, which are connected to or affected by the work described above, is attached hereto. The failure to include any items on such list does not alter the responsibility of the CONTRACTOR to complete all work in accordance with the CONTRACT DOCUMENTS. The date of commencement of guarantee for items in the attached list will be the date of final acceptance, unless agreed otherwise in writing.

Town of Hayden

Public Works Director

Date

Receipt of this notice is hereby acknowledged:

Contractor's Name

By: _____

Signature

Date

<h1>NOTICE OF FINAL ACCEPTANCE</h1>

To: _____
Contractor's Name

Address

RE: Hospital Hill VCP Sewer Replacement

OWNER: The Town of Hayden

A final inspection of the WORK completed under the Contract indicated above has been made and all WORK has been found to be completed. All known changes to the WORK have been documented and approved at this time and to the best of our knowledge, information and belief. The work required by this Contract has been performed and completed in accordance with the approved DRAWINGS, SPECIFICATIONS and other CONTRACT DOCUMENTS. Final payment for the Contract has therefore been requested and should follow shortly.

Thank you for your effort and cooperation towards the successful completion of this WORK.

ENGINEER: _____
Signature

Date: _____

OWNER'S Representative: _____
Signature

Date: _____

STANDARD SPECIFICATIONS

TOWN OF HAYDEN STANDARD SPECIFICATIONS AND DETAILS

January, 2019



178 W. Jefferson Ave.
P.O. Box 190
Hayden, CO 81639
Office: 970-276-3741



TABLE OF CONTENTS

I. General Information

- A. General Information
- B. Procedure for Public Infrastructure Improvements
- C. Engineering Services

II Specifications

Division One General Requirements

- 1031 Staking, Quantities, and As Constructed Measurements
- 1070 Cutting and Patching
- 1085 Applicable Standards
- 1300 Submittals and Substitutions
- 1410 Testing Laboratory Services
- 1500 Temporary Facilities and Controls
- 1562 Dust Control
- 1567 Erosion and Sediment Control
- 1570 Traffic Regulation
- 1600 Material, Equipment, and Workmanship
- 1710 Cleanup

Division Two Site Work

- 2211 Subgrade Construction
- 2221 Trenching, Bedding, and Backfill
- 2261 Riprap
- 2521 Culvert Pipe and Installation
- 2523 Manholes
- 2555 Water Distribution, Piping and Appurtenances
- 2560 Sewage Collection, Piping and Appurtenances
- 2565 Water and Sewer Line Crossings
- 2609 Gravel Surfacing
- 2612 Hot Mix Asphalt Pavement Superpave
- 2616 Pavement Removal and Replacement
- 2620 Curb, Gutter, Sidewalk and Concrete Pavement Trail Surfaces
- 2730 Street Signs
- 2821 Revegetation

III Details

- Sheet 1 Trench Cross-Section and Pipe Embedment
- Sheet 2 Water and Sewer Main Crossing Conditions
- Sheet 3 Sewer Service
- Sheet 4 Standard Manhole
- Sheet 5 Drop Manhole
- Sheet 6 Joint Restraint and Thrust Blocking
- Sheet 7 Water Service Line
- Sheet 8 Fire Hydrant
- Sheet 9 Valve for PVC Main
- Sheet 10 Watermain Air/Vacuum Valve and Manhole
- Sheet 11 Meter Pit ¾" & 1"
- Sheet 12 Pipe Encasement
- Sheet 13 Concrete Gutters at Intersections
- Sheet 14 Curb and Concrete Pan
- Sheet 15 Catch Basin and Curb Inlet
- Sheet 16 Insulated Pipe



SECTION A GENERAL INFORMATION

The specifications which follow cover the technical requirements for completing the work, and the procedures for obtaining Town of Hayden acceptance of the work.

The contract form, terms and conditions shall be provided separately on work contracted by the Town of Hayden and shall be as negotiated between the Owner and Contractor for development work to be accepted by the Town of Hayden.

The specifications include provisions for measurement and payment; these provisions may be used when specified by the Town of Hayden or project Owner.

The term "Engineer" in the specifications shall refer to the Town of Hayden or the Town of Hayden's Engineer, for work contracted by the Town of Hayden or the Owner's Engineer, for Development work to be accepted by the Town of Hayden.

The term "Owner" in the specifications shall refer to the Town of Hayden, for work contracted by the Town of Hayden or the Development Project Owner, for Development work to be completed by the Town of Hayden.

Staking, quantities and as-constructed measurement responsibilities for Development work may be as negotiated between the Owner, Development Project Owner and the Contractor.



SECTION B PROCEDURE FOR PUBLIC INFRASTRUCTURE IMPROVEMENTS

All work shall comply with the requirements of applicable laws/codes and ordinances.

Review of the public infrastructure improvements (roads, drainage, sidewalks, trails, water and wastewater facilities) shall proceed as follows. Each project is evaluated on a case-by-case basis and additional requirements may be required of individual projects.

A. DEVELOPMENT REVIEW (For Development Projects Only)

The review of public roads, trails, water and wastewater extensions is performed in conjunction with the Town of Hayden planning process. Preliminary engineered road, drainage and utility plans are required and will be reviewed in context to the other submitted plans such as site, grading and landscaping plans.

B. APPROVAL OF CONSTRUCTION DRAWINGS (For Development Projects Only)

Engineered road, drainage and water and sewer utility plans are required for any road and water or sewer main line extension, whether public or private. The construction plans and specifications shall be prepared by an engineer registered in the state of Colorado. Plans should be submitted to allow adequate time for review and revisions, prior to the start of any construction.

Specifications: The project specifications shall be the Town of Hayden, STANDARD SPECIFICATIONS AND DETAILS. The design engineer is responsible for determining the suitability and completeness of The Standard Specifications and Details and for providing Supplemental Specifications, details, special provisions, etc. to adequately address all aspects of the proposed work.

Drawings: The drawing set must include, as a minimum; a site plan, grading and drainage plan, road plan and profile, water and wastewater plan, wastewater main profile sheet, detail sheet, a dry utility plan with the wet utilities shown, and a landscape plan with wet utilities and easements shown. In addition, a profile must be provided for all existing water or wastewater mains, which are impacted by any grading, proposed as part of the project. See Checklist of the Town of Hayden Construction Plan and Specification Requirements.

For initial review, two sets of plans and specifications should be submitted. One set may be red lined for revision and returned to the engineer to make the needed revisions. Two or more final stamped sets should be submitted along with the original red lined drawings.

C. PRE-CONSTRUCTION MEETING

Prior to commencing construction, a pre-construction meeting is required to be held between the project engineer, the contractor and a representative from the Town of Hayden.

The following items will be reviewed and discussed:

- a) Review the staking and alignment
- b) Inspect the materials and discuss any substitutions
- c) Review the inspection requirements (both by the project engineer and the Town of Hayden)
- d) Review the test Procedures
- e) Insure the contractor has a current set of the Town of Hayden, STANDARD SPECIFICATIONS AND DETAILS
- f) Any other topics relevant to the project



D. CONSTRUCTION

Any changes to the approved plans and specifications shall be approved by the Town of Hayden in writing prior to implementation.

Any use of geotextiles for roadway subgrade stabilization shall be approved by the Town of Hayden in writing prior to installation. If the Engineer observes work being completed by the contractor not to specification and is not corrected upon request, the Engineer is to immediately notify the Town of Hayden.

The project engineer or a representative from the Town of Hayden is required to inspect every live tap.

All required submittals shall be submitted and approved prior to construction. Any variations to specifications shall be approved by the Town of Hayden prior to installation.

For Development projects, the Development Owner is required to hire a qualified engineer who shall provide construction engineering services as outlined in Section C, Engineering Services.

E. PRELIMINARY ACCEPTANCE

For Development projects, the Development Owner is required to enter into an Improvements Agreement with the Town of Hayden which requires that the Town of Hayden inspect all work prior to the Town of Hayden approval and/or acceptance of the project.

The Contractor shall comply with the requirements of the Town of Hayden as necessary to insure that the Town of Hayden will approve and/or accept the completed work.

The following procedure shall be followed:

1. Letter Requesting Preliminary Acceptance Inspection

When the project is complete the Development Owner or Contractor shall submit a letter to the Town of Hayden requesting preliminary acceptance inspection. All grading is to be complete prior to inspection. The Letter Request is to have attached all required support data including:

- Daily observation logs
- Draft record documents
- Engineers construction report
- Copies of all quality control testing and observations

For new roadways, the final pavement lift shall be placed approximately one year following initial paving.

2. Town Scheduled Inspection

The Town will schedule a joint inspection with the Town of Hayden, Engineer, and Contractor in attendance. If the joint inspection by the Town of Hayden, Engineer, and Contractor reveals deficiencies, the Town of Hayden and Engineer shall prepare a punch list of corrections to be completed.



3. Deficiencies, Corrections and Re-inspection

The Contractor shall immediately correct all deficiencies on the punch list and submit a Letter requesting a re-inspection to the Town of Hayden. If the second inspection reveals that the corrections are not satisfactory, the process shall be repeated until all deficiencies have been satisfactorily completed.

4. Certificate of Substantial Completion

Once the Town is satisfied that the deficiencies have been corrected, the Town of Hayden will issue a Certificate of Substantial Completion to the Development Owner or Contractor. Substantial completion for roadways requires completion of final pavement lift.

5. Letter of Preliminary Acceptance

A letter of Preliminary Acceptance will not be issued by the Town of Hayden until Record Drawings are approved and all easements are recorded. Preliminary acceptance allows for the extension of service lines to buildings and service connection.

F. WARRANTY

The Development Owner or Contractor, (Town of Hayden Projects) shall guarantee all materials and equipment furnished and WORK performed for a period of one (1) year from the date of SUBSTANTIAL COMPLETION or until all requirements for Final Project Acceptance are completed. The same party warrants and that the completed system is free from all defects due to faulty materials or workmanship and the Party shall promptly make such corrections as may be necessary by reason of such defects including the repairs of any damage to other parts of the system resulting from such defects. The Town of Hayden will give notice of observed defects with reasonable promptness. In the event that the Party should fail to make such repairs, adjustments, or other WORK that may be made necessary by such defects, the Town of Hayden may do so and charge the Party the cost thereby incurred.

Upon written request, the Town of Hayden may allow and permit temporary water and sanitary sewer services to the improvements during the period of construction of the improvements, provided that the new mains have passed pressure and biological testing.

G. FINAL ACCEPTANCE

1. Final Project Acceptance Inspection

One year following Preliminary Acceptance, the Development Owner or Contractor shall request a final project inspection. If the Town of Hayden inspection reveals deficiencies in the project due to poor materials or workmanship of the Contractor, the Contractor shall correct the deficiencies as soon as possible. If the inspection reveals deficiencies that are due to routine wear and tear, snow plowing, the elements, or other factors other than poor workmanship or materials the Contractor shall repair the deficiencies as negotiated with the Town of Hayden. After all deficiencies are corrected the corrected work will be re-inspected.



2. Letter of Final Project Acceptance

Upon issuance of a letter of Final Project Acceptance by the Town of Hayden, the Development Owner and Contractor shall be relieved of all warranty liability except for a one-year warranty of items repaired under the original warranty.

By accepting a contract for performing the work, the Contractor agrees to expedite the acceptance procedure to obtain the Preliminary Acceptance within the Contract time allowed. Inspection by the Town of Hayden after November 1 and before May 1 may be made only by special request and then only if weather conditions permit i.e. snow free ground with above zero temperature and no precipitation.

Inspections will not be made when weather would prohibit a thorough inspection.

Until final acceptance is granted, the work shall remain under warranty and any maintenance and repair work is the responsibility of the Development Owner or Contractor.



Checklist
Town of Hayden Construction Plan and Specification Requirements
January, 2019

The following are the items that must be included in the construction drawings and specifications.

1. General Items shall be included in all plan drawings (as applicable).
 1. Coversheet with vicinity map and contact information on Owner and designer(s)
 2. 24" x 36" drawing format
 3. Conventional scale not greater than 1" = 50
 4. Existing and proposed two (2) foot contours on Town of Hayden Datum. Referenced benchmark.
 5. All existing site fixtures including (but not limited to):
 - a. Structures
 - b. Water, sewer, electric, telephone, gas and cable TV, utility mains
 - c. Ditches and irrigation ditches
 - d. Drainage structures, including electronics
 - e. Easements
 - f. Edge of roadway shoulders, pavement, sidewalks, trails, right-of-ways
 - g. Fences, trees, vegetation, rocks, soils test hole location, wetlands
 6. Property and lot boundaries
 7. Lot and parcel numbers
 8. Legend and construction notes
2. Grading and Drainage
 1. Existing conditions
 2. Proposed two (2) foot contours
 3. Proposed grading slopes
 4. Proposed edge of pavement, edge of gravel, edge of sidewalks and trails.
 5. Proposed drainage channels and associated propose grading contours
 6. Proposed water and sewer utilities (shown in background).
 7. Proposed drainage structures and elevations.
 8. Adequate existing and proposed spot elevation to review and construct work.
 9. Necessary details
3. Roadways
 1. Plan and profile drawings showing all horizontal and vertical geometry.
 2. Roadway centerline grades
 3. Topsoil sections, cross sections
 4. Curve return radii
4. Water Main Plans
 1. Type and size of pipe
 2. Location and description of all appurtenances, that is, valves, bends, tees, fire hydrants, reducers, etc. The location may be reflected as linear feet between appurtenances provided that all linear feet can be referenced to a surface object, or the location may be referenced by stationing.
 3. Fire hydrant numbering
 4. Bench mark and reference datum
 5. Easements (Existing and proposed)
 6. Proposed sewer utility
 7. Sewer crossings



5. Sewer Main Plans

1. Type and size of pipe
2. Bench mark and reference datum
3. Easements (existing and proposed)
4. Proposed water utility
5. Manhole access benches
6. Manhole numbers

6. Sewer Main Profiles

1. Type and size, length and slope of pipe
2. Stationing for all manholes
3. Location for all taps
4. Manhole invert elevations
5. Water main, water service and other utility crossings
6. Existing and proposed gravel surface
7. Other existing features (fences, roads, ditches, etc.)

7. Service Lines or Stubs

1. Location
2. Type of pipe
3. Size of pipe
4. Length of pipe
5. Slope of pipe (sewer only)
6. Location or station for tap
7. Elevation at end of service (sewer only)

8. Additional Documents Required:

1. Landscape plan with water and sewer utilities and easements illustrated
2. Dry utility plan with both dry and water and sewer utilities illustrated
3. Preliminary plat showing easements
4. Details
5. Sediment and erosion control plans
6. Supplemental Specifications, and Special Provisions
7. Water main profiles may be required for water mains outside roadways or where grading occurs over existing mains.



SECTION C ENGINEERING SERVICES

The following is the minimum level of construction engineering services to be provided by a project owner for development work requiring The Town of Hayden acceptance of public improvements including roadway, drainage, sidewalk, trail, water and wastewater facilities. The construction engineering work items listed are intended to be the minimum guidelines to which the owner shall comply. The level of construction engineering services shall be as stated and sufficient to allow the engineer to determine, in general, if the work is proceeding in accordance with the construction documents.

A. QUALIFICATIONS OF PROJECT OBSERVATION PERSONNEL

1. The individual(s) completing construction observation shall be a professional engineer registered in the State of Colorado or a properly trained engineering technician who is under the direct supervision of a professional engineer. The on-site personnel shall be experienced in construction observation of the type of improvement under construction.

B. WATER AND WASTEWATER MAIN INSTALLATION

1. Limits of right of way and easements shall be established prior to staking of mains.
2. Stake centerline of main and location of all appurtenances.
 - a. Manhole invert elevations to be staked with offset hub elevations with cuts and stationing.
3. Pipeline installation observation
 - a. Document all pipeline materials meet approved specifications.
 - b. Observe trench preparation foundation suitability and placement and suitability of bedding and shading materials
 - c. Observe all mechanical joint fittings and thrust blocks prior to backfill.
 - d. Contractor or Engineer shall document as-constructed conditions prior to backfill.
 - e. Some pipelines, at the discretion of Town of Hayden, may require full time construction engineering observation as construction and pipeline installation proceeds.
 - f. Compaction and moisture testing shall be performed on backfill within roadways under sidewalks and trails and outside roadways when settlement is not deemed suitable.
 - h. Document suitability of backfill material.
4. Pipeline Testing
 - a. Observe and document sampling and testing per specifications including; bacteriological, hydrostatic and leakage tests.

C. ROADWAY CONSTRUCTION

1. Roadway subgrade, construction observation and testing
 - a. Document suitability of topsoil stripping limits
 - b. Document suitability of fill materials
 - c. Document or summarize all materials testing
 - d. Compaction and moisture testing shall be performed at sufficient intervals to allow the engineer to meet the statement requirements in this section. Generally testing shall occur



every 100 ft. alternating left, center, right at every 1 ft. vertical or change in material. Document all testing, all failed testing shall be successfully re-tested.

- e. Document preparations of final subgrade surface and proof rolling of final subgrade surface.
- f. Document significant subgrade repairs and any on use geotextile fabrics. The use of geotextile fabrics for subgrade installation requires The Town of Hayden's approval in writing prior to installation.
- g. Document placement of rock fills.

2. Gravel surfacing, observation and testing

- a. Document all materials testing
- b. Surface and thickness testing compaction and moisture testing shall be performed at the frequencies required in those specifications. Document all test results. All failed testing shall be suitably re-tested.

3. Bituminous pavement, observation and testing

- a. Document or summarize all materials testing
- b. Document all quality control testing.

D. CONCRETE PAVING

1. Concrete sidewalks, trails, curb and gutter, observation and testing.

- a. Document or summarize all materials testing.
- b. Observe and document suitability of prepared subgrade prior to concrete placement.
- c. Every truckload of concrete shall be observed for suitability, tested for slump and air entrainment and the amount of field added water recorded. Otherwise, quality control testing requirements shall be per the specifications. Document observations and all quality control testing.
- d. Document curing procedure.

E. SUBMITTALS FOR ACCEPTANCE

1. Water and Wastewater - Record Documents

- a. Prior to preliminary acceptance the engineer shall provide Town of Hayden with draft record documents of all water and sewer infrastructure included in the project.
- b. To maintain the integrity of the Town of Hayden Facility Maps, all surface level appurtenances (e.g., valve boxes, manholes, cleanouts, fire hydrants, PRV's, air release valves, curb stops, sewer stubs, etc) are to be located and surveyed. The N, E, and Z coordinates are to be included on the record documents for these appurtenances.
- c. After initial review of the record documents, Town of Hayden will either approve or return for revisions.
- d. After the blue line review set of record documents have been approved by Town of Hayden provide reproducible mylars, 11x17 ½ size (copy size), and both CAD and PDF files of the record documents.
- e. Minimum criteria to be included in record documents:
 - 1) Bench mark and reference datum.
 - 2) Distance or stations along mainline between valves, fittings, manholes, cleanouts, taps, etc.
 - 3) Position of mainline relative to center-line of roadway, edge of pavement, structures, etc.
 - 4) Enumeration of all fire hydrants and manholes per Town of Hayden numbering system.
 - 5) Location of service line connections to main.
 - 6) 3-point ties on the Drawings (extra detail sheets may be necessary), locating all appurtenances including: valve boxes, manholes (outside of paved



roadways), curb boxes, services stub-outs, vaults, misc. items, etc.

- 7) Manhole invert elevations, manhole stationing, manhole diameters, pipeline material and diameters, wye connections, stub-out elevations.
- 8) Profiles: existing ground, pipeline invert, and manhole lid elevation. (Design information is sufficient if it has not changed substantially).
- 9) Elevation and length of all service lines.
- 10) Any additional items required.

2. Roads – Record Documents

In the event revisions to the road or drainage design occur during construction, provide record documents.

Minimum criteria to include in record documents:

- Revisions to drainage structure locations, size, grades
- Changes to road centerline horizontal alignments greater than one foot.
- Changes to construction details

3. Daily Observation Logs

- a. The engineer shall keep a log of daily site observations. The engineer shall make entries to note any conditions that will be of assistance to Town of Hayden after construction is complete.
- b. Typical entries shall include:
 - 1) As-constructed dimensions
 - 2) Conditions that effect construction requirements or procedures.
 - 3) Alteration of plans, character or work and quantities.
 - 4) Any decisions or interpretation given the contractor.
 - 5). Observations completed and summary of quality control testing.
 - 6). Weather
 - 7) Personnel involved.

4. Construction Report.

- a. The professional engineer(s) responsible for construction observation of the project must submit a construction report that summarizes observation services completed, a stated opinion that the work was completed in general conformance with the approved plans and specifications and a summary of any work that in the engineer's opinion, is not in general conformance with or otherwise varies from the approved plans and specifications, based on the observations made by him/her or the engineering technician performing work under his/her direct supervision.



SECTION 1031
STAKING, QUANTITIES, AND AS-CONSTRUCTED MEASUREMENTS

PART 1 GENERAL

1.1 DESCRIPTION

Work Included: Detailed surveys necessary to construct the work, determine installed quantities for payment, and show the location and extent of installed facilities for the Town of Hayden's permanent record.

1.2 QUALITY ASSURANCE

Staking and surveys shall be completed by persons experienced in construction surveying who are capable of taking accurate measurements, determining when smaller survey tolerances are necessary, and providing neat, legible and accurate field notes or sketches.

The survey tolerances specified herein shall be considered maximums. When necessary the Contractor shall supply more accurate staking to achieve the intended results at critical locations.

1.3 SUBMITTALS

In writing, supply the staking procedures proposed to meet the requirements of this section for the Engineer's review and concurrence. Include a schedule indicating when Owner-supplied survey work for the various work segments is anticipated to be required. Submit this data at, or before, the pre-construction meeting; or, if none is held, at a time mutually agreeable with the Engineer.

PART 2 PRODUCTS

No products this Section.

PART 3 EXECUTION

3.1 GENERAL

A. Notification:

Supply the Engineer with an updated schedule for Owner supplied survey work as schedule changes occur. Provide a reasonable amount of time for the Owner to respond based upon the extent of survey work needed. A minimum notification of 2 days is required. Any delays in the performance of project work which may result from the Contractor's failure to give reasonable notice of the need for Owner supplied survey work shall be the Contractor's sole responsibility.

B. Discrepancies:

Any known or suspected discrepancies found in the field staking when compared to the Drawings, Specifications, other field staking or site conditions shall be immediately reported to the Engineer. Work done by the Contractor after his discovery of such discrepancies shall be done at the Contractor's risk.



C. Construction Staking

1. Owner's Responsibility:

In general, the Owner shall provide overall project control staking. This will typically include base lines, bench marks, and in some instances, location stakes for some facilities.

For new subdivision projects the Owner will provide pins or stakes at all lot corners and other points on the subdivision plat. These lot stakes will be the only horizontal control provided in new subdivisions.

The Owner may provide additional detailed staking when the facility is not specifically dimensioned on the plans and some detailed field design is required.

2. Contractor's Responsibility:

Verify base lines and control points provided by the Owner prior to commencing detailed staking.

Carefully preserve all Owner-supplied bench marks, reference points and stakes. In the case of willful or careless destruction, Owner-supplied staking shall be reset by the Owner and the actual cost of such re-staking shall be deducted from the Contractor's payment.

Complete and carefully preserve all detailed staking which is necessary to install the Work to accurate line and grade. If the Contractor's stakes are destroyed during progress of the work and are deemed necessary by the Engineer to accurately complete the work, the Contractor shall reset such stakes at no additional cost to the Owner. (The Contractor is cautioned not to prematurely destroy horizontal offset and elevation reference stakes.)

Routinely check the work as it progresses to be sure it conforms to the staking.

D. Quantity Surveys:

Pay quantity surveys are divided into three categories and are to be measured and calculated as follows:

1. Items which can be tabulated directly using lineal or area measurements or number count and which can be easily verified at a later date with field measurements. These items are to be field measured by the Contractor and supplied in tabular form with the pay requests. Examples of these items include pipe length, manholes, valves, acreage of re-vegetation, etc.
2. Items which are buried and which cannot be easily verified after the work is complete. The Contractor shall measure these items daily as they are being installed and no less than weekly submit an itemized list of all such quantities with backup data to the Engineer for review. Examples of these items include spot gravel placement, washed rock used for foundation stabilization, etc.
3. Volumetric quantities which require field measurements and detailed drafting and/or other calculation procedures to arrive at the pay quantities. Measurements for these quantities may be made partially by the Contractor and partially by the Owner's Engineer or Surveyor. These measurements will be supplied to the Engineer and the final quantities will be calculated by the Engineer. Examples of these items include earthwork, base and sub-base gravels, etc.



E. As-Constructed Measurements:

The Contractor shall be responsible for measuring all facilities which are to be included on record drawings and which will be buried and cannot be measured at a later date. Where three-point ties are called for, the Contractor shall provide measurements to permanent surface objects which are within 100' of the facility. The angle between three-point tie lines shall be no less than 45 degrees and the measurement shall be to the nearest 0.5'. If no such objects exist the Contractor shall make alternate measurement plans which shall be approved by the Engineer.

The Engineer shall supply 8 1/2" by 11" forms to the Contractor to be used for keeping the as-constructed measurements. The Contractor shall keep all measurements on these standard forms in a neat and legible manner and assure that the measurements are accurate.

3.2 STAKING, QUANTITIES, AND AS-CONSTRUCTED MEASUREMENTS

A. Sanitary and Storm Sewer Collection Systems:

1. Contractor's Responsibility:

Location stakes for all facilities which are specifically dimensioned on the plans.

Horizontal offset and elevation reference stakes as needed.

Provide grade control methods to assure lines are being installed at the grades required and/or with the proper cover.

Assure that manhole rims, inlet rims, cleanouts, and any other facilities are set to the proper elevation relative to the final surface grade.

Assure that service lines terminate at the locations specified in the plans and specifications in relation to the street right of way or other criteria specified.

2. Survey Tolerance:

Horizontal = 0.5'; Vertical = 0.03'.

3. Quantities:

Provide quantity information in tabular form with each pay request to include:

- a. Manhole to manhole distances for mains.
- b. Service line lengths by lot or house number.
- c. Manhole depths tabulated by manhole number.
- d. Similar tabulations for other facilities.

5. As-Constructed Measurements:

Provide the following:

- a. The distance along the main from the downstream manhole to each wye.
- b. The length of each service line from the main to the end of the service line.



- c. The distance from the main to each bend in a service line.
- d. Two additional ties to the end of each service line and to each bend in a service line.
- e. The approximate depth (± 0.2 feet from final grade) of the end of each service line. When grade is critical provide the invert elevation of the end of the service line.
- f. Measurements of any special construction details such as connections to existing lines, concrete encasements, groundwater drains and dams, vertical clearances with other pipelines or utilities, etc.

B. Water Distribution Systems:

1. Contractor's Responsibility:

Location stakes for all facilities which are specifically dimensioned on the plans.

Horizontal offset and elevation reference stakes for all facilities.

Provide grade control to assure that the lines are installed at the proper cover.

Assure that hydrants, valve boxes, and other appurtenances are at the proper elevation relative to the final surface grade.

Assure that service lines terminate at the locations specified in the plans and specifications in relation to the street right of way or other criteria specified.

2. Survey Tolerance:

Horizontal = 0.5'; Vertical = 0.2'.

3. Quantities:

Provide quantity information in tabular form with each pay request to include:

- a. Main line distances from fitting to fitting.
- b. Service line lengths by lot or house number.
- c. Hydrant lateral lengths by hydrant number.
- d. Similar tabulations for other facilities.

4. As-constructed Measurements:

Provide the following:

- a. The dimensions specified in the Quantities section above.
- b. Three point ties to all buried fittings and other buried facilities which cannot easily be located at a later date. Three point ties can be to other water system surface features such as valves and hydrants.
- c. Measurements from fitting to fitting in areas of complicated connections.
- d. Measurements for water line cover depths when depths are less than 7' or greater than 8'.



C. Roads:

1. Contractor's Responsibility:

Centerline staking, to include a permanent centerline offset reference hub on one side at least 10' outside the construction limits, and slope stakes on both sides of the road. Additional centerline, slope, and offset staking will be required at PC's and PT's of curves.

"Bluetop" stakes for subgrade, base course, and subbase course including a stake at centerline, both shoulder points, and at any other cross section grade break. Additional blue top staking will be required at superelevation transition points.

A stringline for asphalt placement layed out from centerline, or if centerline is not dimensioned on the plans, layed out to "best fit" the existing road surface. (The Engineer's approval is required prior to asphalt placement.)

Location and grade stakes for all other facilities when specifically dimensioned on the plans.

Radius points for all intersections.

Routine checks of slopes and subgrade as the work progresses to assure that the proper lines and grades are being achieved.

Unless otherwise specified all staking shall be at 50' intervals. When additional centerline, slope, and offset staking is required at PC's and PT's of curves, and additional blue top staking is required at superelevation transition points the 50' station can be omitted provided that the additional points are within 15' of the 50' station.

2. Survey Tolerance: Tolerances shall be per the following table:

<u>Staking Item</u>	<u>Horizontal</u> (Relative to centerline)		<u>Vertical</u>
	<u>Parallel</u>	<u>Perpendicular</u>	
Benchmarks	n/a	n/a	0.02'
PI's	0.1'	0.1'	n/a
Centerline	0.1'	0.1'	n/a
Offset Reference			
For PC's & PT's	0.1'	0.1'	0.02'
For all others	0.5'	0.1'	0.02'
Slope Stakes	0.5'	0.2'	0.20'
Bluetops	0.5'	0.2'	0.03'
Drainage Structures	1.0'	1.0'	0.10'
Asphalt Stringline	n/a	0.2'	n/a

Note: The horizontal tolerances for offsets, slope stakes, and blue tops require the use of a right angle prism or similar device.



3. Quantities:

Provide quantity information in tabular form with each pay request to include:

- a. Culvert pipe by station location.
- b. Gravel from station to station.
- c. Asphalt from station to station.
- d. Fencing, special ditches, unsuitable excavation and replacement, fabric, etc.

The Engineer will determine earthwork quantities with assistance from the Contractor. The Contractor shall provide the field elevation of the centerline and slope stake points as well as any other cross section information required.

The Engineer will measure the topsoil stripped by measuring the topsoil depths at the centerline and slope catch points or other appropriate points on the cross section.

Rock excavation will be measured by the Contractor by use of cross sections or other method approved by the Engineer. This cross section data will be supplied to the Engineer for calculation of the rock quantity.

4. As-constructed Measurements: Generally none required.

D. Overlot Grading, Embankments, and Other Earthwork:

1. Contractor's Responsibility:

Detailed grade staking using a grid system supplemented with slope stakes at the grading limits. The method of establishing the grid shall be approved by the engineer prior to the start of the work. The size of the grid increments shall be sufficiently small to allow accurate grading of the areas in between grid points. As grading progresses the grid staking will likely need to be reset one or more times so that the final grades can be verified as accurate. In some cases blue top stakes may be required, particularly if the final surface is to receive a gravel surfacing.

2. Survey Tolerances:

Survey tolerances will vary depending on the nature of the overlot grading. Generally the tolerances shall be similar to those specified in the previous Road section.

3. Quantities:

Quantities will be calculated by the Engineer with field measurement data supplied by the Contractor similar to that specified for Roads in the previous section. Field information required from the Contractor will include the elevations of the existing ground at the grid and slope stake points, and any final grade information if such final grade varies from the plans.

4. As-constructed Measurements: Generally none required.

E. Structures:

1. Contractor's Responsibility:

Detailed staking required to assure the structure is constructed to the lines and grades specified.



2. Survey Tolerances:

The Contractor shall consult with the Engineer on the tolerances required.

3. Quantities:

Generally no unit price items to measure. Provide all measurements of any unit price earthwork associated with the structure.

4. As-constructed Measurements:

Provide as constructed measurements for all portions of the structure not constructed in accordance with the dimensions on the plans or as shown on the approved shop drawings.

Provide measurements of all utility or other lines which pass under or near structures. Provide details of any modifications made to reinforcement.

F. Curb, Gutter, Sidewalk, and Paving Stones:

1. Contractor's Responsibility:

When part of a road project or specifically dimensioned on the plans, the Contractor shall provide line and grade staking at 25' or 50' stations as deemed appropriate. When line and grade staking is provided by the Owner, the Contractor shall supplement the Owner supplied staking with additional line and grade stakes as required, including slope stakes where necessary. The Contractor shall also provide any stringline or batterboard staking desired.

2. Survey Tolerances: Tolerances shall be per the following table:

<u>Staking Item</u>	<u>Horizontal</u>	<u>Vertical</u>
Curb, Gutter & Sidewalk Adjacent To Roads Or Other Fixed Facilities.	0.05'	0.02'
Meandering Sidewalks	0.5'	0.20'

3. Quantities:

Provide lineal or area quantity tabulations of completed work with each pay request.

4. As-constructed Measurements: Generally none required.

G. Bicycle and Pedestrian Paths:

1. Owner's Responsibility:

When not part of and adjacent to a road project or not specifically dimensioned on the plans, centerline staking at the ends of all straight sections, at all radius points and at changes in cross section or width. At the Owner's option grade staking may also be provided.

For projects which are specifically dimensioned on the plans, only a base line and bench mark will be provided.

When part of a road project and the road centerline controls the line and grade, no additional staking will be provided by the Owner beyond that provided for the road.



2. Contractor's Responsibility:

When part of a road project or specifically dimensioned on the plans, line and grade staking at 25' or 50' stations as deemed appropriate. When separate staking is provided by the Owner, offset stakes for all Owner-supplied centerline stakes, and slope stakes where necessary.

3. Survey Tolerances:

Horizontal = 0.5'; Vertical = 0.2'.

4. Quantities:

Provide lineal or a real quantity tabulations of completed work with each pay request. Slope stake notes and other measurements taken to establish earthwork quantities shall also be submitted.

H. Miscellaneous:

Other facilities not specifically addressed in this section shall be completed in a fashion similar to that specified herein for similar facilities. The Contractor, Owner, and the Engineer shall agree on the staking, quantity survey, and as constructed measurement requirements prior to beginning the project.

PART 4 MEASUREMENT AND PAYMENT

Separate payment for staking, including quantity surveys related to the staking, will be made on a lump sum basis when a bid item for this work is provided in the bid form.

If no bid item is provided, the cost of staking shall be included in the work item price of the facility being staked.

No separate payment will be made for other quantity surveys or for as-constructed measurements.

Pay requests submitted without required quantity survey information and as-constructed measurements shall be considered incomplete. The Engineer will notify the Contractor of any such deficiencies and shall give the Contractor one week to supply the required information. If the information is not supplied promptly, the Engineer will process the pay request and the Owner will withhold an additional 20% from all pay items for which information is missing or is not in correct form. The additional withheld payment will not be made until the next regular pay request after the information is received in correct form.



SECTION 1070 CUTTING AND PATCHING

PART 1 GENERAL

1.1 DESCRIPTION

Work included: This section establishes general requirements for excavation, cutting, fitting, and patching necessary to:

Make the individual project components fit and function properly as a complete installation.

Remove and replace work or components not conforming to the requirements of the Specifications.

Uncover ill-timed, unsupervised, or untested work for inspection and, or testing.

1.2 QUALITY ASSURANCE

Follow the requirements of the Specifications, the manufacturer's recommendations, and, when necessary, the Engineer's instructions to assure the completed work meets the intent of the Specifications and the work components are not damaged while proceeding.

1.3 SUBMITTALS

- A. Prior to proceeding with cutting and patching which the Contractor believes is beyond the original scope of work, the Contractor shall submit a clarification request outlining the basis for his assertion to include a cost estimate for any additional charges. The Engineer's approval is required before proceeding.
- B. Submit on any proposed cutting and patching that is not specifically required and addressed by the Specifications. Do not proceed without the Engineer's authorization.
- C. Submit on any proposed cutting and patching which affects structural integrity. Do not proceed without the Engineer's authorization.
- D. Submit on any proposed cutting and patching which will alter or affect work performed by others under separate contract with the Owner. Do not proceed without the Engineer's authorization.

PART 2 PRODUCTS

No products this Section.

PART 3 EXECUTION

3.1 PREPARATION

- A. Inspection: Inspect existing conditions to determine components subject to movement or damage during cutting, excavating, backfilling, and patching. After exposing the work, determine conditions which affect the method of installation.
- B. Discrepancies: Immediately notify the Engineer if exposed conditions are not as anticipated or as shown on the Drawings. Do not proceed until all discrepancies affecting the segment of work being completed have been resolved.



3.2 PERFORMANCE

Provide all required protection including, but not limited to dewatering, shoring, bracing, and support to maintain structural integrity of new and existing structures, utilities, as well as all other affected components or materials.

Perform all required excavating and backfilling as required under the appropriate sections of the Contract Documents.

Perform cutting and demolition by methods which will prevent damage to other portions of the work and will provide proper surfaces to receive installation or repair of new work.

Perform fitting and adjustment of products to provide a finished installation complying with the specified tolerances and finishes, and the requirements of the manufacturer of the products.

PART 4 MEASUREMENT AND PAYMENT

No separate measurement for payment will be made for the Work under this section. Its cost shall be considered incidental to the project.



SECTION 1085 APPLICABLE STANDARDS

PART 1 GENERAL

1.1 DESCRIPTION

Work included: Throughout the Contract Documents, reference is made to codes and standards which establish qualities and types of workmanship and materials, and which establish methods for testing and reporting on the pertinent characteristics.

Where materials or workmanship are required by these Contract Documents to meet or exceed the specifically named code or standard, it is the Contractor's responsibility to provide materials and workmanship which meet or exceed the specifically named code or standard.

It is also the contractor's responsibility, when so required by the Contract Documents or by written request from the Engineer, to deliver to the Engineer all required proof that the materials or workmanship, or both, meet or exceed the requirements of the specifically named code or standard. Such proof shall be in the form requested in writing by the Engineer, and generally will be required to be copies of a certified report of tests conducted by a testing agency approved for that purpose by the Engineer.

1.2 QUALITY ASSURANCE

- A. Familiarity with pertinent codes and standards: In procuring all items used in this work, it is the Contractor's responsibility to verify the detailed requirements of the specifically named codes and standards and to verify that the items procured for use in this work meet or exceed the specified requirements.
- B. Rejection of non-complying items: The Engineer reserves the right to reject items incorporated into the work which fail to meet the specified minimum requirements. The Engineer further reserves the right, and without prejudice to other recourse the Engineer may take, to accept non-complying items subject to an adjustment in the Contract Amount as approved by the Engineer and the Owner.
- C. Applicable standards listed in these Specifications include, but are not necessarily limited to, standards promulgated by the following agencies and organizations:
 - 1. AASHTO = American Association of State Highway and Transportation Officials, 444 North Capital Street, NW, Suite 249 Washington, DC 20001.
 - 2. ACI = American Concrete Institute, Box 19150, Redford Station, Detroit, Michigan 48219.
 - 3. AISC = American Institute of Steel Construction, Inc., 1221 Avenue of the Americas, New York, New York 10020.
 - 4. ANSI = American National Standards Institute (successor to USASI and ASA) 1430 Broadway, New York, New York 10018.
 - 5. ASTM = American Society for Testing and Materials, 1916 Race Street, Philadelphia, Pennsylvania 19103.
 - 6. AWS = American Welding Society, Inc., 2501 N. W. 7th Street, Miami, Florida 33125.
 - 7. AWWA = American Water Works Association, Inc., 6666 West Quincy Avenue, Denver, Colorado 80235.



8. CDOT (Formerly CDOH) = Colorado Department of Transportation, 2829 W. Howard Pl. Denver, CO 80204, reference: "Standard Specifications for Road and Bridge Construction".
9. CRSI = Concrete Reinforcing Steel Institute, 228 North LaSalle Street, Chicago, Illinois 60610.
10. CS = Commercial Standard of NBS, U.S. Department of Commerce, Government Printing Office, Washington, D.C. 20402.
11. FGMA = Flat Glass Marketing Association, 3310 Harrison, Topeka, Kansas 66611.
12. NAAMM = The National Association of Architectural Metal Manufacturers, 1033 South Boulevard, Oak Park, Illinois 60302.
13. NEC = National Electrical Code (see NFPA).
14. NEMA = National Electrical Manufacturers Association, 155 East 44th Street, New York, New York 10017.
15. NFPA = National Fire Protection Association, 470 Atlantic Avenue, Boston, Massachusetts 02210.
16. NSF = NSF International, 3475 Plymouth Road, PO Box 0140, Ann Arbor, Michigan 48113-0140.
17. SDI = Steel Deck Institute, 135 Addison Avenue, Elmhurst, Illinois 60125
18. SSPC = Steel Structures Painting Council, 4400 5th Avenue, Pittsburgh, Pennsylvania 15213.
19. TCA = Tile Council of America, Inc., P.O. Box 326, Princeton, New Jersey 08540.
20. Underwriters' Laboratories, Inc., 207 East Ohio Street, Chicago, Illinois 60611.
21. Fed Specs and Fed Standards Specifications Sales (3FRI), Bldg, 197, Washington Navy Yard, General Services Administration, Washington, D.C. 20407.
22. MIL-SPECS Military Specifications, Superintendent of Documents, U.S. Government Printing Office, Washington D.C. 20402.
23. UBC = Uniform Building Code, International Conference of Building Officials, 5360 South Workman Mill Road, Whittier, California 90601.

PART 2 PRODUCTS

No products this Section.

PART 3 EXECUTION

The Contractor is responsible for being familiar with all named or implied codes. The latest revision or edition of codes or standards shall be used.

PART 4 MEASUREMENT AND PAYMENT

No separate measurement for payment will be made for the Work under this section. Its cost shall be considered incidental to the project.



SECTION 1300 SUBMITTALS AND SUBSTITUTIONS

PART 1 GENERAL

1.1 DESCRIPTION

A. Work included:

Preparation and submittal of shop drawings, cut sheets, certifications of compliance or other documents or samples as required by the Contract Documents in order to ensure that the specified products are furnished and installed in accordance with design intent.

B. Additional requirements are described in the following sections of the Contract Documents:

1. Additional Supplemental General Conditions

SCHEDULES, REPORTS, AND RECORDS section; SHOP DRAWINGS section;
SUBSTITUTIONS section.

2. General Conditions

Section 3. SCHEDULES, REPORTS AND RECORDS

Section 8. SUBSTITUTIONS

3. Specifications

Individual requirements for submittals and substitutions may also be described in the technical Specifications section pertaining to the item.

1.2 QUALITY ASSURANCE

The Work is based on the standards of quality established in the Contract Documents.

All products proposed for use, including those specified by required attributes and performance, shall require review by the Engineer before being incorporated into the Work.

The Contractor shall bear ultimate responsibility for providing a complete working system and shall guarantee that all installed system components are compatible and will provide for the intended operation of the component and the system of which it is a part.

PART 2 PRODUCTS

2.1 SUBMITTAL SCHEDULE

- A. General: At the Pre-Construction Conference or within 10 days after Notice of Award, whichever comes first, compile and submit 2 copies of a complete and comprehensive schedule of all submittals anticipated to be made during progress of the work. Include a list of each type of item for which Contractor's drawings, Shop Drawings, Certificates of Compliance, material samples, guarantees, or other types of submittals are required. Upon approval by the Engineer this schedule will become part of the Contract and the Contractor will be required to adhere to the schedule except when specifically permitted otherwise.



- B. Coordination: Coordinate the schedule with all necessary subcontractors and materials suppliers to ensure their understanding of the importance of adhering to the approved schedule and their ability to so adhere. Coordinate as required to ensure the grouping of submittals as described in Paragraph 3.2 below.
- C. Revisions: Revise and update the schedule on a monthly basis as necessary to reflect conditions and sequences. Promptly submit revised schedules to the Engineer for review and comment.

2.2 SHOP DRAWINGS AND COORDINATION DRAWINGS

Shop Drawings:

- A. Scale and measurements: Make all Shop Drawings accurately to a scale sufficiently large to show all pertinent aspects of the item and its method of connection to the work.
- B. Prints required: Submit 4 hard copies of all Shop Drawings or a single electronic copy.
- C. Shop Drawings shall not be made on copies of the Contract Documents.

2.3 MANUFACTURERS' LITERATURE

Submit 4 copies of manufacturer's literature. When the submitted literature includes options or other data not pertinent to the work, clearly indicate which items and options are being supplied.

2.4 SAMPLES

- A. Accuracy of Samples: Samples shall be of the precise article proposed to be furnished.
- B. Number of Samples required: Unless otherwise specified, submit 2 samples one of which will be retained by the Engineer.
- C. Use of Engineer's Sample: The Contractor may submit a clarification request requesting that the Engineer's retained sample be installed in the project. The Engineer may approve the request if, in his sole opinion, it is not critical that the sample be retained.

2.5 COLORS AND PATTERNS

Unless the precise color and pattern is specifically described in the Contract Documents, and whenever a choice of color or pattern is available in a specified product, submit accurate color and pattern charts to the Engineer for review and selection.

2.6 SUBSTITUTIONS

Submittals for proposed substitutions shall meet the requirements of this section.

2.7 AVAILABILITY OF SPECIFIED ITEMS

- A. Verification: The Contractor shall be responsible for verifying to his satisfaction that all specified items will be available in time to allow orderly and timely progress of the Work.
- B. Notification: In the event specified items will not be available, the Contractor shall notify the Engineer prior to receipt of bids.
- C. Delays: The costs of delays resulting from non-availability of specified items, when such delays could have been avoided by the Contractor, will be the Contractor's liability and shall not be borne by the Owner.



PART 3 EXECUTION

3.1 IDENTIFICATION OF SUBMITTALS

- A. General: Consecutively number all submittals. Accompany each submittal with a letter of transmittal containing all pertinent information required for identification and checking of submittals.
- B. Internal Identification: On each copy of each submittal, and elsewhere as required for positive identification, clearly indicate the submittal number in which the item was included.
- C. Resubmittals: When material is resubmitted for any reason, transmit under a new letter of transmittal.
- D. Submittal Log: Maintain an accurate submittal log for the duration of the Contract, showing current status of all submittals at all times. Make the submittal log available for the Engineer's review upon request.

3.2 COORDINATION OF SUBMITTALS

- A. General: Prior to submittal for approval, use all means necessary to fully coordinate all material including, but not necessarily limited to:
 - 1. Determine and verify all interface conditions, catalog numbers, and similar data.
 - 2. Coordinate with other trades as required.
 - 3. Clearly indicate all deviations from requirements of the Contract Documents.
- B. Grouping of Submittals: Unless otherwise specified, make all submittals in groups containing all associated items to ensure that information is available for checking each item when it is received. Partial submittals may be rejected as not complying with the provisions of the Contract Documents and the Contractor shall be strictly liable for all delays so occasioned.

3.3 TIMING OF SUBMITTALS

- A. General: Make all submittals far enough in advance of schedule dates for installation to provide all time required for reviews, for securing necessary approvals, for possible revisions and resubmittals, and for placing orders and securing delivery.
- B. Engineer's Review Time: In scheduling, allow at least 10 calendar days for review by the Engineer following his receipt of the submittal.
- C. Delays: Delays caused by tardiness in receipt of submittals will not be an acceptable basis for extension of the Contract completion date.



3.4 ENGINEER'S REVIEW

- A. General: Review by the Engineer shall not be construed as a complete check, but only that the general method of construction and detailing is satisfactory. Review shall not relieve the Contractor from responsibility for errors which may exist.
- B. Authority to Proceed: The notations "No Exception Taken", "Make Corrections Noted", and "Other", authorize the Contractor to proceed with fabrication, purchase, or both, of the items so noted, subject to the revisions, if any, required by the Engineer's review comments.
- C. Revisions: Make all revisions required by the Engineer. If the Contractor considers any required revision to be a change, he shall so notify the Engineer as provided for under "Changes" in the General Conditions. Show each drawing revision by number, date, and subject in a revision block on the drawing. Make only those revisions directed or approved by the Engineer.
- D. Revisions after Approval: When a submittal has been reviewed by the Engineer, resubmittal for substitution of materials or equipment will not be considered unless accompanied by an acceptable explanation as to why the substitution is necessary.

PART 4 MEASUREMENT AND PAYMENT

No separate measurement for payment will be made for the Work under this section. Its cost shall be considered incidental to the project.



SECTION 1410
TESTING LABORATORY SERVICES

PART 1 GENERAL

1.1 DESCRIPTION

Work Included: Sampling and testing soils and aggregates for the work covered in the following sections of these specifications:

- A. Road Subgrade Construction
- B. Gravel Surfacing
- C. Trenching Bedding and Backfill
- D. Bituminous Pavements
- E. Pavement Removal and Replacement

1.2 QUALITY ASSURANCE

- A. General Standards: Testing and sampling shall be done in conformance with the appropriate ASTM or AASHTO standards referenced, or necessary, to establish the quality of the materials and to provide quality control during their installation.
- B. Independent Laboratory: All sampling and testing shall be done by an independent testing laboratory commercially providing the required services to the general public.
- C. Experience: The laboratories shall be experienced in the type of sampling and testing to be completed. All work shall be done by qualified individuals. Where it is industry practice to license or certify individuals to do certain tests, the individuals shall be so licensed or certified.

1.3 SUBMITTALS

- A. General: Submittals shall comply with Section 1300.
- B. Experience Verification: Unless waived by the Engineer, submit the name and qualifications of the independent testing laboratory and individuals to do the work for review prior to proceeding with any testing. The Owner reserves the right to reject the use of a laboratory it deems not qualified to do the sampling and testing.
- C. Quality Control Plan: Submit a written quality control plan to the Engineer for review and acceptability prior to proceeding with any testing.

PART 2 PRODUCTS

There are no products in this section.



PART 3 EXECUTION

3.1 GENERAL

- A. The tests and certifications to be completed by the Contractor shall be as required in the Section pertaining to the work being tested.
- B. A legible handwritten copy of all test data shall be given to the Engineer daily. A typed report on an approved format shall be given to the Engineer on a weekly basis and shall include an analysis of all results showing ranges, averages, and action taken on all failing tests.

3.2 FIELD QUALITY CONTROL

- A. Quality Control Plan: The Contractor shall develop a quality control plan which shall include as a minimum:
 - 1. The assignment of quality control responsibility to specifically named individuals.
 - 2. Performance of regularly scheduled inspection procedures.
 - 3. Provisions for the prompt implementation of control and corrective measures.
 - 4. Provisions for liaison with the Engineer at all times.
 - 5. A listing of all tests required by the contract specifications, including the type and frequency of tests to be taken, the method of sampling, the applicable test standard, and the acceptance criteria or tolerance permitted for each type of test.

PART 4 MEASUREMENT AND PAYMENT

There shall be no separate measurement or payment for the work covered in this section. Its cost shall be considered incidental to the work.



SECTION 1500
TEMPORARY FACILITIES AND CONTROLS

PART 1 GENERAL

1.1 DESCRIPTION

A. Work in this section includes temporary:

1. Utilities.
2. Field offices.
3. Protective enclosures.
4. Sanitary facilities.
5. Fencing and barricading.
6. Access and haul roads.
7. Other temporary facilities as necessary to complete the work.

B. The ladders, planks, hoists, scaffolds, and similar items normally furnished by individual trades in execution of their work is not a part of this section.

1.2 SUBMITTALS

The location, method and extent of providing temporary facilities shall be submitted to the Engineer for review and authorization prior to proceeding.

PART 2 PRODUCTS

2.1 UTILITIES

- A. Water: Furnish and install all water lines and appurtenances necessary for temporary water supply.
- B. Electricity: Furnish and install all equipment and wiring necessary for temporary power.
- C. Heat: Furnish and install all facilities necessary for temporary heat.
- D. Telephone: Furnish and install all facilities necessary for telephone service to any required field offices.

2.2 FIELD OFFICES

- A. Contractor's field office: When called for in the Special Provisions the Contractor shall provide a field office for conducting Contractor's operations to include a separate enclosed space adequate for holding weekly project meetings. Furnish with all required tables, chairs, and utilities.

If a contractor's field office is not specifically required in the Special Provisions, Contractor may provide a contractor's field office subject to the Engineer's review and authorization.



- B. Engineer's field office: If called for in the Special Provisions, provide a field office for the private use of the Engineer and his representatives. The office shall be equipped with three desks and chairs, light, heat and private telephone service. The minimum usable floor space shall be 200 square feet. Two of the three desks will be used for drafting, and shall have minimum top dimensions of 3'-0" x 5'-0".

2.3 PROTECTIVE ENCLOSURES

Supply all trailers, sheds, tarpaulins, canopies, etc., necessary to protect materials and the work.

2.4 SANITARY FACILITIES:

Provide temporary sanitary facilities in the quantity required for the number of personnel working on the project.

2.5 FENCING AND BARRICADING

Provide all fencing and barricading necessary to protect the general public, and to screen the site in accordance with all regulations having jurisdiction over the work.

2.6 ACCESS AND HAUL ROADS:

Provide and maintain all necessary access and haul roads to the work in strict accordance with all regulations governing the Contractor's operations.

2.7 OTHER TEMPORARY FACILITIES:

Provide all other temporary facilities such as signs, steps, bridges, platforms, scaffolds, etc., as necessary to complete the work.

PART 3 EXECUTION

INSTALLATION, MAINTENANCE AND REMOVAL

Contractor shall coordinate with the appropriate utility companies and agencies to make arrangements for temporary service and access.

Make all connections to existing utility systems with minimum disruption to service. When disruption of existing service is required, do not proceed without the Engineer's authorization and, when required, provide alternate temporary service.

Locate electrical distribution boxes such that individual trades' extension cords for power and lighting are limited to 100' maximum length and so that lighting is available to assist the engineer in observing the work.

Maintain all temporary facilities and controls in proper and safe condition as long as needed for completion of the work. Remove all such temporary facilities and controls as rapidly as progress of the work will permit.

All temporary facilities and controls shall remain the property of the Contractor and shall be directly under his control.



PART 4 MEASUREMENT AND PAYMENT

No separate payment will be made for the work under this Section. Its cost shall be considered incidental to the Project.

Contractor shall pay all usage and permit fees required for temporary service and facilities with the exception of long-distance telephone charges incurred by the Engineer in the Contractor supplied Engineer's field office.



SECTION 1562 DUST CONTROL

PART 1 GENERAL

1.1 DESCRIPTION

- A. Work included: The work under this section shall include all equipment, labor, and materials necessary to control dust relating to or resulting from performance of the project work.
- B. Related work described elsewhere: In addition to the requirements described herein, comply with specific requirements for dust control as may be detailed in other Sections of these specifications or as noted on the Drawings.

1.2 QUALITY ASSURANCE

- A. Standards: Comply with all pertinent requirements of Federal, State, or Local agencies which may have jurisdiction over dust control procedures and additives used to aid in dust abatement.
- B. Inspection: The Engineer, Contractor, and Owner shall periodically review the adequacy of dust control efforts and procedures to assure they are satisfactorily meeting the needs of the project.

1.3 SUBMITTALS

- A. Dust control procedure: Prior to commencing the project work the Contractor shall meet with the Owner and Engineer to review his proposed dust control plan and methods to assure their compliance with the specific needs of the project.
- B. Additives: All additives proposed for use as an aid in dust control other than those specified in Section 2.2 shall be reviewed with the Engineer prior to their application. Manufacturers' literature along with recommended application rates shall be provided.

PART 2 PRODUCTS

2.1 WATER

Water used for dust control shall be nonpolluted.

2.2 CHEMICAL ADDITIVES

Calcium Chloride: Shall conform to the requirements of AASHTO M 144 (ASTM-D-98) except that either pellet or flake form shall be acceptable.

PART 3 EXECUTION

3.1 GENERAL

During the performance of the work required by these specifications or any operations appurtenant thereto, the Contractor shall furnish all labor, equipment, materials and means required, and shall carry out proper and efficient measures wherever and as often as necessary to reduce the dust nuisance, and to prevent dust which has originated from his operations from damaging crops, dwellings, or causing a nuisance to persons.



3.2 WATER

- A. Procurement: The Contractor shall be responsible for arranging for the necessary supply of suitable water for dust abatement.
- B. Application: The Contractor shall apply water and/or water with additives on all access and haul roads, excavations, surfaces of refilled trenches, stockpiles, waste areas and other work areas as may be necessary to adequately control dust.
- C. Quantity: The quantity of water required for adequate dust control is variable and depends on climatic factors, soil types, and potential for nuisance. Dust control requirements shall be discussed, established, and reviewed periodically during the course of project work.

3.3 WORK AREAS

The Contractor shall make a reasonable effort to keep work areas and adjacent areas free of excessive dirt and mud which may unnecessarily contribute to a dust nuisance.

Pavement or concrete surfaces adjoining pipe trenches shall be kept broomed off and washed clean of excess excavated material.

PART 4 MEASUREMENT AND PAYMENT

Payment for all costs of equipment and materials required to provide dust control shall be made on a lump sum basis per the Dust Control Bid item. A percentage of the total bid amount will be paid as work progresses proportionate to the dust control effort provided for the pay period.

If no separate bid item is provided, no separate payment will be made for the work under this section. Its cost shall be considered incidental to the Project.



SECTION 1567
EROSION AND SEDIMENT CONTROL

PART 1 GENERAL

1.1 DESCRIPTION

- A. Work included: The work under this section shall include various temporary and permanent measures to control accelerated soil erosion and sedimentation due to construction activities, during construction and until final project acceptance.
- B. The materials and methods described herein shall not be considered as a complete listing of the means for complying with the requirements of this section. Refer also to publications, including references, listed below for additional information.

1.2 QUALITY ASSURANCE

- A. The Contractor shall prepare and apply for a Stormwater Discharge Construction General Permit on projects involving disturbed areas greater than 1 acre, whether singular or part of a phased project, as required by the Colorado Department of Public Health and Environment, Water Quality Division.
- B. Booklet entitled "Erosion and Sediment Control During Construction", Routt County, Colorado
- C. CDOT "Erosion Control and Stormwater Quality Guide", 2002 (Revised Chapter 5 EC 5 & 6 July 2014), or most current edition and other publications as referenced.
- D. Stormwater Management Plan, as prepared for work in Routt County.
- E. Construction Site Management Plan, as prepared for work within the Town of Hayden.

1.3 SUBMITTALS

- A. General:
 - 1. Prior to commencing construction, the Contractor shall prepare, submit and obtain approvals for, a written plan for temporary and permanent Storm Water Management, as may be required by jurisdictional agencies and/or local, county or state governments.
- B. Products:
 - 1. Silt Fence
 - 2. Erosion Control Blanket
 - 3. Erosion Log
 - 4. Turf Reinforcement Mat (TRM)
 - 5. Jute Netting
 - 6. Drain Rock
 - 7. Other products to be used for temporary or permanent controls



PART 2 PRODUCTS

2.1 SILT FENCE

Temporary silt fence shall be composed of: Mirafi 100X filter cloth; with 2" hardwood posts at 10 ft. on center. The filter cloth shall be attached to 6 X 6- 14-gauge wire fabric backing. Pre-fabricated assemblies, such as "Envirofence" as manufactured by MIRAFLI, Inc., with 100X fabric, 1-1/4" hardwood posts, top tensioning belt, 8.3 ft. post spacing and additional plastic net or fabric backing, will be considered for review as or- equal products. Additional silt fence reinforcing may be required and shall be installed as indicated on the Detail Drawings or specified to supplement the standard product.

2.2 HAY BALES

Hay bales shall be certified weed free, bound with color coded twine or wire indicating weed free.

2.3 EROSION CONTROL BLANKET

Erosion Control Blankets shall be straw, with a top and bottom layer of biodegradable netting, Greenfix America WS072B, North American Green S150BN, or reviewed equal.

2.4 EROSION LOG

Erosion logs shall be Strawlogs as manufactured by Greenfix America, Earth Saver or reviewed equal. Logs shall be 9" diameter unless shown otherwise on the drawings.

2.8 TURF REINFORCEMENT MAT

Turf reinforcement mats shall be North American Green C350, or reviewed equal.

2.6 JUTE NETTING

- A. Jute netting shall consist of heavy just mesh of a uniform open plain weave of unbleached yarn with 1 inch by 1-inch spacings. The yarn shall be of a loosely twisted construction having an average twist of not less than 1.6 turns per inch and shall not vary in thickness by more than one-half its normal diameter. The weight of cloth shall average 1.22 pounds per linear yard with a tolerance of +/- 5 percent.
- B. Pins and Staples: Pins or staples shall be made of wire .091 inch or larger in diameter. "U" shaped staples shall have legs 6" long and 1" crown. "T" shaped pins shall have a minimum length of 8 inches after bending. The bar of the "T" shall be at least 4 inches long with the single wire end bent downward approximately 3/4".

2.7 DRAIN ROCK

Shall be 3/4"-1/1/2" clean, free draining rock.

2.8 SEED, MULCH, TACKIFIER, BONDED FIBER MATRIX

Seed, mulch, tackifier and bonded fiber matrix shall be in accordance with the requirements of Section 2821, Revegetation. Mulch, tackifier and bonded fiber matrix may be specified and used separately from seeding.



PART 3 EXECUTION

3.1 GENERAL

All construction activities shall proceed in such a manner so as not to cause or threaten to cause pollution, contamination or degradation of Waters of the State, including, but not limited to any seasonal or permanent watercourse, water body, wetlands, any adjacent property or any other lands required by jurisdictional agencies. The Contractor shall be responsible for minimizing erosion and controlling sediment on site. The Contractor shall install measures as early as practical in the project. If the controls in place are not successful, the Contractor shall provide additional control measures, whether shown on the drawings or not, as necessary to achieve the specified requirements.

The Erosion and Sediment Controls specifically shown or specified are considered to be the minimum recommended for construction of the project. Additional controls will be necessary, depending upon construction sequencing, phasing and the Contractor's methods. The Contractor shall use a mixture of both erosion controls, which protect soils for being displaced, and sediment controls, which stop the transport of displaced soil particles, to satisfy permitting requirements. There shall be a redundancy of controls incorporated into the project and not just a single line of defense.

Areas to be protected may include: slopes of stockpiled and excavated materials; cuts and fills; water bodies, drainages, wetlands, etc.; constructed drainage channels, roadside ditches, culvert and storm drain inlets and outlets; and other locations as required by city, county, state or federal agencies or governments.

Where limits of disturbance or exclusion areas have been flagged or fenced, Contractor shall keep all vehicles and equipment off of the protected areas.

Temporary controls are to remain in place until disturbed areas have achieved a 70% minimum revegetation rate as compared to the immediate undisturbed surroundings or are permanently stabilized.

For work within a waterbody or stream, follow permitting requirements for the specified work.

At stream crossings, maintain a sufficient flow of water at all times to sustain aquatic life downstream and return the streambed and streambanks as nearly as possible to their original condition or better after the work has been completed.

Follow Manufacturer's recommendations for product installation.

Keep records and logs as required by permits obtained for the work.

3.2 TEMPORARY (CONSTRUCTION) EROSION CONTROLS

Limits of stripping should be minimized and phased as much as practical to reduce the area subject to erosion.

Mulch or soil stabilization additives may be necessary when stripped areas must be left exposed for extended periods.

Drainage channels shall be constructed and placed into service as soon as practical. Armoring and riprap in channels and at culvert inlets and outlets shall be placed as soon as practicable after culverts and channels are constructed.

Topsoil replacement and revegetation is to occur as soon as practicable after construction and finish grading of each phase. For multi-year projects, all disturbed areas shall be adequately revegetated or temporary erosion control measures implemented prior to leaving site for the winter, or November 1, whichever occurs first.



3.3 TEMPORARY (CONSTRUCTION) SEDIMENT CONTROLS

The Contractor shall employ temporary measures such as erosion logs, straw bale barriers, silt fences, check dams, sediment traps and/or other measures as necessary to collect sediment both in the interior of the construction site and at the perimeter of the construction limits to minimize the potential for sediment transport beyond the construction limits.

Controls and measures shall include those specifically shown on the drawings, along the downhill limits of all earth stockpiles, along the downhill limits of phased grading activities and at regular intervals along all drainage channels.

3.4 MAINTENANCE OF TEMPORARY CONTROLS

The erosion and sediment control features shall be checked at intervals required by permits, paying special attention during spring snowmelt and after each significant rainstorm for damage, and maintained by the Contractor. All damaged areas and facilities shall be repaired as soon as possible.

All sediment entrapment facilities shall have the accumulated sediment removed when 50% of their capacity has been reached so as to maintain their storage volume and function.

Perimeter controls shall be relocated as the areas of construction move and as the disturbed areas stabilize.

All sedimentation and erosion control facilities shall be maintained just prior to the onset of winter, no later than November 1.

All temporary erosion and sediment control facilities that have outlived their usefulness shall be removed as part of the final cleanup and all permanent erosion and sediment control facilities shall be maintained at final project acceptance.

3.5 PERMANENT (POST-CONSTRUCTION) CONTROLS

After final grading, the entire disturbed portion of the site shall be revegetated. Drainage channel improvements shall be shaped and revegetated to create vegetated water quality channels. Channels shall be armored where indicated.

Bonded fiber matrix, mulch with tackifier, mulch with jute netting, erosion control blankets or turf reinforcement mats may be necessary in sensitive or steeper areas.

Erosion control blankets and turf reinforcement mats shall be installed on ground which has been cleaned and stripped of all debris, brush, logs, rocks and soil clumps larger than 2 inches in diameter. Erosion blankets shall be placed immediately after seeding, while turf reinforcement mats shall be placed and sequenced with seeding as specifically described. The tackifier included in the mulching specification shall not be necessary where an erosion control blanket or turf reinforcement mat is required.



PART 4 MEASUREMENT AND PAYMENT

Payment for all costs of all labor, equipment and materials required for Erosion and Sediment Control shall be made on a Lump Sum basis per the Erosion and Sediment Control bid item, except that items specifically listed as line items on the bid sheet will be paid for separately. Such payment shall also include all work required for compliance with Permits as required by the State of Colorado Department of Public Health and Environment, Routt County and/or the Town of Hayden, whether or not such work is shown on the Drawings or specified.

A cumulative percentage of the total bid amount will be paid as work progresses, per the following schedule:

After completion of initial installation:	50%
After Preliminary Acceptance/ Substantial Completion:	75%
At the time of Final payment:	100%

Seed, mulch, tackifier and bonded fiber matrix shall be measured and paid for under Section 2821, Revegetation.

If no separate bid item is provided, no separate payment will be made for the work under this section. Its cost shall be considered incidental to the Project.



SECTION 1570 TRAFFIC REGULATION

PART 1 GENERAL

1.1 DESCRIPTION

Work under this Section shall include the regulation of vehicular and pedestrian traffic during performance of the Work. The Contractor shall be responsible for the safe and orderly flow of traffic through and around the project site at all times.

1.2 QUALITY ASSURANCE

Work shall be per:

1. "Manual on Uniform Traffic Control Devices for Streets and Highways", (MUTCD); Federal Highway Administration FHWA), 2009 Edition of the MUTCD with Revisions Numbers 1 and 2 incorporated, dated May 2012.

PART 2 PRODUCTS

All warning signs, barricading, and other necessary items shall conform to the above references and the current Colorado Department of Transportation M & S Standards.

PART 3 EXECUTION

3.1 GENERAL

The Contractor shall provide all necessary signs, barricades, lights and flag persons necessary for the safe and orderly flow of pedestrian and vehicular traffic. Every attempt to keep traffic flow at a normal pace must be made whenever possible. The Contractor shall confine his occupancy of public or traveled ways to the smallest space compatible with the efficient and safe performance of the Work. Traffic is to be restored to normal flow, whenever feasible, at the end of each working day.

It shall be the Contractors' sole responsibility to notify the appropriate authorities at least 48 hours in advance of significant changes in traffic patterns or possible hazards due to reductions of travel surface width or other work in public rights-of-way. The Contractor is to coordinate all detours and temporary road closings with the appropriate authorities.

3.2 SIGNS AND BARRICADES

Properly lighted, adequately sized, concise, legible signs shall be furnished as necessary for the safe regulation of traffic. Any backfilled areas that present a hazard to traffic must be properly protected and signed.

Suitable lighted barriers or barricades shall be furnished by the Contractor and put up and maintained at all times during the night or daytime, around all open ditches, trenches, excavations, or other work potentially dangerous to pedestrian and vehicular traffic. Barricades shall be placed on all sides and throughout the entire length of all open ditches, trenches, excavations, or other work which must be barred to the general public. Barricades shall be properly painted in order to retain a high degree of visibility at all times to vehicular and pedestrian traffic.



3.3 TRAFFIC CONTROL PLAN

The Contractor shall submit a traffic control plan for all major detours and for all complicated traffic control operations to the Engineer and the applicable Regulatory Agencies for review and concurrence well in advance of implementation. The plan must be developed by an American Traffic Safety Services Association (ATSSA) certified individual or professional traffic engineer.

3.4 NON-PERFORMANCE

The Owner immediately, and without notice, may furnish, install and maintain barricades or lights if the Contractor fails to comply with the requirements of this section. The cost thereof shall be borne by the Contractor and may be deducted from any amount due or to become due to the Contractor under this contract.

PART 4 MEASUREMENT AND PAYMENT

Traffic Regulation shall be measured and paid for per the Lump Sum Price under the Traffic Regulation item. A percentage of the total bid amount will be paid as work progresses proportionate to the traffic regulation effort provided for the pay period.

The above payment shall include the cost of all signs, barricades, lights, equipment, tools, and labor incidental or necessary for completion of the Work.

If no bid item for traffic regulation is listed, no separate payment will be made for the work under this section. Its cost shall be considered incidental to the Project.



SECTION 1600
MATERIAL, EQUIPMENT AND WORKMANSHIP

PART 1 GENERAL

1.1 DESCRIPTION

Work under this Section shall establish the general standards for quality of materials, equipment purchases and installation and general project workmanship.

1.2 QUALITY ASSURANCE

- A. All Materials: All materials and equipment supplied for this project shall be new, unused and correctly designed for the intended application. They shall be of standard first grade quality, produced by expert workmen, and be intended for the use for which they are offered. Materials or equipment which, in the opinion of the Engineer, are inferior or of a lower grade than indicated, specified or required will not be accepted.

All materials and equipment supplied shall meet specified performance requirements at the elevation of the project site.

Any two or more pieces of material or equipment of the same kind, type or classification, and being used for similar types of services, shall be made by the same manufacturer.

Where intended for use with potable water, materials and methods shall in general, comply with the appropriate AWWA and NSF standards.

- B. Equipment: Equipment and appurtenances shall be designed in conformity with ANS, ASME, IEEE, NEMA and other generally accepted standards. All equipment supplied shall be of rugged construction and suitable for the intended purpose, under design operating conditions, in the location and climate where they are to be used.

All equipment supplied shall be in accordance with the requirements of the Contract Documents.

Equipment shall be of the approximate dimensions indicated on the Drawings or as specified, shall fit the spaces shown on the drawings with adequate clearances, and shall be capable of being handled through openings provided in the structure for this purpose. Equipment shall be of such design that piping and electrical connections, ductwork and auxiliary equipment can be assembled and installed without causing major revisions to the location or arrangement of any of the facilities.

Where applicable all equipment shall bear a brass or stainless-steel nameplate giving manufacturer's rated capacity, head, speed, horsepower, service factor and any other pertinent operating data.

Equipment shall be of sufficient strength to withstand all stresses which may occur during fabrication, testing, transportation, installation and all conditions of operation. All bearings and moving parts shall be adequately protected against wear by bushings or other approved means and shall be fully lubricated by readily accessible devices. Details shall be designed for appearance as well as utility. Protruding members, joints, corners, gear covers and the like, shall be finished in appearance. All exposed welds shall be ground smooth and the corners of structural shapes shall be mitered.



- C. Machinery: Machinery parts shall conform exactly to the dimensions shown on the working Drawings. There shall be no more fitting or adjusting in setting up a machine than is necessary in assembling high grade apparatus of standard design. The equivalent parts of identical machines shall be made interchangeable. All grease lubricating fittings on equipment shall be of a uniform type. All machinery and equipment shall be safeguarded in accordance with the safety codes of the ANS, applicable state and local codes and with U.S. Department of Labor, Part 1910 Occupational Safety and Health Standards, promulgated under the Occupational Safety and Health Act of 1980 (PL 91-596).

1.3 PRODUCT HANDLING AND STORAGE

All materials and equipment to be incorporated in the work shall be handled and stored by the Contractor in a manner satisfactory to the Engineer and in such a way as to prevent damage or theft of the same.

All materials and equipment subject to corrosive damage by the atmosphere if stored outdoors (even though covered by canvas) shall be stored in a building to prevent injury. The building may be a temporary structure on the site or elsewhere, but it must be satisfactory to the Engineer.

All materials which, in the opinion of the Engineer, have become so damaged as to be unfit for the use intended or specified shall be promptly removed from the site of the work, and the Contractor shall receive no compensation for the damage material or its removal.

All pipe and other materials delivered to the job shall be unloaded and placed in a manner which will not hamper the normal operation of existing facilities or interfere with the flow of necessary traffic or with construction progress.

PART 2 PRODUCTS

No products this Section

PART 3 EXECUTION

General requirements for installation of equipment specified for use on the project shall be as follows:

All equipment shall be installed, equipped and serviced as per the manufacturer's recommendations except as supplemented or modified by the requirements of these Specifications or as directed by the Engineer.

All equipment shall be leveled, plumbed, aligned and wedged into position to fit connecting piping and assemblies without transmitting stresses to the equipment.

Where applicable, equipment base frames shall be anchored to concrete pads with cast-in-place anchor bolts. Dimensions for equipment pads shall be determined by the equipment manufacturer and shall be shown on the Shop Drawings. The base frame shall be grouted solid.

All inlet and discharge piping connections to equipment shall include unions for ease of removal and repair. Waste water from packing shall be piped directly to a drain and not allowed to discharge freely on the floor or elsewhere.

All equipment shall be greased, lubed, oiled, and in all ways properly prepared for start-up by the Contractor per the manufacturer's written recommendations. Where required by these Contract Documents, a qualified service technician shall provide the necessary start-up services.

Ceiling lifting hooks shall be installed above most plant equipment. All hooks shall provide a safety factor of 5 against failure for the equipment gross weight.



All concrete work shall be of first grade quality, meeting the requirements of Division 3 or as specified elsewhere in the Contract Documents. All floors shall be free of ponding and irregularities and shall drain to the outlets provided.

The Contractor shall provide all labor, tools, equipment and coordination necessary to provide compliance with the Contract Documents for leakage, performance, quantity, thickness, efficiency, etc. of installed materials and equipment.

PART 4 MEASUREMENT AND PAYMENT

There shall be no separate measurement or payment for work in this section. Its cost shall be considered incidental to the work.



SECTION 1710 CLEANUP

PART 1 GENERAL

1.1 DESCRIPTION

- A. Work included: Maintain the project site in an orderly manner to the standard of cleanliness described in this Section.
- B. Related work described elsewhere: In addition to the general standards described in this Section, comply with all specific requirements for cleaning and cleanup described elsewhere in the Specifications.

1.2 QUALITY ASSURANCE

- A. Inspection: The Contractor shall conduct regular inspections to verify that requirements of cleanliness are being met.
- B. Codes and standards: In addition to the standards described in this Section, comply with all requirements of other agencies having jurisdiction.

PART 2 PRODUCTS

2.1 CLEANING MATERIALS AND EQUIPMENT

Provide all personnel, equipment, and materials needed to maintain the specified standard of cleanliness.

2.2 COMPATIBILITY

Use cleaning materials and equipment which are compatible with the surface being cleaned, as recommended by the manufacturer of the material and which will not damage the surface being cleaned.

PART 3 EXECUTION

3.1 STORAGE OF MATERIALS AND PERIODIC CLEANUP

Store all items to be used on the Project in an orderly manner allowing maximum access. Stored materials shall not impede drainage or traffic.

Do not allow the accumulation of scrap, debris, waste material, and other items not required for construction of the project on the work site.

At least twice each month, and more often if necessary, collect and remove all scrap, debris, and waste material from the job site and dispose of the same in an appropriate disposal area. Storage of all items awaiting removal from the job site, shall be done in such a manner as to minimize fire hazard or environmental damage.



3.2 FINAL CLEANUP

- A. Definition: Except as otherwise specifically provided, "clean" shall be defined as the level of cleanliness generally provided by skilled cleaners using commercial quality building or site maintenance equipment and materials.
- B. General: Upon completion of the work, remove all tools, surplus materials, equipment, scrap, debris, and waste from the work site.
- C. Site: Unless specifically authorized otherwise by the Engineer broom clean all paved areas on the site and all public paved areas adjacent to the site which were contaminated because of the work. Completely remove all resulting debris. Periodic cleaning during the project may be required to remove debris carried onto public rights-of-way.

Gravel parking or driveway areas within or adjacent to the work site which have had excavated or other loose materials stockpiled on them shall be scraped clean down to the original surface. Replacement of gravel materials may be required to restore the surface to its original condition.

Grassed areas within or adjacent to the work site shall be scraped and raked clean to the original grass or soil level. All stones larger than 2 inches in diameter and other loose debris shall be picked up and removed.

Following completion of the associated work, remove all construction staking lath, stakes, flagging, etc. and dispose of properly. Remove and dispose of all temporary sedimentation and erosion control facilities which have degraded beyond their intended purpose or usefulness.

- D. Structures: Inspect all exterior surfaces and remove all traces of soil, waste material, smudges, and other foreign matter. Remove all traces of splashed materials from adjacent surfaces. If necessary, to achieve a uniform degree of exterior cleanliness, hose down the exterior of the structure. In the event of stubborn stains not removable with water, the Engineer may require light sandblasting or other special cleaning.

Inspect all interior surfaces and remove all traces of soil, waste material, smudges, and other foreign matter. Remove all traces of splashed materials from adjacent surfaces. Removal all paint droppings, spots, stains, and dirt from finished surfaces. Use only appropriate cleaning materials and equipment. Clean all glass inside and outside. Polish all surfaces requiring the routine application of buffed polish, with the polish recommended by the manufacturer.

- E. Timing: Schedule final cleaning and cleanup to enable the Owner to accept a clean, finished project.

PART 4 MEASUREMENT AND PAYMENT

There shall be no separate payment for the work covered in this section, its cost shall be considered incidental to the project.



SECTION 2211 SUBGRADE CONSTRUCTION

PART 1 GENERAL

1.1 DESCRIPTION

A. Work included: The work under this section shall include clearing and grubbing, topsoil removal and replacement, subgrade construction, waste areas, rock excavation, and utility installation for work associated with construction of overlot grading, gravel and paved trails, sidewalks, parking lots, miscellaneous embankment construction, and roadways.

B. Definitions: The following definitions shall apply to work and materials under this Section.

1. Clearing and grubbing materials: Trees, stumps, brush, roots, down timber, rotten wood, rubbish and other vegetation that exists within the construction limits. This item may also include old fences, buildings or other structures as designated on the Drawings or as may be discussed elsewhere in the Specifications.
2. Topsoil: Top layer of loose friable loam that is free of subsoil, refuse, stumps, roots, rocks, brush, weeds, heavy clay, toxic substances, or other material which would be detrimental to its use on the project.

Wetland topsoil material shall consist of the moist, organic soil, including any existing wetland vegetation and seeds, to be excavated from areas as shown on the plans or as directed.

3. Common excavation (cut): The materials, both suitable and unsuitable, that exist above final subgrade elevation that are to be excavated during the subgrade construction or overlot grading including the excavation for roadway/trails ditches.
4. Embankment Materials: The suitable materials acquired from excavations, hauled, and placed in embankments (fills) that are required to raise the prepared existing grade to the final subgrade elevation.
5. Embankment construction: embankment construction shall include preparation of the areas upon which embankments (fill) will be placed; and, placing and compacting of approved material for the purpose of constructing roadway embankments, water retaining berms, dikes, trails, sidewalks, parking lots, and overlot grading fills. Embankments (fills) shall be further defined as follows:
 - a. Embankment: fills for roadways, water retaining berms, dikes, trails, sidewalks, parking lots, and overlot grading fills.
 - b. Structural Backfill: fill placed below the designed final grade and adjacent to structures. The backfill shall continue from the structure wall to tie to excavated walls; or to a point 10' out from structure walls if no excavation walls exist, which ever is further.
 - c. Structural Fill: Fills placed in areas where building foundations or building slabs will be placed.
 - d. General Site Fill: Fills not defined as embankments or structural fills.
6. Trench Backfill: Backfill required following the excavation of trenches for the placement of underground utilities and drainage culverts.



7. Rock excavation: The removal of solid rock masses i.e., shale, Browns Park, etc. which cannot be reasonably ripped, broken, and removed with skillfully operated excavating equipment in the 50,000 lb.+ class, using a 30-36-inch toothed bucket or single shank ripper and operating at a minimum of 70% of rated efficiency; or isolated boulders of 1 cubic yards or larger; or several "nested" boulders of 1/2 cubic yard or larger which act like a single rock-mass.
8. Unsuitable materials: Materials encountered in subgrade construction other than topsoil which contain roots, debris, organic or frozen material, or which contain stones larger than 6 inches in diameter which cannot easily be separated and removed. It also includes soils with excessive moisture such that the soil flows when dumped or cannot be reasonably dried for use in subgrade construction.
9. Suitable materials: Soil materials which can be compacted to form a stable subgrade and which are not classified as unsuitable.
10. Waste material: The following materials may be designated waste materials:
 - a. Clear and grub materials.
 - b. Excess topsoil.
 - c. Excavated Rock.
 - d. Unsuitable material.
 - e. Excess suitable material.
11. Overlot grading: Grading of lots adjacent to a road to provide for site improvements or to provide a balance of cut and fill materials quantities.
12. Borrow: Fill materials that are generated from a source other than the common excavation area of the project that are required to supplement the suitable common excavation material to complete the project embankment fills. Locations of borrow areas may be either designated (described in the specifications or shown on the drawings) or undesignated (to be agreed upon by the Contractor and the Engineer). Borrow from undesignated areas must be approved by the Engineer prior to use on the project.

1.2 QUALITY ASSURANCE

- A. Standards: The following standards shall apply to work under this Section as appropriate.
 1. Reference the most current edition of Standard Specifications for Road and Bridge Construction, CDOT, State of Colorado herein called "Standard Specifications".
 2. Particle Size Analysis of Soils, ASTM D 422
 3. Liquid Limit of Soils, ASTM D 423
 4. Plastic Limit and Plasticity Index of Soils, ASTM D 424
 5. Test method for laboratory compaction characteristics of soil using modified effort, ASTM D 1557.
 6. Test method for laboratory compaction characteristics of soil using standard effort, ASTM D 698.



7. Density of Soil and Soil Aggregate In-Place by Nuclear Method, ASTM D 2922
8. Moisture Content of Soil and Soil Aggregate In-Place by Nuclear Methods, ASTM D 3017
- B. Sampling of Materials: Sampling and delivery of each principal type of material to be used in subgrade construction shall be the responsibility of the Contractor. Samples shall be delivered to the Engineer for testing sufficiently in advance of construction so as to not delay the Work.
- C. Testing of Materials: Testing of materials to be used for subgrade construction shall be performed by the Engineer. General tests may include, but are not limited to, Atterberg limits, mechanical analysis, maximum density and optimum moisture content testing to determine the overall suitability of the materials.

Tests for determination of maximum density and optimum moisture content shall be performed in accordance with the requirements of ASTM D 1557 or ASTM D 698, as specified for each principal type of material or combination of materials encountered or utilized.

PART 2 PRODUCTS

2.1 FILL MATERIAL, GENERAL

- A. Approval required: All fill material shall be subject to the approval of the Engineer.
- B. Notification: For approval of imported fill material, notify the Engineer at least 10 working days in advance of intention to import material, designate the proposed borrow area, and provide the Engineer a sample from the borrow area for the purpose of making acceptance tests to prove the quality of the material.

2.2 SUITABLE FILL MATERIAL

- A. All on-site material suitable for STRUCTURAL BACKFILL and STRUCTURAL FILL shall be soil or soil-rock mixture which is free from frozen material, organic matter, and other deleterious substance. It shall contain no rocks or lumps over 6" in greatest dimension, and not more than 15% of the rocks or lumps shall be larger than 2 1/2" in greatest dimension. It shall be a non-expansive soil.
- B. All on-site excavated material suitable for EMBANKMENT and GENERAL SITE FILL construction shall meet the requirement of suitable material for STRUCTURAL BACKFILL with the following exceptions; materials generated on-site that exceed the maximum 6"-dimension requirement but are less than 12" in dimension may be used for embankment construction within embankments that will allow placement of the over sized materials at least 18" from any final grade or surface, when approved by the Engineer. Expansive soils may be used as fill material in these areas.
- C. Imported Washed/Screened Rock used for a granular cushion, selected pipe bedding, or for subdrain gravel pack shall be washed or screened gravel free from an appreciable amount of fines or any organic or other foreign material. The gradation of the gravel shall be such that the minimum size is 3/8" diameter and the maximum size is 1 1/2" diameter. No more than 15% shall be smaller than 1/2" diameter.
- D. Imported Pit Run shall be well graded Class 3 Aggregate Base Course per Section 703.03 of the *Standard Specifications* with the following modifications:
 1. Crushed reclaimed concrete or asphalt material shall not be used.



2. Percentage passing the 6-inch sieve shall be 100.
3. Percentage passing the No. 4 sieve shall be 30-65.
4. Percentage passing the No. 200 sieve shall be 3-15.

2.3 OTHER MATERIAL

All other materials, not specifically described but required for a complete and proper installation, shall be as selected by the Contractor subject to the approval of the Engineer.

PART 3 EXECUTION

3.1 CLEARING AND GRUBBING

The Contractor shall clear and grub the entire area within the limits of subgrade construction such that no objectionable materials remain to be mixed in with topsoil and other suitable materials. Care should be taken not to leave uprooted objectionable materials along the immediate fringes of the limits of subgrade construction. Excess amounts of salvageable topsoil shall not be removed during the clearing and grubbing process. Contractor may elect to "brush hog" the grass and mix into the topsoil.

All objectionable material removed shall be disposed of at the waste area as designated in the Special Provisions or on the Drawings. If the objectionable material is disposed of on-site, a minimum of 12 inches of topsoil shall be lightly compacted over the debris.

3.2 TOPSOIL

A. Topsoil removal, stockpiling and disposal

1. Topsoil within the limits of the subgrade construction shall be salvaged prior to beginning hauling, excavating, or fill operations by excavating and stockpiling the material at designated locations in a manner that will minimize sediment damage, and not obstruct natural drainage.

Topsoil depths and quantities shown on the Drawings and stated in the Bid are estimates. The actual depths of topsoil to be removed shall be determined by the Engineer during topsoil excavation. Care shall be taken to prevent intermixing of topsoil with suitable subgrade materials.

Topsoil shall be stockpiled in a neat fashion adjacent to the excavation or embankment fill limits for subsequent replacement on cut and fill slopes. Random dozing of topsoil in windrows along the edges of the excavation or embankment fill limits generally results in destruction of the construction stakes and unnecessary destruction of vegetation and so shall not be allowed unless permission is given by the Engineer.

Topsoil quantities in excess of that required to be replaced on cut and fill slopes shall be disposed of in an on-site waste area unless off-site disposal is specified; coordinate with Engineer.

2. Borrow area: Remove topsoil from designated borrow areas to the depths agreed upon by the Engineer. Stockpile the topsoil adjacent to the areas stripped and out of the way of other construction. Maintain all adjacent surface drainage.



B. Topsoil Replacement:

1. Topsoil shall be placed on all disturbed areas not designated for other surface treatments and to the thickness provided in the Contract and shall be keyed to the underlying material. All grass and sod shall be broken up and mixed with the topsoil before placement. When field operations and conditions permit, the Contractor shall stockpile some topsoil on top of the cut slope for periodic replacement as the slope is being cut or "brought down" to the specified subgrade elevation. Early placement of topsoil is desired to encourage the development of a better bond with native materials. Topsoil shall be placed to a depth of 3 inches, unless otherwise specified. After being spread and graded, the topsoil shall be lightly compacted with tracks of a dozer moving up and down the slope. This process is to serve the dual purpose of setting the topsoil in place as well as creating horizontal cleat impressions to retard erosion.
2. Borrow and overlot grading areas: All of the topsoil removed from borrow and overlot grading areas shall be replaced on these areas to the approximate original depths. The topsoil shall be smooth-graded and compacted by track or wheel rolling.

3.3 SUBGRADE CONSTRUCTION

- A. General: Notify the Engineer a minimum of 48 hours in advance of beginning construction. The Contractor shall not excavate beyond the limits established and material shall not be removed prior to staking of the site. Prior to beginning grading operations in any area, all necessary clearing and grubbing and topsoil removal in that area shall have been performed and approved by the Engineer. During construction, the Contractor shall prevent the subgrade or suitable materials from being contaminated with topsoil or other unsuitable materials. Contamination shall also include the incorporation of excessive moisture into subgrade materials do to inadequate surface drainage provisions. Any contamination of the subgrade shall immediately be removed before grading operations continue.

All excavations and embankments shall be finished to a reasonably smooth and uniform surface. The degree of finish shall be that ordinarily obtained from either bladegrader or scraper operations. The surface shall be free of depressed areas where water would pond. All earth slopes shall be finished to reasonably smooth surfaces that will merge with the adjacent terrain without any noticeable break. At intersections of cuts and fills, slopes shall be adjusted and warped to flow into each other or into the natural ground surface without noticeable break. Excavation operations shall be conducted so that material outside of the limits of slopes will not be disturbed.

B. Excavation:

1. Common excavation (cut):
 - a. General: Common excavation materials in roadway/trails and overlot cut areas shall be excavated to the lines and grades as shown on the Drawings or as directed by the Engineer. Suitable materials shall be excavated, transported and deposited at areas to receive fill. Unsuitable materials and excess suitable materials shall be excavated, transported and deposited in the appropriate waste areas.
 - b. Roadway/trails ditches: Ditches shall be cut accurately to the design cross-sections and grades. All roots, stumps, rock and foreign matter in the sides and bottoms of ditches shall be cut to conform to the slope, grade and shape of the section shown.
 - c. Overexcavation: Unauthorized overexcavation shall be backfilled to grade with suitable material meeting the compaction requirements as specified under "Embankment fill".



2. Rock excavation: Before beginning excavation of rock, the Contractor shall notify the Engineer for coordination of measurement and waste area placement. Measurement shall be performed by the Contractor and Engineer prior to removal to the waste area or as appropriate. All boulders and ledge rock encountered in the excavation shall be removed or broken off to a depth not less than 6 inches below subgrade. The resulting area shall be brought to the required grade with compacted suitable material. See Section 2224 Rock Excavation for additional requirements.

C. Subgrade preparation:

1. General: Subgrade preparation shall be the work required preparing the ground surface in fill areas to receive fill, and the work required to compact the surface of the subgrade in cut areas once common excavation materials have been removed. It is also to include grading of the final subgrade including ditches and slopes as well as horizontally scarifying or otherwise roughing the slopes prior to the placement of topsoil.
2. Subgrade preparation in fill areas: The ground surface in all areas to receive fill shall be properly cleared and grubbed. Sloped surfaces steeper than 1 vertical to 4 horizontal on which fill is to be placed shall be plowed, stepped or benched in such a manner that the fill material will bond with the existing surfaces and prevent further slippage. The method of establishing benches and their geometry shall be approved by the Engineer.

The existing ground surface prior to fill placement shall be scarified to a depth of 1 foot and recompacted to 95% of maximum density per ASTM D 698. Any existing ground area within 1 vertical foot of final subgrade elevation shall be scarified to a depth of 12" and then compacted to 95% of maximum density per ASTM D 698.

3. Subgrade preparation in cut areas: The final subgrade surface, which exists in cut areas after the common excavation materials are removed, shall be scarified to a depth of 1 foot and recompacted to 95% of maximum density per ASTM D 698.
4. Preparation of final subgrade surface.
 - a. Immediately prior to the placement of subbase or base course gravels, the subgrade shall be scarified, shaped and compacted to design density at specified moisture content, then proof rolled to identify areas of pumping, checking, or cracking which must be corrected before proceeding further. The Contractor's method of proof rolling shall be as agreed upon by the Engineer prior to proceeding.
 - b. If the final subgrade surface consists of suitable materials, but the compaction standards cannot be met due to excessive moisture content, the Contractor shall be required to dry or manipulate the material to a depth of 1 foot until the proper compaction can be achieved. Use of smaller, lighter equipment may be required to achieve the required density in the natural soils.
 - c. If the final subgrade surface consists of unsuitable material, or suitable material with excessive moisture content which, in the opinion of the Engineer, cannot be dried due to high water table conditions, the section titled "Repair of unstable subgrade" shall apply.

D. Repair of unstable subgrade

1. General: An unstable subgrade is one in which the Contractor cannot meet the compaction requirements called for in "Subgrade preparation" due to:
 - a. Presence of unsuitable materials.



- b. Suitable materials with excessive moisture content which cannot be stabilized by manipulating and drying the top 1 foot.
- c. Presence of groundwater near the subgrade surface preventing proper stabilization of the subgrade.

If such conditions exist, the Contractor shall meet with the Engineer to decide upon the method of solution. The following solutions exist.

2. Solutions to unstable subgrade:

- a. Unsuitable materials and suitable materials with excessive moisture content may be excavated and disposed of at the appropriate waste area. The excavation may subsequently be filled with on-site excess suitable materials or with suitable material from a borrow area.
 - b. Alternatively, suitable materials with excessive moisture content may be excavated, dried by manipulation or mixing with other dry materials and recompactd in the excavation.
 - c. Installation of underdrains: If groundwater exists, underdrains may need to be installed.
 - d. Geotextiles: The Engineer may direct that ground stabilization geotextile be installed. In this case, the geotextile shall be installed over the unstable subgrade in accordance with the manufacturer's recommendations and as described in Section 2242, Geotextiles.
3. For all solutions to stabilizing a subgrade, the Contractor shall meet the requirements called out in "Subgrade preparation". If, however, unstable subgrades exist below 3 feet from finished grade and after a reasonable but unsuccessful attempt by the Contractor to stabilize the subgrade, the Engineer may waive the requirements for subgrade preparation. In such a case, the Engineer may direct the Contractor to place suitable fill over the unstable area.

E. Embankment fill:

1. General: The maximum lift permitted shall be 6 inches. No rocks or stones larger than 6 inches will be allowed in the fill. Rocks greater than 6 inches occurring in otherwise suitable fill shall be removed to the appropriate waste area or to the toe of the fill with prior approval of the Engineer.

Complete such additional items as; placement of subdrains, gravel pack, geotextile, dampproofing, and concrete patching etc.; and, receive the Engineers approval prior to placing any structural backfill material.

All embankment construction shall be completed under moisture and density control.



2. Compaction requirements:

Item	Standard Proctor ⁽¹⁾ (%)
Structural fill	100
Structural backfill	95
General site fill	95
Subgrade preparation	
Base of fill areas	
Fill >1'	95
Fill < 1'	95
Base of Cut areas	95
Embankment	
all except top 2'	95
top 2'	95
Subbase course	95 ⁽²⁾
Base course	95 ⁽²⁾
Special areas	95
Penetrations into water retaining berms	95
Landscape berms	90
Trenches	See Trenching, Bedding and Backfill

⁽¹⁾ As determined by ASTM D 698

⁽²⁾ As determined by ASTM D 1557

3. Moisture content: The Moisture content shall be within **2 percent +/-** of optimum; unless indicated otherwise in the project soils report or directed otherwise by the project soils engineer. If materials are unstable at specified moisture content, then moisture content shall be reduced until materials are stable.

F. Rock Fill: Rocks greater than 6" in diameter are ordinarily not permitted in the fill. When called for in the Special Provisions and agreed by the Town of Hayden embankments may be constructed of rock fill. Rock fills may be used only when large amounts of rock exist and large fills are required. Approval of the Engineer must be obtained before placement of any rock fill. When rock fills are allowed a uniform gradation of large to small rocks shall be placed to prevent large voids from occurring.

G. Offsite borrow: When projects require additional suitable material for fill other than what is on-site, and adjacent overlot cut is not available, an off-site borrow area may need to be established. The Contractor shall be responsible for locating suitable off-site borrow areas within a reasonable distance from the site if no off-site borrow area is designated in the Specifications or on the Drawings. The Contractor shall excavate the suitable materials from the approved borrow area and transport them to the required fill areas.

Upon completion of the work, the borrow area shall be smooth graded to blend into the existing contours with no cut slopes steeper than 3:1. Proper drainage shall be maintained within and around the borrow area at all times.

H. Drainage

1. General: At the onset of construction, the Contractor shall take whatever steps are deemed necessary to protect all work from damage due to inadequate drainage, to protect suitable materials from obtaining additional moisture, to assist in drying of existing materials with excessive moisture and to protect the site from excessive erosion. During construction the embankments and excavations shall be kept shaped and drained. Ditches and drains along the sub-grade shall be maintained in such a manner as to drain effectively at all times.



Excavation and fill shall be performed in a manner and sequence that will provide proper drainage at all times. Additional work to dry materials with excessive moisture content due to rain or snow or lack of proper drainage shall be the responsibility of the Contractor.

2. Culverts and riprap: Culverts as required shall be constructed along the subgrade in a timely fashion to provide proper drainage.
3. Drainageways: Care should be taken in construction of drainageways to minimize disturbance of existing vegetation adjacent to the drainageways.

3.4 WASTE AREAS

- A. General: At the preconstruction meeting, the Engineer and Contractor shall establish which waste materials are to be deposited in the on-site or off-site waste areas. The locations and depths of the materials to be placed in the waste areas shall also be established. No compaction other than that achieved by equipment during smooth grading will be required for waste areas, unless specified in the Special Provisions.
- B. On-site waste areas: On-site waste areas may be as designated on the Drawings or as agreed upon by the Contractor and Engineer at the preconstruction meeting. On-site waste areas will be located within the project site.

The Contractor may, with prior permission of the Engineer, waste excess topsoil along the toe of fill slopes. However, such materials placement may require special placement considerations.

- C. Off-site waste area: Off-site waste areas may be as directed in the Drawings and Specifications or as agreed upon by the Contractor and Engineer at the preconstruction meeting.
- D. Grading of on-site waste area: Upon completion of use of the on-site waste area, it shall be graded to a smooth and uniform grade compatible with the surrounding terrain. All material shall be blended into existing contours. No fills shall be placed in excess of 3 vertical feet on any exposed face. Fill slopes shall not be in excess of 5:1.
- E. Removal of excess materials: The Contractor may not remove excess topsoil and other waste material from the site without the Owner's approval.

3.5 UTILITIES INSTALLATION

It shall be the Contractor's responsibility to coordinate the installation of other utilities such as gas, electric and telephone within the construction area. For the most part, such utilities shall be located outside the shoulders of the subgrade; however, at times the lines may be installed in the shoulders, and occasional road crossing shall be required. No utilities; gas, electric, telephone, CATV, sewer and water lines are to be installed until the subgrade is constructed to grade.

3.6 FIELD QUALITY CONTROL

The Contractor shall develop quality control procedures as necessary to control his installation procedures and assure that his work meets the requirements of the specifications.

The Engineer may perform periodic tests of in place soil density and moisture content during the progress of the work. The Contractor shall schedule his operations to allow the Engineer ample time for testing. The Engineer may make as many tests as he deems necessary.

If certain areas of the subgrade are unstable or suspect to the Engineer, the Engineer may require density tests below the surface of the suspect subgrade. In such instances, backhoe pits shall be dug for testing purposes and then backfilled to required compaction standards by the Contractor.



Testing by the Engineer will not relieve the Contractor from responsibility for the work.

Deficiencies in construction as determined by in place density tests shall be immediately corrected by the Contractor at no additional cost to the Owner.

3.7 GRADING TOLERANCE

A. General: Except as otherwise directed by the Engineer, perform all rough and finish grading required to attain the elevations shown on the Drawings.

B. Grading tolerances:

Subgrade:	+/- 0.1 foot Vertical
	+/- 0.1 foot Horizontal

Rough grade:

1. Building and parking areas:	+/- 0.1 foot
--------------------------------	--------------

Finish grade:

1. Granular cushion under concrete slabs:	+/- 0.05 foot
2. Road base and subbase course:	+/- 0.05 foot
3. Site fills, embankments:	+/- 0.1 foot

C. Treatment after completion of grading: After grading is completed and the Engineer has finished his inspection, permit no further excavating, filling, or grading except with the approval of and inspection of the Engineer.

Use all means necessary to prevent erosion of freshly graded areas during construction and until such time as permanent drainage and erosion control measures have been installed.

PART 4 MEASUREMENT AND PAYMENT

4.1 CLEARING AND GRUBBING

The work performed shall be paid for on a lump sum basis per the appropriate Bid item. The price shall include removal, transporting and disposal to the appropriate waste area.

4.2 TOPSOIL

The Contractor shall be paid for handling topsoil in the following manner.

A. Excavation of topsoil from disturbed areas: Topsoil excavation shall be paid for per cubic yard as measured in the excavation area. Quantities of topsoil shall be calculated by the following procedure. The excavated depth shall be measured at the centerline and at the two slope stake points. The width will be the distance measured between the slope stakes. Depth and width measurements as defined will be taken at 50-foot stations and the Average End Area Method shall be used to calculate the quantity for payment. Payment for this item shall include temporary stockpiling and/or disposal in an on-site waste area. It shall also include smooth grading of the on-site waste area.

B. Topsoil replacement on disturbed areas: Topsoil replacement shall be paid for per cubic yard as measured on the slopes after placement. Field measurements of the topsoiled area shall be made, or the area may be calculated from as-built cross sections. The payment quantity shall be calculated using this area and the design depth.



- C. Excavation and Replacement of topsoil on borrow and overlot grading areas: This shall be paid for as measured in the topsoil excavation area. The depth of topsoil removed shall be measured at grid points. The area of the borrow area shall be measured using the grid system. Quantities of topsoil shall be determined using the Truncated Prism Calculation Method. This item shall include removal of topsoil, temporary stockpiling and replacement of the topsoil.

4.3 SUBGRADE CONSTRUCTION

A. Excavation:

1. Common Excavation (cut): Common excavation shall be paid for on a lump sum basis or per cubic yard as measured in the place of excavation; as provided in the Bid Form. Common excavation is measured from the ground line remaining after topsoil is removed down to the final subgrade line. Quantities shall be calculated using the Average End Area Method. Payment for common excavation shall include the cost of excavation, transporting and depositing the material in fill areas or at an on-site disposal area. If suitable excavated materials are temporarily stockpiled before placed in fills, no extra payment will be received for the stockpiling. Excavation classified as rock excavation will not be paid under the common excavation item but will be paid only under the rock excavation item.
2. Rock excavation: Payment for rock excavation shall be on a cubic yard basis and shall include excavation and removal to an appropriate waste area. Measurement for payment shall be performed in an appropriate manner agreed upon between the Contractor and the Engineer; generally, it shall be measured in place prior to removal.

- B. Embankment fill: Embankment fill shall be paid for on a lump sum basis or per cubic yard as measured in place; as provided in the Bid Form. Fill depth is measured from the ground line remaining after topsoil is removed up to the final subgrade line. Quantities shall be calculated using the Average End Area Method. Payment for fill shall include the cost of shaping and compaction of the fill materials with the proper moisture and density control.

- C. Rock fill: Payment for rock fill shall be per the appropriate Bid item and shall be further defined in the Special Provisions.

- D. Off-site Borrow: Payment for borrow shall be per cubic yard measured in the borrow area and shall include the cost of excavation, loading, haul and depositing at the fill area. Truck or scraper counts shall also be kept by the Contractor.

- E. Subgrade preparation: Payment for the work required for subgrade preparation for both cut and fill areas shall be lump sum per the appropriate Bid item.

- F. Repair of unstable subgrade: Four general methods of payment exist for repair of unstable subgrade, depending on the method of solution.

1. Unsuitable materials and suitable materials with excessive moisture content are excavated, disposed of at the appropriate waste area, and the excavation subsequently filled with on-site excess suitable materials or with other suitable material. The Contractor shall receive payment for excavation of the unsuitable or wet materials per cubic yard measured in the excavation. He shall receive additional payment for filling the excavation with suitable materials as measured in place per the appropriate Bid item.
2. Suitable materials with excessive moisture content are excavated, dried by manipulation or mixing with other dry materials and recompacted in the excavation. The Contractor shall be paid on a time and materials basis for such work.



3. If underdrains are installed, payment for the installation of washed rock and pipe for underdrains shall be per the appropriate Bid item.
 4. If geotextiles are installed, measurement and payment shall be per square yard of material installed under the appropriate Bid item.
- G. Drainage: No additional payment for temporary drainage control during construction shall be made. Permanent drainageways will be paid for per lineal foot of drainageway.
- H. Compaction Tests: No separate payment will be made for excavation and backfill of test holes for compaction testing purposes.
- I. Soil Testing: If the Contractor proposes the use of borrow sources other than those designated in the Specifications or Drawings, the Contractor shall provide the necessary samples and be responsible for testing at no cost to the Owner.

4.4 WASTE AREAS

- A. Measurement: Care should be taken when placing materials in the waste areas to allow for separate in place measurement of the various types of waste materials for payment. Measurements in the waste area shall be made using a grid system and the Truncated Prism Calculation Method.
- B. Payment for material placed at on-site waste areas: The Contractor shall receive no extra payment for on-site wasting of excavated materials.
- C. Payment for material placed at off-site waste areas: The Contractor will receive additional payment for off-site disposal of waste materials. The additional payment will be the cost over and above the cost of excavating the waste materials and disposing of them on-site. Payment for off-site disposal of waste materials will be per cubic yard measured in the waste area. The Contractor shall submit to the Engineer, on a daily basis, a truck count as a check for waste material quantities.
- D. Grading: No additional payment will be made for grading of waste areas.



SECTION 2221
TRENCHING, BEDDING AND BACKFILL

PART 1 GENERAL

1.1 DESCRIPTION

Work included: Excavation, dewatering, preparation of the trench bottom; installation of foundation, bedding, and shading material; backfill, and disposal of waste material for the installation of pipelines, manholes, and their related appurtenances.

1.2 QUALITY ASSURANCE

Reference the most current edition of Standard Specifications for Road and Bridge Construction, CDOT, State of Colorado herein called "Standard Specifications".

1.3 SUBMITTALS

Samples: Supply samples of all imported materials to the Engineer. Supply laboratory test results to assure compliance with the specifications if requested by the Engineer.

1.4 DEFINITIONS

- A. Earth excavation: shall include all soils and loose, broken and laminated ledge rock or stones and boulders which can be reasonably ripped, broken, and removed with skillfully operated excavating equipment in the 50,000 lb. + class, using a 30-36-inch toothed bucket or single shank ripper and operating at a minimum of 70% of rated efficiency.
- B. Rock excavation: shall include all solid rock masses which cannot be excavated as specified under "Earth Excavation" and isolated boulders exceeding 1 cubic yard in size.
- C. Unsuitable material: shall include all materials that contain roots, debris, organic, frozen, unstable or unshapable materials or stones having a maximum dimension of 12 inches or greater and that are determined by the Engineer as unsuitable for providing a proper foundation, embedment or backfill.

PART 2 PRODUCTS

2.1 MATERIALS

A. Foundation Materials:

Imported:

- a. ¾-inch minus. Class 6 Aggregate Base Course, Section 703 of the Standard Specifications.
- b. 1-1/2 inch washed. Number 467 Coarse Aggregate for Concrete, Section 703 of the Standard Specifications.



B. Bedding and Shading Materials:

1. Native: These materials are generated on site originating from the excavated trench material. Classifications per ASTM D2487.
 - a. Coarse sand and gravels with maximum particle size 1-1/2 inch including variously graded sands and gravels containing small percentages of fines, generally granular and non-cohesive when wet or dry. Soil types GW, GP, SW, and SP are included in this class. **This classification is not suitable when polyethylene encasement is specified.**
 - b. Fine sand and clayey gravels, including fine sands, sand-clay mixtures, and gravel-clay mixtures. Soil types GM, GC, SM, and SC are included in this class.
 - c. Silt, silt clays and clays including inorganic clays and silts of medium to high plasticity and liquid limits. Soil types MH, ML, CH and CL are included in this class. These materials are not permissible for use in the pipe embedment zone without the specific approval of the Engineer.
 - d. Organic soils OL, OH, and PT as well as soils containing frozen earth, debris, rocks larger than 2 inches maximum dimension, excessively wet native materials and other foreign materials. These materials are not permissible for use in the pipe embedment zone under any conditions.
2. Imported:
 - a. 3/4-inch minus. Class 6 Aggregate Base Course per Section 703 of the Standard Specifications.
 - b. 3/4 inch washed. Number 6 or Number 67 Coarse Aggregate for Concrete per Section 703 of the Standard Specifications.

C. Backfill Materials:

1. Native: Suitable material; shall include all materials which are not classified as unsuitable.
2. Imported: Pit run; Class 3 Aggregate Base Course per Section 703 of the Standard Specifications with the following modifications. Material to be 6 inch minus reasonably well graded pit or bank run material.
3. Flow Fill: Shall conform to Section 206.02(a) of the CDOT Standard Specifications, or approved equal.

D. Selection of Material:

The following guidelines shall apply for selection of imported Foundation and Embedment Zone materials.

<u>Zone</u>	<u>Recommended material</u>	
	<u>Wet Conditions</u>	<u>Dry Conditions</u>
Foundation	1-1/2" Washed Rock	3/4" minus
Bedding	3/4" Washed Rock	3/4" minus
Shading	3/4" Washed Rock	3/4" minus



PART 3 EXECUTION

3.1 TRENCH EXCAVATION

- A. General: Limit operations to as small an area as possible in order to minimize damage to adjacent property. If necessary clear and grub the area to be excavated. In areas where topsoil exists remove and salvage the topsoil for replacement. Keep topsoil segregated from other excavation materials.

The maximum amount of trench left open at one time shall be limited to 100 feet or such length as the Engineer considers reasonable and necessary. No trench shall be left open over night unless specified otherwise in the Special Provisions.

A guide for desirable trench width at the top of the pipe shall be the nominal diameter of the pipe plus 12 inches on each side of the pipe. If a trench box is used, trench width shall be such as to allow a minimum dimension of 6" between the trench box and the outside of the pipe.

All utility lines and water courses met shall be maintained and provided for by the Contractor without damage, or nuisance to other parties.

Shoring, bracing, sheeting, other trench support methods, and trench boxes shall be used when necessary to protect the work, property and persons. The need, appropriateness and adequacy of all such devices shall be the responsibility of the Contractor.

Unless indicated specifically in the Project Special Provisions or on the drawings, Native materials are considered unsuitable materials for foundation, bedding, or shading materials; imported materials must be used.

- B. Alignment and Grade: The trench shall be excavated so that the pipe can be installed to the alignment and grade indicated on the Drawings or specified. Under certain field conditions the Engineer may authorize water main to be installed with less than or more than the specified minimum cover.

It is the Contractor's responsibility to plan far enough in advance of pipelaying operations to allow grade adjustments to be implemented to provide proper clearances when crossing existing utilities.

In subdivision work, or other work requiring changes to existing grade along the centerline of a proposed pipeline, the changes shall be made to subgrade elevation prior to installation of the line.

- C. Dewatering: The Contractor shall provide all necessary dewatering equipment and procedures necessary for excluding and removing water from trenches, and other parts of the work.

The trench shall be maintained dry so that the work may be completed efficiently, and pipes can be laid, joined, bedded, inspected and backfilled in dewatered conditions. The pipe shall not be used to dewater the trench. No water shall be allowed to flow over or rise upon fresh concrete or mortar, and no water shall be allowed to enter the pipe.

The water shall be disposed of by the Contractor in accordance with the Contract Documents and applicable laws and regulations. The Contractor is responsible for obtaining all necessary dewatering or discharge permits and complying with their requirements.



3.2 FOUNDATION

- A. General: Verify that a sound stable trench bottom free from soft, loose, rocky, excessively hard or other unsuitable native material exists before proceeding.
- B. Required Foundation: Install imported foundation material at all locations unless native materials are specifically indicated as acceptable on the Drawings or Specifications.
- C. Unsuitable Foundation: Where unsuitable foundation is encountered over-excavate the trench bottom to the depth authorized by the Engineer and bring the foundation to grade with the appropriate imported foundation material authorized by the Engineer and compacted in lifts to 95 % of maximum dry density.

3.3 BEDDING AND SHADING

- A. General: Holes for pipe bells shall be provided at each joint. Bell holes shall be no larger than necessary for joint assembly and assurance that the pipe barrel will lie flat on the trench bottom. Generally, 2 inches of clearance beneath the joint is desirable. Push-on type joints require only minimum depressions for bell holes. In no case shall the bell support the weight of the pipe at the time of shading and backfill. Under no circumstances is the pipe to be permanently joined in the trench until the trench bottom has been fine graded to provide uniform pipe support at the required invert elevation.
- B. Required Embedment: Install imported bedding and shading material at all locations unless native materials are specifically indicated as acceptable on the Drawings or Specifications.
- C. Native Bedding and Shading: If allowed in the Project Special Provisions, when trench bottom soil can be cut and shaped accurately and with little difficulty, the Engineer may authorize pipe to be installed directly on a shaped trench bottom. The shaped surface is to contact and support the pipe barrel continuously between joints. Irregularities such as lumps, ridges, hollows, etc., which will cause uneven bearing of the pipe are to be shaved off or filled, as appropriate, with compacted native embedment to provide uniform barrel support.
- D. Imported Bedding and Shading: Unless indicated otherwise, the Contractor shall provide and place suitable imported materials in the Embedment Zone.
- E. Procedures for Bedding and Shading: The following procedure shall be used for all types of pipe. Special care is required in the Embedment Zone to assure proper filling and compaction of materials beneath pipe haunches and to avoid displacing or damaging the pipe. Bedding and shading materials shall be placed in a minimum of two lifts. The thickness of the first lift shall not exceed the pipe spring line. Following placement of the first lift a "tee bar" shall be used to compact loose material under the pipe haunches. The use of the end of a shovel handle to compact under pipe haunches is not considered an acceptable alternative to a "tee bar". Mechanical compaction may be required at the first lift as well as succeeding lifts for pipe diameters larger than 12 inches or where dictated by trench width.

Depending on the diameter of the pipe being installed, installation of shading materials may require a single lift or multiple lifts. Lift thickness from the spring line or top of bedding to the top of shading shall not exceed 18 inches.

Embedment Zone materials shall be placed by hand shoveling, or by careful placement with a backhoe. Dumping or shoving excavated materials over the trench sidewall, and "chipping" of soil from the top of the trench are not considered acceptable means of shading the pipe. Embedment Zone materials shall be compacted to 95% of maximum dry density. The method of compaction used by the Contractor to obtain the required density is subject to the Engineer's review. If the specified compaction is not being obtained, the Contractor will be required to modify his



compaction procedures to meet specified requirements. This may require the use of other types of compaction equipment or a reduction in size of lifts being compacted.

Any damages to the pipe which may occur from improper compaction procedures or the use of mechanical compaction too close to the pipe shall immediately be repaired by the Contractor. If compaction equipment which is narrower than full trench width is used, the equipment shall be operated first on each side of the pipe between the edge of the pipe and the trench walls and then centered over the pipe.

Horizontal placement of bedding and shading shall extend the full trench width to undisturbed trench wall material.

3.4 TRENCH BACKFILL

- A. General: Backfill materials shall be placed in lifts and compacted to 95% of maximum dry density. Road crossings will, in general, be backfilled with imported material.

Unpaved Areas: Backfill materials shall be placed in lifts and compacted to 95% of maximum dry density as determined by ASTM D698 (Standard Proctor).

Graveled and Paved Areas: Imported backfill materials shall be per Geotechnical recommendations. Backfill materials shall be placed in lifts and compacted to 95% of maximum dry density as determined by ASTM D698 (Standard Proctor). The upper 12 inches of the backfill zone (that lies below road base or subbase material) shall be compacted to at least 98% of maximum dry density as determined by ASTM D698 (Standard Proctor).

Utility Trench Backfill Material for Public Paved Road Crossing: In instances where a trench transversely crosses a paved public street, the upper 12-inches that lie below the pavement shall be backfilled with flow fill.

Salvaged topsoil shall be replaced to its approximate original depth in all open areas and areas to be revegetated.

- B. For Manholes Located in Gravel Or Paved Areas: Backfill materials shall be compacted to 95% in lifts recommended not to exceed 6 inches.
- C. Deviations/material moisture content:
1. Excessive moisture content: The Contractor shall attempt to dry wet backfill material to the specified moisture content. If wet native backfill cannot be compacted to the specified requirements after reasonable drying effort by the Contractor, the Engineer may waive the compaction requirement, or may authorize the Contractor to use imported backfill material. Where only the upper portion of the trench section is backfilled with imported material the Contractor shall install geotextiles as authorized by the Engineer to separate the imported and native materials.
 2. Insufficient moisture content: Where compaction requirements cannot be met because of insufficient moisture content, the Contractor will be required to add moisture to the material as required for proper compaction.
- D. Flooding and Jetting of Trenches: Flooding or jetting of trenches shall not be permitted unless specifically approved by the Engineer.



3.5 WASTE

It shall be the Contractor's responsibility to remove all excess materials or unsuitable materials remaining from excavation, trenching or other work and dispose of the same in compliance with all applicable laws and regulations.

3.6 FIELD QUALITY CONTROL

Compaction Requirements: The Trench Backfill shall be specified by the Engineer in the Special Provisions or on the Drawings.

- A. Compaction: The Contractor shall test materials installed to control installation procedures and to verify, for the record, that proper compaction has been attained.

Testing will include as a minimum, moisture density relations and density in place for each type of material encountered. The frequency of testing shall be as necessary to assure the installed material has been properly compacted but shall be no less than 1 test per type of material placed, per 100 ft. of trench. Any failed tests must be retaken to show that proper compaction has been achieved.

The degree of bedding or backfill compaction specified shall be the percent of maximum dry density as determined by ASTM D 698, Standard Proctor.

The moisture content of bedding or backfill materials shall be within 2% of optimum moisture as determined by ASTM D 698. If materials are unstable at specified moisture content, moisture content shall be reduced until materials are stable.

Compaction tests will be performed on the surface that exists at the time of the test. If compaction testing, or other visual observations, indicate the possibility of inadequate compaction at a lower depth, the Engineer may require the Contractor to re-excavate to a lower depth to allow for additional testing.

When a trench will be paved with a bituminous or portland cement concrete pavement, or when requested by the Engineer, the Contractor shall proof roll the trench with a loaded front end loader or truck of sufficient size to determine if soft spots exist.

When tests indicate inadequate compaction, the Contractor shall recompact the material. In cases where there is repeated failure to meet specified compaction, the Engineer may require that the backfill be removed and recompact in 6-inch lifts or replaced with imported material at the Contractor's expense.

- B. Trench Settlement:

1. General: Variations in soil type and moisture conditions along with inconsistencies in compactive effort may cause settlement to occur in portions of the backfill. The specified compaction requirements shall be considered a minimum. Spot testing of in-place density by the Engineer during construction shall not relieve the Contractor of the responsibility to assure that the trench backfill does not settle beyond the limits established below. The Contractor shall be responsible for repair of areas of excessive settlement.

2. Measurement: Measurement of settlement shall generally take place in July or August, one winter season following completion of trench backfill.



3. Limits: The following limits to trench backfill settlement shall apply.
 - a. Asphaltic Concrete Paved Areas: Settlement greater than 1/2 inch but less than 1-1/2 inches shall be repaired by removing the asphalt to a minimum of 2 feet on either side of the settled area and replacing it with a new, thicker section of asphalt to produce a final level surface. Settlement greater than 1-1/2 inches shall be repaired by removing the asphalt and recompacting or replacing the trench backfill and gravels and then applying a new asphalt surface.
 - b. Gravel Surfaces: The Contractor shall add additional compacted gravel to trenches where settlements are less than 1-1/2 inches. In cases where the settlement is greater than 1-1/2 inches the Contractor shall be required to replace and recompact backfill material as necessary.
4. Warranty: When settlement of trenches necessitates repair, the warranty period for the trench repairs shall be extended one year beyond the time of the repairs.

PART 4 MEASUREMENT AND PAYMENT

Trench Excavation and Backfill:

- A. Native Materials: No measurements or separate payment will be made for excavation and backfill of native materials. The costs for this Work shall be included in the Prices bid for the item being installed, except that rock excavation will be paid for as described below.
- B. Required Foundation Materials: No measurements or separate payment will be made for excavation and backfill with imported foundation or bedding and shading materials when the materials are shown or specified as part of the standard installation. The costs for this Work shall be included in the Prices bid for the item being installed, except that rock excavation will be paid for as described below.
- C. Imported Foundation Zone Materials: Measurement and payment for removal of unsuitable foundation material and replacement with imported material shall be per the Unit Price per Cubic Yard measured by the length of material installed times the payment width limit shown on the Drawings times the actual authorized thickness of material replaced under the item Foundation Zone by material type.
- D. Imported Bedding and Shading Material: Measurement and payment for imported bedding and shading material when the material is not shown or specified as part of the standard installation (i.e. the material is installed at the Engineer's option) shall be made at the Unit Price per Cubic Yard measured by the length of material installed times the payment width limit shown on the Drawings times the actual depth of material authorized less the volume of the pipe installed per the Bedding Zone or Shading Zone item by material type.



- E. Imported Backfill: Measurement and payment for imported backfill shall be per the Unit Price per Cubic Yard measured by the length of material installed times the payment width limit shown on the Drawings times the actual authorized thickness of material replaced under the item Imported Backfill.

- F. Rock Excavation: Measurement and payment for rock excavation shall be in addition to any payment received for other types of excavation and shall be at the Unit Price per Cubic Yard based upon the quantity of material authorized removed measured in place under the item Trench Rock Excavation. The maximum payment width shall not exceed the trench payment width shown on the Drawings. The maximum payment depth shall not exceed 6 inches below the pipe invert or manhole bottom. The Contractor shall notify the Engineer prior to excavating rock to allow measurements of rock to be verified. Failure to do so will result in non-payment for all rock excavated prior to the Engineer's confirming measurements.



SECTION 2261 RIPRAP

PART 1 GENERAL

1.1 DESCRIPTION

Work included: Furnishing and installing rip rap to include preparation of the surface to receive rip rap as shown on the Drawings or required.

1.2 QUALITY ASSURANCE

Standard Specifications: Materials, and installation shall be in accordance with the most current edition of Standard Specifications for Road and Bridge Construction, CDOT, State of Colorado herein called "Standard Specifications".

1.3 SUBMITTALS

Submit the source of the riprap to the Engineer for review prior to transporting and placing riprap. Provide the samples of riprap only if requested by the Engineer.

PART 2 PRODUCTS

MATERIALS

Per section 506.02 of the standard specifications. If no stone size is shown on the Drawings, the stone size (d50) shall be 12 inches.

PART 3 EXECUTION

3.1 PREPARATION

Earth surfaces on which the rock riprap is to be placed shall be trimmed and graded to conform to the lines or sections shown on the Drawings. Surfaces which are below grade shall be brought to grade by filling with well-compacted materials similar to the adjacent materials.

3.2 INSTALLATION

Per section 506.03 of the standard specifications modified as follows. The riprap shall be placed to the full course thickness in one operation and in such a manner as to avoid displacement of the underlying materials. The finished surface of the riprap shall be slightly below the adjacent ground surface and shall slope toward the center of the riprap installation.

PART 4 MEASUREMENT AND PAYMENT

The quantity of rock riprap will be determined from the specified thickness shown on the Drawings and the area on which acceptable placement has been made. Total quantities will be computed to the nearest cubic yard.

Payment will be made at the Contract Price per cubic yard under the appropriate Bid Item.



SECTION 2521
CULVERT PIPE AND INSTALLATION

PART 1 GENERAL

1.1 DESCRIPTION

Work included: Work shall include furnishing and installing culvert pipe for surface drainage, sub-drainage, or casing pipe applications. For the purposes of these documents, corrugated metal pipe (CMP) shall be either corrugated steel pipe or corrugated aluminum pipe as specified in these documents.

1.2 QUALITY ASSURANCE

All workmanship and materials shall comply with the most current edition of Standard Specifications for Road and Bridge Construction, CDOT, State of Colorado herein called "Standard Specifications".

PART 2 PRODUCTS

2.1 CULVERT MATERIAL

A. Corrugated Metal Pipe:

1. Corrugated Steel Pipe:

- a. Fabricated pipe, coupling bands and end sections: shall meet or exceed the requirements of AASHTO M-36. Minimum steel gage shall be as follows:

<u>Pipe diameter or equivalent arch</u>	<u>Gage</u>
a. Up to 48"	16
b. 54" to 66"	12
c. Over 66"	10

- b. Structural Plate pipe: shall meet or exceed the requirements of AASHTO M-167. Steel shall be 12-gage unless otherwise specified.
- c. Aluminized Steel Type 2 Pipe Material: shall meet the requirements of AASHTO M-274.

2. Corrugated Aluminum Pipe:

- a. Fabricated pipe, coupling bands and end sections: shall meet or exceed the requirements of AASHTO M-196. Minimum aluminum gage shall be as follows:

<u>Pipe diameter</u>	<u>Gage</u>
a. Up to 30"	16
b. 36" to 54"	12
c. 60" to 66"	10
d. Over 72"	8

- b. Structural Plate Pipe: shall meet or exceed the requirements of AASHTO M-219. Aluminum gage shall be per the manufacturer's recommendation and subject to approval by the Engineer.



Coupling Bands: Shall be either one or two-piece lap-type of the same material as the pipe. Band width shall be 7 inches for 6 inch through 18-inch diameter pipe, 12 inches for 21 inch through 60 inch and 24 inches for diameters greater than 60-inch. Bands for use with culverts through water impounding embankments or in other applications where a watertight joint is important shall include a neoprene gasket.

- B. High Density Polyethylene Pipe: Shall be high density polyethylene corrugated exterior/smooth interior pipe. 4 inch through 10-inch diameter shall conform to the requirements of AASHTO M-252. 12 inch through 48-inch diameter shall conform to the requirements of AASHTO M-294, Type S. Material shall meet ASTM D1248 Type III, Category 4, Grade P33, Class C; or ASTM D3350 Cell Classification 324420C.

Coupling Bands shall meet the soil-tightness requirements of the AASHTO Standard Specification for Highway Bridges, Section 23, paragraph 23.3.1.5.4 (e). Bands for use with culverts through water impounding embankments or in other applications where a water tight joint is important shall include a gasket made of closed cell synthetic expanded rubber meeting the requirements of ASTM C1056, Type 2.

Pipe fittings shall conform to AASHTO M-252 or M-294.

- C. Reinforced Concrete Pipe: Shall conform to the requirements of AASHTO M 170. The use of elliptical reinforcement in circular pipe is optional.

Elliptical pipe shall conform to AASHTO M 207. Arch pipe shall conform to AASHTO M 206.

Precast reinforced concrete end sections shall have at least one line of reinforcement conforming to the requirements of AASHTO M 170 equivalent to the square inches per linear foot for elliptical reinforcement in circular pipe, Class II, Wall B.

- D. Coating: Bituminous coating material for culverts, where specified, shall conform with the requirements of AASHTO M-190, Type A coating or AASHTO M-243, except that the use of tar base material will not be permitted.
- E. Perforations: Perforations where specified shall be arranged in two groups of longitudinal rows placed symmetrically on either side of an unperforated segment corresponding to the flow line of the pipe. Within each group, the rows of perforations shall be spaced circumferentially approximately 1-inch center to center. In each row, the perforations shall be located on the inside crests of all corrugations. Perforations are not required within 4 inches of the ends of each length of pipe or in the corrugations where seams are located. The perforations shall have a diameter of not less than 1/4 inch nor more than 3/8 inch. The number of rows of perforations and the width of unperforated bottom segment shall be as follows:

<u>Inside Culvert Diameter (inches)</u>	<u>Number of Rows</u>	<u>Minimum Width of Unperforated Bottom Segment (inches)</u>
6	4	4.5
8	4	7.0
10	4	9.0
12	6	9.5
15	6	13.0
18	6	16.5
21	6	20.0
24	8	22.0



2.2 WASHED ROCK

Angular or rounded, 1/4 to 1-1/2-inch, graded stone, or acceptable local materials such as coral, slag, cinders, crushed stone and crushed shells.

PART 3 EXECUTION

3.1 CULVERT INSTALLATION

- A. Excavation: Trenches shall be excavated to a width sufficient to allow for proper jointing of the culvert and thorough compaction of the bedding and backfill under and around the culvert.
- B. Culvert Placement:
1. Unperforated Culverts: All culverts shall be installed on a smooth and uniform foundation. Abrupt changes from hard to soft foundation should be avoided. A minimum of 6 inches of well-graded, granular material is to be placed beneath any pipe installed on a soft foundation. Hard or rock foundations are to be over-excavated a minimum of 6 inches and a well-graded, granular backfill or other suitable material installed to the proper grade and to the required density. All culvert installations are to be made in dewatered conditions.
 2. Perforated Culverts/Underdrains: All culverts shall be perforated as specified above. Prior to culvert placement, a drainage fabric shall be laid in the trench to separate the washed rock from the trench bottom and walls. See Geotextiles, Section 2242. The fabric shall be of adequate width to cover the top of the washed rock with a 2-foot overlap. A minimum of 4 inches of washed rock is to be placed beneath the culvert.
 3. High Density Polyethylene Pipe: Installation shall be in accordance with ASTM D2321 and in accordance with manufacturer's recommendations.
- C. Connections:
1. Concrete pipe: Concrete pipe sections shall be joined in such a manner that the ends are fully entered and the inner surfaces are reasonably flush and even. Joints shall be made with pipe joint sealing compound unless otherwise directed by the Engineer.
 2. Corrugated metal pipe: All connections shall be made with the proper sized band as supplied by the manufacturer.
 3. Where aluminum drainage pipe is to be in contact with steel structures or components, contact areas shall be given a heavy bituminous coating, inside and out, for a distance of 12 inches beyond the contact, or bituminous-coated coupling bands shall be used.
- D. Backfill:
1. Unperforated Culverts: Backfill material should preferably be granular; however, cohesive type material can also be used if careful attention is given to compaction at or very near optimum moisture content. All backfill material is to be compacted to 95 percent of maximum density.

Backfill around the pipe and under the haunches shall be placed alternately in 6-inch lifts. The elevation of the backfill on either side of the pipe is to be kept nearly equal at all times during the backfilling process. For the installation of the pipe arches, the material beneath the corners is to be compacted to 100 percent maximum density. Mechanical compaction is to be done by means approved by the Engineer. Hydraulic backfilling will not be permitted.



For pipe arches, the backfill is to be placed around and over the structure in uniform layers, conforming to the slope of the arch and thoroughly compacted. When backfilling arches without headwalls, the first fill is to be placed midway between the ends of the arch.

- 2. Perforated Culverts/Underdrains: The culvert shall be backfilled with washed rock to a minimum of 4 inches above the culvert. The washed rock shall be covered with the drainage fabric. Backfill above the fabric shall consist of suitable native material. If suitable native material is not available, pit run material shall be imported for backfill. The washed rock placed shall be compacted with a vibratory plate. Other backfill material shall be compacted to 95% of maximum density.
 - 3. Paved Areas: In existing pavement areas, allowance shall be made for a minimum of 4 inches of road base material and a 4-inch asphalt patch.
- E. Minimum cover: Minimum cover shall be measured from the top of the pipe to the finished subgrade. Minimum cover of culverts shall be 12 inches for the following types and sizes unless waived by the Engineer.

Corrugated Steel:

- a. Circular Up to 96" diameter
- b. Arch Up to 84" equivalent diameter

Corrugated Aluminum:

- a. Circular Up to 72" diameter
- b. Arch Up to 60" equivalent diameter

Concrete:

All sizes

High Density Polyethylene

Per Manuf. Recommendations

Minimum cover for High Density Polyethylene for areas receiving regular traffic shall be 12 inches. Minimum cover for construction traffic shall be 2 or 3 feet depending on weight of vehicles.

Minimum cover for sizes larger than those shown and maximum fill heights for all culverts shall be per the manufacturer's recommendation and subject to approval by the Engineer.

3.2 FIELD QUALITY CONTROL

Maximum density and optimum moisture content shall be as determined by ASTM D 1557, Modified Proctor.

PART 4 MEASUREMENT AND PAYMENT

4.1 CULVERTS

Payment for culverts shall be on a per installed linear foot basis and shall include the cost of the pipe, bends, bands, excavation, backfill, washed rock and fabric as required. Additional payment shall be made on a cubic yard basis for imported backfill material, imported road base and off-site disposal of excess or waste material. Payment for end sections shall be per end section installed. Payment for asphalt patching shall be made per the appropriate Bid item.



SECTION 2523 MANHOLES

PART 1 GENERAL

1.1 DESCRIPTION

Work included: Manholes, for sanitary sewers, storm sewers, water system specialty valves or meters, and other installations when specifically called out.

1.2 QUALITY ASSURANCE

Work shall meet current Colorado Department of Public Health and Environment, CDPHE, requirements in installations for sanitary sewer, or potable water systems, and the most current edition of Standard Specifications for Road and Bridge Construction, CDOT, State of Colorado requirements for storm sewer applications.

The Contractor shall guaranty all water and sanitary sewer manholes to be leak free for one year from the date of preliminary acceptance of the entire project, or for two years if the Owner elects to require an extended warranty because of low spring runoff conditions.

1.3 SUBMITTALS/SUBSTITUTIONS

Submittals are required for the work in this section unless waived by the Engineer. If the Contractor proposes not to provide submittals on portions of this work the Contractor must submit a "clarification request" formally requesting a waiver.

1.4 PRODUCT DELIVERY, STORAGE AND HANDLING

Precast units shall be carefully handled and stored so that the concrete does not crack and the joints are not damaged. Broken joints and cracked concrete shall be cause for rejection.

PART 2 PRODUCTS

MATERIALS

Manholes:

1. Concrete: Per ASTM C 478. 4,000 psi with a minimum of 470 lbs of Type II Portland Cement per cubic yard of concrete, and a water cement ratio not to exceed 0.53.
2. Base, Riser, and Conical Top Sections: Per ASTM C 478. The conical top section shall have a 24-inch diameter access opening at its top. The base, riser, and bottom of the conical top section shall be 48 inch inside diameter unless called out otherwise on the plans or in the Special Provisions. Pre-cast base slabs or floors shall have a minimum thickness of 6 inches for 48-inch diameter risers and 8 inches for larger diameter risers.
3. Flat Slab Tops: Per ASTM C 478. Access opening shall be 24-inch diameter. The minimum slab thickness shall be 6" for manholes up to 48" in diameter, and 8" for larger diameters. Design for H-20 live load, and dead load based upon the amount and type of fill to be placed on the slab and the weight of the riser supported by the slab.
4. Grade Rings: Precast concrete. Per ASTM C 478.



5. Joints and Joint Sealant:

- a. Joints manhole sections to include pre-cast base, riser, conical sections, flat slab tops, and grade rings.

Per ASTM C-478 made with male and female ends and sealed with RUB'R-NEK or equal flexible gasket-type sealant of partially vulcanized butyl rubber per Federal Specification SS-S-210A. Two gaskets are required per joint. Gasket size shall be as recommended by the manufacturer based upon the annular space to be sealed. If the minimum cross-sectional area equivalent of the gasket is less than one-inch diameter, confirm suitability with Engineer before proceeding.

- b. Joint between cast-in-place base and riser.

Flat bottom riser placed on a flat formed base and sealed with two flexible gaskets per a. above.

- c. Pipe to Manhole Seal

- 1) Pre-cast Base: Flexible rubber boot in a cored hole per ASTM C 923. Connectors shall be KOR-N-SEAL, A-LOK or approved equal.
- 2) Cast-in-place Base: Sealed with two elastomeric seals minimum per pipe, (o-ring water stops) per ASTM F 477.

- d. Joint between the cast iron frame and concrete surfaces.

RUB'R-NEK or equal flexible gasket-type sealant of partially vulcanized butyl rubber per Federal Specification SS-S-210A. One gasket with a minimum cross-sectional area equivalent to one inch in diameter is required per joint.

6. Steps: Per ASTM C 478 modified as follows. Type PS1-PF ½-inch diameter Grade 60 steel reinforcing rod completely encapsulated in Copolymer Polypropylene as manufactured by M.A. Industries, Inc. The step shall be installed so that the distance from the wall of the riser or cone, measured from the point of embedment to the outside face of the rung is 6 inches. The distance from the top of the final cover elevation to the first step shall be 24 to 26 inches. There shall be a uniform distance between steps including the bench. Maximum spacing shall be 16". Steps must be capable of carrying a load of 1,000 pounds when projected six inches from the wall without causing permanent deformation.

7. Frames and Lids (Rings and Covers): Heavy duty castings, designed for H-20 traffic loading, of gray cast iron per ASTM A 48 of uniform quality, free from cracks, holes, swells, and cold shuts, and having a smooth workman like finish. Castings, Inc., catalogue No. MH 400-24-CI, or equal, 410 lb., 8-inch frame with solid lid and one pick opening. Inverted frames shall be Castings, Inc., catalogue IMH 250-24-CI, or equal. The 3/4" pick opening is required. All metal bearing surfaces between the ring and cover will be machined or fabricated to insure good seating.

Lids shall be lettered "SEWER" or "WATER" depending upon application.

8. Adjusting Rings (Extension Rings): Gray cast iron, ASTM A48, Class 25, Castings, Inc., or equal to match lid opening.
9. Exterior coating: THOROSEAL Foundation Coating or equal.
10. Grout: Non-shrink, non-metallic either cement or epoxy based as recommended by the manufacturer for the application.



11. Mortar: Masonry cement per ASTM C91. Aggregate per AASHTO M 45. Proportion by volume shall be one-part masonry cement to three parts aggregate (maximum).

PART 3 EXECUTION

3.1 GENERAL

Manholes shall be installed level and plumb. All Steps shall be set such that they are centered above the manhole bench and not the pipeline inverts.

3.2 INSTALLATION

A. Bases:

1. Pre-cast Bases: Install pre-cast bases unless specific connection requirements dictate a cast-in-place structure.
2. Cast-in place Bases: The use of cast-in-place bases must be authorized by the Engineer prior to installation.

Cure cast-in-place bases for a minimum of 24 hours at no less than 40 degrees F prior to placement of pre-cast rings. Provide insulation for curing whenever the temperature is less than 45 degrees.

- #### B. Inverts: Invert channels are required in all sanitary sewer manholes unless called out otherwise on the Drawings or in the Special Provisions. Invert channels are not required in storm sewer applications unless called out otherwise on the Drawings or in the Special Provisions.

Where invert channels are required, they shall be smooth and semi-circular in shape conforming to the inside of the incoming and outgoing lines. Changes in the direction of flow shall be made with a smooth curve of as large a radius as the size of manhole will permit. Changes in size and elevation shall be made with smooth, uniform transitions. Dept of inverts $\frac{1}{2}$ diameter, $\frac{3}{4}$; or full will be called out in Special Provisions or on Drawings.

Inverts for pre-cast bases may be formed monolithically with the base section. Deflecting pipes to meet inlet and outlet openings in manholes will not be permitted.

- #### C. Stub-outs for future connections: Stub-outs shall consist of a section of the specified sewer pipe with bell end. The end of the stub shall extend 6 inches beyond the outside edge of the manhole base, and shall be plugged with a manufactured watertight plug compatible with the stub-out pipe used. The stub-out shall be bedded in and fully supported with imported bedding material.
- #### D. Flat Slab Tops: Substitute a riser section and flat slab top for the cone section in all manholes where the vertical distance between the top of the cone section and invert is 5 feet or less.
- #### E. Grade Rings: A maximum of 12 vertical inches of grade rings may be installed to bring the frame and lid to final elevation.



F. Frames and Lids (Rings and Covers):

1. Paved areas:

Frames and lids shall be installed to match the slope of paved areas by shimming the grade rings with mortar. Where no grade rings are installed shimming with mortar between the top section and frame will be permitted.

A 2-inch adjusting ring is required between the frame and lid in all paved areas.

Set the lid 1/2 inch below the pavement surface.

2. Gravel areas:

Frames and lids shall be installed plumb and level.

Set the lid 2 to 4 inches below the gravel surface.

3. Gravel areas to be paved:

Frames and lids shall be installed to match the slope of the future pavement.

Set the lid 2 inches below the gravel surface.

4. Open fields or places other than paved or graveled areas:

Final grade shall be as shown on the Drawings, or stated in the Special Provisions. If the final grade is not indicated submit a clarification request to the Engineer for establishment of the final grade.

5. General:

The Contractor shall make all adjustments to manholes necessary to achieve the above requirements in phased construction where traffic or plowing will be allowed on the partially completed work.

G. Sealing: Manholes for water and sanitary sewer systems shall be watertight. All necessary precautions shall be taken to assure that water will not infiltrate into the manhole. All visible running leaks shall be permanently sealed.

The joints between sections to include the base, riser, conical top section and flat slab top shall be sealed with flexible joint sealant.

In pre-cast bases, pipe to manhole connections shall be sealed with a flexible rubber boot per the manufacturer's instructions.

In cast-in-place bases, pipe to manhole connections shall be sealed with two O ring water stops.

In connections to existing manholes where it is necessary to break into the manhole, the pipe to manhole connection shall be sealed with two O ring water stops as in cast-in-place bases and the annular space shall be grouted water tight per the manufacturer's instructions. All holes placed in existing manholes shall be made by coring or by the drilling of multiple holes around the perimeter of the proposed hole and then breaking-out the hole. The use of jackhammers shall not be permitted. A one-year warranty shall be applied to all existing manholes that are modified by the Contractor as part of the project.

Grade rings shall be installed in a bed of mortar. Joints between grade rings and between grade rings and other components shall be pointed with mortar to a smooth finish inside and out.



Joints between cast iron frames and concrete surfaces shall be sealed with flexible joint sealant.

Install one coat of exterior coating on the outside of all buried concrete surfaces in accordance with the manufacturer's instructions. The application rate shall be 2 lbs per square yard of surface area coated.

Install waterproof lids in all locations noted on the Drawings or called out in the Special Provisions.

- H. Pavement Transitions: When a manhole is located partially within a paved area or is located totally within a paved area but is less than one foot away from the pavement edge, the pavement shall be widened to extend around the manhole cover a minimum of 1 foot with a 20-foot transition to normal pavement width on either side. In each case the Contractor shall coordinate with the Engineer prior to installing manhole covers partially within a paved area and prior to constructing the pavement transition to clarify exactly how to proceed.
- I. Drop Manholes: Drop manholes shall be outside drops constructed as shown on the Drawings. An in-line wye fitting shall be provided to initiate the drop. Additional bends may be necessary along the drop to provide proper drop alignment.

All fittings shall be securely anchored to prevent movement during placement of concrete around the drop.

Drop manhole locations shall be identified on the Drawings or may be required by the Engineer to facilitate field changes in grade or alignment.

- J. Follow up Inspection/Extended Warrantee: All manholes for water or sanitary sewer systems will be inspected for leakage by the public entity responsible for maintaining the sewer system during spring runoff in the year following installation. All leaks or other defects noted during the inspection will be corrected under the Contractor's warranty. The Contractor shall provide personnel necessary to assist in these inspections if requested by the Owner or public entity.

In the event that an abnormally dry winter occurs resulting in low spring runoff and a low groundwater table, the public entity at its sole option may elect to re-inspect the manholes for leakage the next following spring. The public entity will notify the Contractor of its decision to re-inspect the manholes for leakage prior to the end of the normal one-year warranty period. The Contractor shall automatically extend his warranty for leak free manholes for one additional year at no additional expense to Owner or public entity upon receipt of the public entity's notice.

PART 4 MEASUREMENT AND PAYMENT

4.1 MANHOLES

- A. Manholes will be measured and paid for at the Unit Price per Each under the item Manholes per diameter up to 8 feet depth. The depth of a manhole is measured from the highest point of the cover to the lowest pipe invert.
- B. Extra Depth at manholes shall be measured and paid for at the Unit Price per Vertical Foot in excess of 8 feet depth under the item Extra Depth at Manholes per manhole diameter.
- C. Drop Manholes will be measured and paid for at the Lump Sum Price under the Drop Manhole item per specific manhole.



4.2 GENERAL

The prices for the above items shall include the cost of excavation (excluding rock excavation), native backfill, support system, imported foundation and bedding shown or specified as part of the standard installation, stub-outs, dewatering, flushing, testing and inspection, and the cost of all materials, equipment, tools and labor incidental or necessary for completion of the work.

No measurement or separate payment will be made for alterations to existing manholes required to make pipe connections, the cost shall be considered incidental to the Work.



SECTION 2555
WATER DISTRIBUTION PIPING AND APPURTENANCES

PART 1 GENERAL

1.1 DESCRIPTION

Work included: Water distribution piping, valves, fittings, and other related appurtenances to include flushing, testing, and disinfection.

1.2 QUALITY ASSURANCE

- A. Installation shall meet current Colorado Department of Public Health and Environment, CDPHE requirements and shall be suitable for conveying potable water under pressure.
- B. Installation of Ductile Iron and PVC water mains shall conform to ANSI/AWWA C600.

1.3 SUBMITTALS/SUBSTITUTIONS

- A. No substitutes will be considered for items listed by manufacturer's name and/or model number in this section unless the words "or equal" are included as a part of the description.
- B. Submittals are required for all proposed substitutions and all items not specifically listed by manufacturer's name and model number.
- C. A certification is required for all buried bolts.

1.4 PRODUCT DELIVERY, STORAGE AND HANDLING

- A. All Material: Comply with AWWA C 600 and as follows. Slings, hooks, or pipe tongs shall be padded and used in such a manner as to prevent damage to the exterior surface or internal lining of the pipe. Under no circumstances shall any materials be dropped. Valves and hydrants shall be drained and stored in a manner that will protect them from damage by freezing. The interior of all pipe, fittings, and other appurtenances shall be kept free from dirt or foreign matter at all times.

Pipe may be stacked per the manufacturer's recommendations but shall not be stacked higher than five feet. In distributing material at the work site do not interfere with access to private property, parking or traffic. Stockpile materials as close to the installation site as feasible. It is recommended that only as much pipe as can be used during the day is strung out along the work site.

- B. PVC Material: PVC materials shall not be stored in direct sunlight for prolonged periods. Covering with an opaque material may be necessary. Since scratches and cuts decrease the pressure rating of PVC pipe, excessive cuts, scratches or abrasions, etc. shall be grounds for rejection of the material. The Contractor is urged to take precautions to avoid abrading or cutting the pipe.
- C. Gaskets for mechanical and push-on joints to shall be placed in a cool location out of direct sunlight. Gaskets shall not come in direct contact with petroleum products. Gaskets shall be used on a first-in, first-out basis.
- D. Damaged Material: All such material shall be rejected and removed from the job site immediately.



1.5 JOB CONDITIONS

- A. Weather: Weather protection, temporary heating, and snow removal shall be the Contractor's responsibility. Particular restrictions shall apply to the installation of PVC water pipe during winter conditions. Such installations will not be allowed when weather conditions will not permit high quality construction.
- B. Temperature:
 - 1. Absolutely no work shall be allowed on the pipelaying portion of the project at temperatures below 20 °F.
 - 2. No work shall be allowed on the pipelaying portion of the project on any day when the 10:00 a.m. temperature is below 30 °F.
 - 3. A succession of three consecutive days with the 10:00 a.m. temperature below 30 °F shall be grounds for shutting down the pipelaying portion of the project. Resumption of work on the pipelaying portion of the project will be allowed after three consecutive days with the 10:00 a.m. temperature above 30 °F provided there is no frozen backfill or bedding material.
 - 4. Contractor shall coordinate with the Engineer when temperatures approach the conditions for shut down of the pipe laying operations. Contractor may institute suitable protective measures to continue work if authorized by the Engineer.

PART 2 PRODUCTS

2.1 MATERIALS

A. Ductile Iron Pipe:

- 1. Pipe: ANSI/AWWA C151/A21.51, DIP Pressure Class 350 ANSI/AWWA C150/A21.50
- 2. Cement lining: ANSI/AWWA C104/A21.4
- 3. Push-On or Mechanical joints: ANSI/AWWA C111/A21.11
- 4. Wall thickness: Class 50 for 12-inch diameter or less.
- 5. Conductivity: by serrated brass wedges, "Cadweld" connections, or welded/bolted copper strip conductors.
- 6. Tee bolts: low alloy steel (Cor-ten or equal).
- 7. Pipe Joint Lubricant as recommended or supplied by the manufacturer.

B. Polyvinyl Chloride (PVC) Pressure Pipe:

- 1. Pipe and joints: ANSI/AWWA C-900 DR-14 (305 PSI) for 4-inch through 12-inch diameters and ANSI/AWWA C900 DR-25 (165 PSI) for the tank drain line and ANSI/AWWA C905 DR 18 (235 PSI) for sizes 14-inch through 24-inch diameter.
- 2. Joints: integral wall-thickened bell end or gasketed coupling using elastometric gaskets conforming to ASTM F 477 and meeting performance requirements of ASTM D 3139.
- 3. Wall Thickness: DR-14 (305 PSI) for sizes 4-inch through 12-inch diameters with DR-25 (165 PSI) for the tank drain line, and DR-18 (235 PSI) for size 14-inch through 24-inch diameter. Pipe Joint Lubricant as recommended or supplied by the manufacturer.

C. Fittings: shall be mechanical joint and employ a Megalug follower gland unless specifically noted as flange joint for a particular fitting.

- 1. Ductile Iron and Cast Iron: ANSI/AWWA C110/A21.10, 250-psi min pressure rating.
- 2. Ductile Iron Compact Type: ANSI/AWWA C153/A21.53, 350 psi pressure rating.
- 3. Coating and Lining Fusion Bonded Epoxy: ANSI/AWWA C116/A21.16
- 4. Mechanical joint: ANSI/AWWA C111/A21.11
- 5. Flange joint: ANSI/AWWA C115/A21.15
- 6. Swivel Fitting: per Tyler Pipe or equal.



7. Sleeves: mechanical joint long solid sleeves.
8. Tee bolts: low alloy steel (Cor-ten or equal).
9. Flange bolts: Type 304 stainless steel A 193 grade B8. All bolts shall employ a washer between the flange and nut. All bolt threads and washer shall be coated with C5A copper based anti-seize.
10. Pipe Joint Lubricant as recommended or supplied by the manufacturer.
11. Tapping Sleeve: Ductile iron, mechanical joint by flange, split tee type with a working pressure of 200 psi and compatible with the tapping valve. Gaskets shall be totally confined and correctly sized for the outside diameter of the pipe being tapped.
Stainless Steel Tapping Sleeve: ROMAC Industries Model SST or approved equal. Working pressure 200PSI. Size on size not allowed for SS tapping sleeve.
12. ALL FLANGES INCLUDING TAPPING SLEEVE. 'Full Face Flange-Tyte Gasket' with (3) bulb type rings by US PIPE. www.uspipe.com, BRO-023_ Submittal.

D. Valves and Appurtenances: Valves shall be epoxy coated.

1. Gate valves (3 inches thru 12 inches): AWWA C 515-01; non- rising stem, open left, with 2-inch square operating nut, rated for 200 PSI working pressure, Mueller 2360 series resilient wedge gate valves. Bolts to be Type 304 stainless steel A 193 grade B8 with C5A anti-seize on the threads. Tee bolts shall be COR-TEN per ASTM 242.
2. Tapping Valve: Per gate valves this section, Waterous 2500 or Mueller T-2360 series.
3. Butterfly Valves: All valves over 12-inch diameter AWWA C 504; short body. Manual operator, open left, replaceable seat, with 2-inch operating nut, rated for 150 PSI working pressure. Mueller Linseal or Waterous 700. Bolts to be per Gate Valves this section.
4. Combination Air Valve: All combination air and vacuum release valves shall be in accordance with AWWA C512 and shop assembled and shipped as a complete unit ready for field installation. The valve shall be the single body type: APCO 145C with 2" inlet/outlet pipe thread.
5. Valve boxes and extensions: shall be screw-type Tyler Pipe Series 6850 or equal. Adjustable to 8-foot depth of cover.
6. Valve Operator Nut Riser: Risers shall be 7/8-inch solid bar stock with welded square base to fit over a 2-inch standard valve nut. Provide a centering plate and a standard 2-inch Valve Operator Nut welded to the top end of the bar.

E. Fire Hydrants and Appurtenances:

Hydrant: Per AWWA C 502; with 6-inch mechanical joint pipe connection, automatic drain feature (drip valve), open left, 1-1/2-inch pentagonal operating nut, two 2-1/2-inch National Standard (NST) thread hose nozzles, and a 4-1/2 inch NST thread steamer nozzle, YELLOW in color. Hydrant bury, which refers to the distance from the ground line to the bottom of the hydrant lateral shall be compatible with the depth of cover specified. Typical 7-6" Bury. Hydrant shall be Kennedy Guardian K81D dry barrel with 34-inch top. All buried bolts shall be type 304 stainless steel A 193 grade B 8 or equal.

F. Service Lines and Appurtenances:

1. All Brass shall be Lead-Free Ford Water Works Brass. Pack Joint, Grip Joint or Quick Joint for copper or plastic tube (CST) with Buna-N Gaskets. Inlet, outlet and valve size shall be identical.
2. Service lines shall be Type K, seamless soft copper tubing unless indicated otherwise on the Drawings.
3. Corporation stops Ford, FB-1000 NL Ballcorp - AWWA/CC inlet by Pack Joint outlet or equal.
4. Curb stops Ford, B44-NL Ball Curb Valve or equal.
5. Couplings Ford Pack Joint C44-NL or equal.



6. Curb boxes: McDonald 5607 or equal with a 1-inch diameter upper shaft, 7-1/2-foot box, arch base, plug style lid and stationary rod extending to 1 foot of the surface. Where necessary, an enlarged base shall be supplied with large curb stops.
 7. Tapping saddles shall be Ford Brass, Double Strap 202B-xxx-ccx brass saddles of the appropriate dimension to be compatible with the size main to be tapped and the size of tap required. Gaskets shall be Buna-N.
 8. Polyethylene Tubing shall be AWWA C901-96, Polyethylene tubing, CTS, PET, CL 200, connections shall use insert stiffeners sized properly for each tube size and type of fitting. Polyethylene tubing shall be used where specifically indicated on the drawings.
 9. Detection Wire: A10 gauge solid 45-MIL Blue Polyethylene coated insulated detection wire. All splices shall be made with watertight connections (Crimp connections, Dielectric compound and heat shrink sleeves).
- G. Restrained Joints: Bolts and all thread rod or tie bars shall be Cor-ten Steel.
1. DIP: shall be Megalug Series 1100, Series 1100 SD Split Megalug, Series 1100 HD Megalug Harness or Series 1700 Bell Harness by EBBA Iron, Inc.
 2. PVC: shall be Megalug Series 1500, or Series 2000 PV by EBBA Iron, Inc.
- H. Encasements and Thrust Blocks:
1. Concrete: shall be a minimum 3000 psi compressive strength, 6 sacks per cubic yard, Type II Portland Cement.
 2. Reinforcing steel: Grade 40, ASTM A615.
- I. Stub Markers: New 4x4 green treated timber for buried installation. Length shall be as required to extend from designated grade to the water main stub.
- J. Water Marker Posts shall be blue Carsonite utility marker with water decal 112-CW, Model CUM-375, CRM 307208 (72" length) by Carsonite International.
- K. Polyethylene Encasement: Per AWWA C 105.
- L. Tracer Wire: Shall be #10 solid copper wire coated with 45 MIL Blue Polyethylene. Use Underground Waterproof Splice Kits: 3M DBR or equal. THHN wire is not acceptable as tracer wire.
- M. Tracer Wire Test Station: Required at all fire hydrants or other locations as specified by the Engineer. Model "Glenn Test Station" by VALVCO, Inc.

PART 3 EXECUTION

3.1 PIPE INSTALLATION

- A. General: Comply with the manufacturer's recommendations and ANSI/AWWA C 600.

Polyethylene Encasement: AWWA C 105 shall cover all DIP water main, valves, fittings, restraint devices, services from the main three feet outward, and hydrant barrels to the bury line.

Materials shall not be dropped into the trench but shall be lowered by hand or machine. Blocking under the pipe shall not be used.

The interior of all pipe and fittings shall be kept in a clean, sanitary condition at all times. During pipe-laying operations, no debris, tools, clothing or other material shall be placed in the pipe. Any foreign material found in the pipe shall be removed prior to joining. When pipe-laying operations are not being conducted, all pipe openings are to be plugged with a watertight plug.



All lumps, blisters and excess coal-tar coating on ductile iron pipe shall be removed from the bell-and-spigot end of each pipe, and the outside of the spigot and the inside of the bell shall be wire-brushed and wiped clean and dry and free from soil and grease before the pipe is laid.

After placing a length of pipe in the trench, the spigot end shall be centered in the bell, lubricated and the pipe forced home and brought to correct line and grade. Precautions shall be taken to prevent dirt from entering the joint space.

The cutting of pipe for inserting valves, fittings, or closure pieces shall be done in a neat and workmanlike manner leaving a smooth end at right angles to the axis of the pipe. Pipe cutting shall be done without damaging the remainder of the pipe or the cement lining. The flame cutting of DIP by means of an oxyacetylene torch shall not be allowed. The cut end shall be beveled to the manufacturer's specifications to allow the pipe to be joined without damage to or displacement of the rubber gasket. PVC pipe to be inserted into a mechanical joint shall be square cut and not beveled or have a factory bevel. The spigot end of all push joints shall be lubricated to the stab line. Gaskets and Mechanical Joints shall be lubricated per the manufacturer's recommendations. Mechanical joints shall be lubricated during assembly.

Wherever it is necessary to deflect the pipe from a straight line, either in the vertical or horizontal plane, the allowable amount of deflection shall be that indicated in the following Section.

The standard depth of cover from finished grade for water mains shall be 7-feet. All appurtenances shall be compatible with a 7-foot depth of cover if not so specified. In areas where water mains are to be installed in conjunction with road construction or over lot grading, the rough subgrade shall be constructed prior to installing the water mains or service lines.

Cover depths greater than 8 feet shall not be permitted without prior approval from the Engineer, Town or Owner.

B. Deflection or Curvature: Refer to Manufacturer's Recommendations

1. Ductile Iron, Push-on joints & Mechanical Joints:

<u>Allowable Deflection per Joint</u>		
<u>Diameter (inches)</u>	<u>Minimum Radius of Curvature (feet)</u>	<u>Deflection per 18' Length (inches)</u>
4, 6, 8, 10, 12	205	16
Greater than 12: Refer to Manufacturer's Recommendations		

2. PVC Pipe: The trench may be curved to change direction or avoid obstructions within the limits of curvature of the pipe as the manufacturer recommends. The manufacturer may allow curvature in the joints. If curvature is only allowed in the pipe only with no deflection allowed in the joint, deflection couplings may be used at joints if additional curvature is necessary.

<u>Diameter (Inches)</u>	<u>Minimum Radius of Curvature (feet)</u>	<u>Deflection per 20' Offset force (lbs.)</u>	<u>Deflection per 20' Length (inches)</u>
4	100	30	24
6	144	80	17
8	189	170	12
10	231	370	11
12	275	560	9

Mechanical means shall not be used to accomplish the radii of deflection, but rather by hand in the trench.



C. Electrical Conductivity:

1. Ductile iron pipe: Install brass wedges on all push-on joints and mechanical joints to provide electrical conductivity, 2 equally spaced per joint for 12-inch diameter pipe and smaller, and 4 equally spaced per joint for greater than 12-inch diameter pipe. "Cadweld" connections, or welded/bolted copper strip conductors installed per the manufacturer's recommendations may be substituted for brass wedges.
2. Polyvinyl Chloride (PVC) pipe: There is no conductivity requirement for PVC mains. PVC mains shall have a detection wire installed with the pipe and it shall extend to the surface at hydrants and outside valve boxes and as directed. The wire will be tested for continuity and accessibility.

D. Thrust Restraint:

All mains shall use Restrained Joint Thrust Restraint except for lines serviced by the Airport Pump Station, which shall be restrained with thrust blocks in addition to restrained joints and both shall be designed for the working pressure of the system. All plugs, caps, tees, bends and hydrants shall be restrained to resist vertical and horizontal thrust blocked as required to resist vertical and horizontal reactions.

The thrust block shall extend from the fitting, valve or hydrant to solid undisturbed earth. Form sides of thrust blocks on line sizes greater than 8" diameter. Thrust blocks shall be installed so all joints are accessible and the concrete does not come in contact with the joint bolts. Concrete shall cure a minimum of 24 hours at no less than 40 degrees F prior to backfilling. Do not apply internal water pressure to any section of pipe containing concrete thrust blocks until the concrete has cured for at least 48 hours.

Where undisturbed trench walls are not available for thrust blocking, the Contractor shall make other provisions for thrust restraint subject to the Engineer's review.

All joints on 6-inch pipe hydrant laterals shall be fitted with joint restraint devices.

All other fittings shall be restrained per the tables at the end of this section.

Any unlisted fittings and any new Pressure Zones shall be individually calculated.

F. Reinforced Concrete Encasements: shall be constructed as shown on the Drawings or described elsewhere in the Specifications.

Prior to placing the concrete temporary supports consisting of concrete blocks or bricks shall be used to support the pipe in place. Not more than two supports shall be used for each pipe length, one adjacent to the shoulder of the bell and the other near the spigot end.

No reinforced concrete encasements shall be poured until the Engineer has inspected the pipe to be encased, reinforcement, and supports. The encasement shall cure a minimum of 24 hours at no less the 40 F° prior to backfilling.

G. Stub Markers: Shall be installed at all water main stubs for future service. The markers shall extend from finished grade to the stub in open areas, and shall extend from subgrade to the stub in roadways.

H. Water Marker Posts shall be installed at all water main stubs for future service, all valves, curb valves and water structures out side the traveled way. The markers shall extend from finished grade 2.5' below ground and shall be plumb and faced in a consistent direction.



3.2 INSTALLATION OF FIRE HYDRANTS

- A. Hydrants shall be installed per the manufacturers recommendations with a thrust and bearing block, stand plumb, with pumper outlets facing in the direction in which a fire department vehicle will logically be located and 2 feet into the street right-of-way from the property line.
- B. Each hydrant connection shall have a gate valve and valve box located on the hydrant lateral. The hydrant lateral shall be connected to the main with a 6-inch diameter pipe. The placement of the valve on the hydrant lateral shall be as shown on the Drawings or designated in the Special Provisions.
- C. The use of swivel fittings on hydrant laterals for aiding in meeting grade requirements is acceptable.
- D. Normally all hydrants shall be provided with drainage weep holes. If during construction, high groundwater is encountered in the location of the hydrant, the Engineer may direct the Contractor to plug the weep holes and convert it to wet-barrel hydrant. This shall be accomplished by threading a plug into the weep holes or by some other method approved by the Engineer. Hydrants so converted shall have the top cap of the hydrant painted with rust inhibiting red paint.

Hydrant drainage shall be provided by a drainage pit at least 3 feet in diameter and 3 feet deep excavated below the hydrant and filled with $\frac{3}{4}$ inch washed rock bedding material under and around the elbow of the hydrant and to a level of at least 6 inches above the waste opening. A minimum of 1 cubic yard of bedding material shall be used.

- E. If upon final installation of the hydrant it needs to be raised to obtain the proper ground clearance, the Contractor shall raise the hydrant to the proper level by means of an appropriate hydrant extension kit.

3.3 GATE VALVE AND BOX INSTALLATION

- A. General: Valves shall have their interior cleaned of all foreign matter and shall be inspected in opened and closed positions before installation to insure that all parts are in working condition. Set the valve box centered and plumb over the valve-operator nut.
- B. Grade: The Contractor shall be responsible for adjusting the final height of all new valve boxes and curb boxes to the levels specified or as directed by the Owner or Town. The valve boxes shall be set to the following grades:

Paved streets	$\frac{1}{4}$ -1" below grade
Gravel roads, shoulders & driveways	2-4" below grade
Areas not in road easements or affected by snow plowing operations.	Set flush to grade

- C. Valve Operator Nut Riser: Valve operator nut risers shall be provided on all valves to bring the operating nut to within 2 feet of finished grade.
- D. Valve Anchor: All valves on PVC mains greater than 3 inch in diameter shall be installed on, and tied to, a concrete anchor capable of resisting all thrusts. Valve anchors shall be per the Drawings.

3.4 SERVICE LINES

- A. Size: No service line shall be less than 3/4-inch diameter. All service lines shall be in conformance with the current Uniform Plumbing Code (UPC) to adequately supply the property being served.



When connecting to existing service lines the Contractor shall notify the Town of all line sizes encountered larger than 3/4-inch diameter, which were not indicated on the Drawings prior to connecting the new service.

- B. Installation of Service: Water service line construction in streets or rights-of-way shall be done in compliance with all pertinent City, County or State ordinances.

Curb stops shall be installed so that the "open" position is perpendicular to the direction of the main line and in line with the service line.

- C. Taps: No taps for services shall be made prior to the main being tested and approved. Make all taps to a live, pressurized main. The minimum separation between a service line tap and valves, fittings or another service tap shall be 10 feet unless authorized otherwise by the Engineer.
- D. Depth of Service Lines: All services shall be installed to a minimum depth of 7 feet as measured from the top of the pipe to finished grade.
- E. Inspection: The Engineer shall inspect all water services prior to backfilling and use.
- F. Location: All service line locations are subject to review and approval by the Town. Service lines shall be laid in a continuous straight line, perpendicular to the main whenever possible. All services shall be a minimum of 5 feet from any lot or property corner. In general, curb stops and boxes are to be placed at the property line.
- G. Separate Trenches: All domestic water services shall be laid so that no point is nearer than 10 lateral feet from a sewage service line, sewer main, building drain, any waste discharge line or non-potable water line.
- H. Curb Box Elevation: The top of the curb box shall be located 12 inches above grade in non-traffic areas, 4 inches below grade in traffic areas or as directed by the Town or Owner.
- I. All service taps shall be made with a tapping saddle.
- J. Polyethylene Services shall have a Detection Wire. A 10-gauge solid THHN insulated detection wire shall be placed on the top of the polyethylene water service. All splices shall be made with watertight connections. The locator wire shall be electrically connected at the valve box on each end. The contractor shall demonstrate the function of the locator wire.

3.5 TAPPING SLEEVE AND VALVE (LIVE TIE)

A test hole may be required to confirm existing pipe size, material and location prior to ordering live tie materials.

A Contractor experienced and specializing in live ties shall make live ties. If a Contractor desires to rent the necessary equipment from a tapping sleeve manufacturer, he shall also arrange for a factory trained instructor to be present to supervise the initial installation and provide the necessary training of Contractor personnel. The Contractor shall receive the Town's approval for all live tie procedures prior to commencing the work.

Tapping sleeves shall be assembled and tested per manufacturer's directions. Tapping sleeves shall be well supported independently of the pipe. All operation of tapping equipment and tapping procedures shall be in accordance with manufacturer's recommendations. All shavings are to be thoroughly flushed from the connection by means of a blow-off valve on the tapping equipment. All voids below the pipe and tapping tee shall be filled with 3/4" washed rock bedding material.



3.6 DISINFECTION AND FLUSHING

The Engineer may require the Contractor to clean and disinfect pipeline materials, which have noticeable contamination prior to installation.

Disinfect the work in accordance with the procedures outlined in AWWA C651. If calcium hypochlorite tablets are used they must be attached to the top of the inside of the pipe with a food grade adhesive. Sufficient tablets must be used to form a minimum of 25-ppm free chlorine at the time of filling. Filling of the water main shall be accomplished at a water velocity less than one foot/second. After 24 hours, the Engineer shall test the chlorine residual. If a minimum residual of 10-ppm is not met, the disinfection procedure shall be repeated. Heavily

After disinfection of the water line(s) has been approved, flush the heavily chlorinated water from the mains until the chlorine residual is no higher than that generally prevailing in the system. Procedures to include de-chlorination if necessary must be followed to prevent heavily chlorinated water from entering adjacent streams or irrigation ditches. The Contractor shall make final tests to determine that chlorine and bacteriological levels are safe before the new water system is approved for domestic use. The Contractor shall be responsible for any re-chlorination and flushing necessary to obtain safe bacteriological levels.

Several days are required to obtain the results of bacteriological tests. Coordinate the construction schedule around the requirements of bacteriological testing. The Town may require passing bacteriological tests on two consecutive days.

Flushing shall ensure that sand, rocks or other foreign materials are not left in the pipeline. The contractor shall supply the water necessary for flushing if a sufficient quantity of water is not available from the existing water system. In such a case the Contractor shall present his flushing program to the Engineer before proceeding. Flushing should be done at flow rates sufficient to provide a velocity of at least 2.5 feet / second. A flushing plan shall be submitted to the engineer.

Special care shall be taken when disinfecting and flushing sections of new mains to avoid contaminating the existing system or delivering highly chlorinated water to the system.

3.7 FIELD QUALITY CONTROL

A. General

1. Conduct Pressure and leakage tests in accordance with ANSI/AWWA C 600.
2. Notify the Engineer at least 48 hours in advance of conducting tests so that he may be present during the test.
3. Test completed sections of pipeline as soon as practical after installation. No more than 1,000 feet of pipeline or 10% of the total pipeline (whichever is less) shall be installed without testing the completed portions. The Engineer may waive this requirement on a case-by-case basis if valves will not readily facilitate such testing.
4. Check all valves for smooth operation on opening and closing. All boxes shall be centered and plumb and to the grades specified.

B. Pressure Test

1. General: After concrete thrust blocks have cured all newly laid pipe or any valved section thereof shall be subjected to a hydrostatic pressure of at least 1.5 times the working pressure at the point of testing.

Test Pressure Restrictions:

- a. Not less than 1.5 times the working pressure at the lowest point along the test section.
- b. Not exceed pipe or thrust-restraint design pressures including safety factor.



- c. Shall be of at least 2-hour duration. The engineer may lengthen the test if necessary.
 - d. Not vary by more than ± 5 psi for the duration of the test.
 - e. Not exceed twice the rated pressure (200 psi for 3 inch through 12-inch diameter, and 150 psi for larger than 12 inch diameter) of the valves or hydrants when the pressure boundary of the test section includes closed double disc or solid wedge gate valves or hydrants.
 - f. Not exceed the rated pressure of the valves when the pressure boundary of the test section includes closed resilient-seated gate valves (200 psi) or butterfly valves (150 psi).
 - g. When hydrants are in the test section, the test shall be made against the closed hydrant.
 - h. Valves shall not be operated in either direction at differential pressure exceeding the rated pressure.
 - i. Pressure gauges shall have a maximum range of two times the test pressure and shall be approved by the engineer.
 - j. The engineer can reject test equipment that is of poor quality, in bad condition or of inadequate function and accuracy.
2. Pressurization: Each valved section of pipe shall be filled with water slowly and the specified test pressure; based on the elevation of the lowest point of the line or section under test and corrected to the elevation of the test gauge, shall be applied by means of a pump connected to the pipe in a manner satisfactory to the Town. Valves shall not be operated in either the opening or closing direction at differential pressures above the rated pressure. It is good practice to allow the system to stabilize at the test pressure before conducting the leakage test.
3. Air removal: Before applying the specified test pressure, air shall be expelled completely from the pipe, valves, and hydrants. If permanent air vents are not located at all high points, the Contractor shall install corporation cocks at such points so that the air can be expelled as the line is filled with water. After all the air has been expelled, the corporation cocks shall be closed and the test pressure applied. At the conclusion of the pressure test, the corporation cocks shall be removed and plugged or left in place at the discretion of the Town.
4. Examination: Any exposed pipe, fittings, valves, hydrants and joints shall be examined carefully during the test. Any damage or defective pipe, fittings, valves or hydrants that are discovered following the pressure test shall be repaired or replaced with sound material, and the test shall be repeated until it is satisfactory to the Town.
- C. Leakage Test: The leakage test shall be conducted concurrently with the pressure test.

- 1. Leakage defined: Leakage shall be defined as the quantity of water that must be supplied into the newly laid pipe, or any valved section thereof, to maintain pressure within 5 psi of the specified test pressure after the air in the pipeline has been expelled and the pipe has been filled with water. A drop in pressure in a test section shall not measure leakage over a period of time.
- 2. Allowable leakage (DIP and C-900 PVC pipe): No pipe installation will be accepted if the leakage is greater than that determined by the following formulas:

$$L \text{ (DIP)} = \frac{(SD) (P)^{0.5}}{133,200} \quad L \text{ (PVC)} = \frac{(ND) (P)^{0.5}}{7400}$$

In which L is the allowable leakage, in gallons per hour; S is the length of pipe tested in feet; N is the number of joints in the tested line, D is the nominal diameter of the pipe, in inches; and P is the average test pressure during the leakage test, in pounds per square inch gauge.

- 2. Leakage shall be measured with a suitable meter or calibrated container approved by the engineer.



- D. Service line testing: No service lines are to be tapped to the main prior to the completion of testing and acceptance of the main. Service line connections can be made once a section of main has been accepted, to include bacteriological testing.

Following completion of service line installation, but prior to backfill, all services are to be inspected from the main to the curb stop. This is to be done by pressurizing the service to system static pressure. The test pressure shall be maintained for at least 15 minutes while the Engineer inspects the line and fittings for leaks or other defects.

- E. Conductivity: The Town may require the Contractor to verify the electrical conductivity of new mains if there is reason to doubt that specified measures were taken during installation to assure conductivity. The method of verification shall be at the Town's discretion.

PART 4 MEASUREMENT AND PAYMENT

4.1 WATER MAINS

- A. Water Mains: will be measured and paid for at the Unit Price per Linear Foot under the item Water Main per pipe size, class, and type. The total length of the water main will be measured horizontally along the centerline of the pipe and will include the length of all fittings and valves. Where the pipe enters a building or casing pipe the limit of measurement shall be the outside face of the building or casing pipe. The price includes installations up to 9 feet in depth measured from the top of pipe to existing grade.
- B. Over depth Water Main: The additional cost for over depth installation of water main to include related appurtenances such as valve or hydrant extensions will be measured and paid for at the Unit Price per Linear Foot (measured horizontally as in Water Mains above) under the item Over depth Water Main per over depth range regardless of pipe size.
- C. Valves and Valve Appurtenances: shall be measured and paid for at the Unit Price per Each under the appropriate valve item based upon type and size and shall include the valve, valve box and appurtenances.
- D. Tapping Sleeve and Valve: shall be measured and paid for at the Unit Price per Each under the Tapping Sleeve and Valve item based upon size and shall include the tapping sleeve, valve, valve box and appurtenances.
- E. Fittings: shall be measured and paid for per the Unit Price per Each under the appropriate Fitting item based upon size and type. Change Order will pay for fittings not specifically listed.
- F. Dry Ties: The additional cost of completing a dry tie (system shut down allowed) above and beyond the cost for other Unit Price items shall be measured and paid for at the Lump Sum Price per the appropriate Dry Tie item.
- G. Abandonment: Payment for Abandonment is addressed in the Special Provisions.
- H. Fire Hydrant and Appurtenances: shall be measured and paid for at the Unit Price per Each under the Hydrant item and will include appurtenances, hydrant extensions, and the hydrant bench complete with all excavation, fill, compaction and gravel required. Where it is not obvious from the Drawings that an extension is required the extension will be paid for by change order.
- I. Air Release Valve and Vault: shall be measured and paid for at the Lump Sum Price under the Air Release Valve item and shall include all materials and work detailed on the Drawings.
- J. Reinforced Concrete Encasement: shall be measured and paid for at the Unit Price per Linear Foot per the Reinforced Concrete Encasement item per pipe size.



- K. Restrained Joints: shall be measured and paid for at the Unit Price per Each per the Restrained Joint item per pipe size.

4.2 SERVICE LINES

- A. Service Lines: shall be measured and paid for at the Unit Price per Linear Foot under the Service Line item based upon size regardless of depth. The length shall be measured horizontally along the centerline of the pipe through all fittings from the centerline of the water main to the end of the new service. No additional payment will be made for couplings necessary to connect to existing services. Their cost shall be included in other items.
- B. Service Line Taps: to the Water main shall be measured and paid for at the Unit Price per each per the Corporation Stop item or Corporation Stop with Tapping Saddle item based upon size.
- C. Curb Stop Box: shall be measured and paid for at the Unit Price per Each per the Curb Stop/Box item based upon size.

4.3 GENERAL

The Unit Prices for the above items shall include the cost of maintaining existing water supply, trench excavation, native backfill, trench support system, native bedding and shading, gravel or other imported material where specifically required, markers, thrust blocks, dewatering, testing and inspection, flushing and disinfection and the cost of all materials, equipment, tools and labor incidental or necessary for completion of the work.

4.4 LIMITATIONS

Payment to exceed 85 percent of the contract price for water line installation shall not be made until testing, disinfection and flushing is satisfactorily completed.



PVC PIPE, 7' of cover, bedded in screened rock (GP), 1.5 safety factor.

THRUST RESTRAINT - 100 psi working pressure, Test Pressure 150 psi

SIZE	90° HORIZ. BEND	45° HORIZ BEND	22½° HORIZ BEND	11¼° HORIZ BEND	45° OFFSET URL' / LRL'	22½° OFFSET URL' / LRL'	11¼° OFFSET URL' / LRL'	8"TEE RUN / RUN / BR. RL' / RL'	10" TEE RUN / RUN / BR RL' / RL'	12"TEE RUN / RUN / BR RL' / RL'	DEAD END RL'	REDUCER LG. END RL'
												10"/8"/6"
6"	8'	4'	4'	4'	10' / 4'	5' / 2'	5' / 2'	10' / 10'	10' / 10'	10' / 10'	24'	NA/NA/NA
8"	11'	5'	5'	5'	13' / 5'	7' / 3'	7' / 3'	10' / 10'	10' / 10'	10' / 10'	31'	NA/NA/13'
10"	13'	6'	6'	6'	16' / 6'	8' / 3'	8' / 3'	NA	10' / 10'	10' / 10'	38'	NA/13'/23'
12"	15'	6'	6'	6'	19' / 6'	9' / 3'	9' / 3'	NA	NA	10' / 10'	45'	13'/23'/33'

Notes: BR. = Branch, ULR = Upper Restrained Length, LRL = Lower Restrained Length, RL = Restrained Length

THRUST BLOCKS - 100psi working pressure, Test Pressure 150 psi

	FIRE HYDRANT HORIZONTAL SF	FIRE HYDRANT VERTICAL SF
6"	3.0	3.0

Notes: Area = height (h) x width (w), where w = 1.5 to 2 h



DUCTILE IRON PIPE, with polyethylene encasement, 7' of cover, bedded in screened rock (GP), 1.5 safety factor.

THRUST RESTRAINT- 200 psi Working Pressure and Test Pressure

SIZE	90° HORIZ. BEND	45° HORIZ. BEND	22½° HORIZ. BEND	11¼° HORIZ. BEND	45° OFFSET URL' / LRL'	22½° OFFSET URL' / LRL'	11¼° OFFSET URL' / LRL'	8" TEE RUN / RUN / BR. RL' / RL' / RL'	10" TEE RUN / RUN / BR. RL' / RL' / RL'	12" TEE RUN / RUN / BR. RL' / RL' / RL'	DEAD END RL'	REDUCER LG. END RL'
					7' / 7'cover	7' / 7'cover	7' / 7'cover					10"/8"/6"
6"	15'	10'	6'	3'	26' / 10'	13' / 6'	7' / 3'	10' / 10' / 10'	10' / 10' / 10'	10' / 10' / 10'	61'	NA/NA/NA
8"	20'	10'	6'	3'	34' / 10'	16' / 6'	8' / 3'	10' / 10' / 10'	10' / 10' / 10'	10' / 10' / 10'	81'	NA/NA/34'
10"	24'	10'	6'	3'	41' / 10'	20' / 6'	10' / 3'	NA	10' / 10' / 10'	10' / 10' / 10'	97'	NA/33'/60"
12"	28'	12'	6'	3'	48' / 12'	23' / 6'	12' / 3'	NA	NA	10' / 10' / 20'	116'	34'/62'/84'

Notes: BR. = Branch, ULR = Upper Restrained Length, LRL = Lower Restrained Length, RL = Restrained Length

THRUST BLOCKS - 200 psi working pressure – 1.5 Safety Factor

SIZE	90° HORIZONTAL BEND SF	45° HORIZONTAL BEND SF	22½° HORIZONTAL BEND SF	11¼° HORIZONTAL BEND SF	TEE & DEAD END SF	45° OFFSET UGTB CF	22½° OFFSET UGTB CF	11¼° OFFSET UGTB CF	FIRE HYDRANT HORIZONTAL SF	FIRE HYDRANT VERTICAL SF
6"	5	3	3	2	4	53	29	15	4	4
8"	9	5	3	2	6	91	49	25		
10"	14	7	4	2	10	137	74	38		
12"	19	10	5	3	14	194	105	53		

Notes: Area = height (h) x width (w), where w = 1.5 to 2 h

Offset Bends - UGTB = Upper Gravity Thrust Block, Lower thrust block same as horizontal thrust block.



PIPE, 7' of cover, bedded in screened rock (GP), 1.5 safety factor.

PVC C905, THRUST RESTRAINT - 200 psi working pressure and Test Pressure

SIZE SIZE	90° HORIZ. BEND	45° HORIZ BEND	22½° HORIZ BEND	11¼° HORIZ BEND	12" TEE RUN / BR RL' / RL'	DEAD END RL'	REDUCER LG. END RL'
							10"/8"/6"
14"	23'	10'	6'	6	10' / 10'	68'	32'/42'/54'
18"	28'	12'	6'	6	10' / 10'	86'	75'/67'/58"

THRUST RESTRAINT DUCTILE IRON PIPE, w/
POLY

7' of cover, bedded in screened rock (GP), 1.5 safety factor.

SIZE	90° HORIZ. BEND	45° HORIZ. BEND	22½° HORIZ. BEND	11¼° HORIZ. BEND	12" TEE RUN / BR. RL' / RL"	DEAD END RL'	REDUCER LG. END RL'
16"	28'	12'	6'	3'	10' / 20'	116'	34'/62'/84'

THRUST BLOCKS 200 PSI

SIZE	90° HORIZONTAL BEND SF	45° HORIZONTAL BEND SF	22½° HORIZONTAL BEND SF	11¼° HORIZONTAL BEND SF	TEE & DEAD END SF
14"	21.8	11.8	6	3	10.3
16"	28.4	15.4	7.8	3.9	13.4
18"	35.9	19.5	9.9	5	16.9



SECTION 2560
SEWAGE COLLECTION PIPING AND APPURTENANCES

PART 1 GENERAL

1.1 DESCRIPTION

Work included: Sewage collection main lines, laterals, services, and other related appurtenances to include flushing and testing.

1.2 QUALITY ASSURANCE

Installation shall meet current Colorado Department of Public Health and Environment, CDPHE requirements and manufacturer's recommendations.

1.3 SUBMITTALS/SUBSTITUTIONS

- A. No substitutes will be considered for items listed by manufacturer's name and/or model number in this section unless the words "or equal" are included as a part of the description.
- B. Submittals are required for all proposed substitutions and all items not specifically listed by manufacturer's name and model number.

1.4 PRODUCT DELIVERY, STORAGE AND HANDLING

- A. All Material: Use proper implements, tools and facilities as necessary to safely and efficiently handle all material, and to avoid shock, abrasion or other damage. Under no circumstances shall any materials be dropped. Extra care shall be taken when the temperature approaches or is below freezing.

Pipe shall be stacked per the manufacturer's recommendations but shall not be stacked higher than five feet. Evenly support the barrel of all stored pipe. In distributing material at the work site do not interfere with access to private property, parking, or traffic. It is recommended that only as much pipe as is expected to be laid during the day be strung out along the ditch.

- B. PVC Material: Do not store PVC materials in direct sunlight for prolonged periods. The Engineer may reject PVC materials that have scratches, cuts or evidence of excessive exposure to direct sunlight, all of which can reduce the strength and longevity of the materials. The Contractor is urged to take precautions to avoid abrading or cutting the pipe.
- C. Defective or Damaged Material: All such material shall be rejected and removed from the job site immediately.

1.5 WEATHER CONDITIONS

- A. Weather: Weather protection, temporary heating, snow removal, etc., shall be the Contractor's responsibility.
- B. Temperature:

Mean Daily Temperature is the average of the maximum and minimum temperature.

- 1. No work shall be allowed on the pipelaying portion of the project at temperatures below 20 degrees F or against the manufacturer's recommendations.



2. No work shall be allowed on the pipelaying portion of the project on any day when the Mean Daily Temperature will be 32 degrees F or below.
3. A succession of three consecutive days with the Mean Daily Temperature 32 degrees F or below shall be grounds for shutting down the pipelaying portion of the project. Resumption of work on the pipelaying portion of the project will be allowed after three consecutive days when the Mean Daily Temperature is 32 degrees F or above.
4. The Contractor shall coordinate with the Engineer when temperatures approach the conditions for shut down of the pipe laying operations. The Contractor may propose and institute suitable protective measures to continue work if authorized by the Engineer.

PART 2 PRODUCTS

MATERIALS

A. Polyvinyl Chloride (PVC) Pipe and Fittings:

1. 4-inch to 15 inch inside diameter: ASTM D 3034, SDR35.
2. 18-inch to 27 inch inside diameter: ASTM F 679, Wall Thickness T-1.
3. Joints: ASTM D 3212, rubber gasketed bell and spigot type with integral bell.
4. Gaskets: ASTM F 477.

B. Ductile Iron Pipe (DIP):

1. Pipe: ANSI A21.51
2. Cement lining: ANSI A21.4
3. Push-on or Mechanical Joints: ANSI A21.11
4. Wall Thickness: Class 50 minimum.

C. Saddles: for 4 inch or 6-inch diameter service line connections to existing lines shall be of the gasketed type with stainless steel bands and specifically made for the size and type main being connected to. A submittal is required. Solvent weld type saddles are not acceptable.

D. Cleanouts:

1. Pipe and Fittings: Shall be the same as the sewer line.
2. Cover: Neenah #R-1970 or approved equal.

E. Encasements:

1. Concrete: 3,000 psi compressive strength minimum, Type II, Portland Cement 6 sack per cubic yard mix.
2. Reinforcing Steel: Grade 40, ASTM A615.

F. Couplings: for connecting two plain ends of PVC shall be PVC bell x bell couplings. All other couplings shall be stainless steel sewer clamp couplings, style LSS 1 by Romac Industries, Inc., or equal.

G. Sewer Marker Posts: Carsonite utility marker with sewer decal 107-CS model CUM-375 CRM 3072-07 (72-inch length) by Carsonite International, Carson City, Nevada.

H. Stub Markers: New 4x4 green treated timber for buried installation. Length shall be as required to extend from designated grade to the stub.



PART 3 EXECUTION

3.1 PIPE INSTALLATION

- A. General: Minimum depth of cover is 5'. Pipe placement shall conform to manufacturer's recommendations. Materials shall not be dropped into the trench but shall be lowered by either hand or machine. Pipe laying shall proceed upgrade with the spigot ends of bell and spigot pipe pointing in the direction of flow.

The entire surface of all pipe shall be clean when laid. Interior surfaces of pipe sockets shall be cleaned when the pipe is laid and the joints completed. During pipe laying operations, no debris, tools, clothing or other material shall be placed in the pipe. When pipe laying operations are not being conducted or are temporarily suspended, all pipe openings are to be plugged with an appropriate size sewer plug. Pipes not making a good fit shall be removed from the job site.

Field cut sections of pipe shall only be used for making connections to manholes, other structures or existing pipelines when make up piping is needed to make the closure.

Each pipe shall be laid true to line and grade to form a close concentric joint with the adjoining pipe and to prevent sudden offsets to the flow line. Pipe grade shall be uniform between manholes. No pipes are to be placed in the trench or final joints made, until unstable trench bottoms have been stabilized and fine grading of the trench bottom to accommodate the pipe invert has been completed. Immediate partial backfill may be required to prevent accidental deflection of the pipe.

State Health regulations require that sewer mains and service lines be installed a 10-foot minimum clear distance from potable water mains and services. If this separation cannot be maintained consult with the Engineer for any special precautions that may be required. When authorized to connect new pipe to an existing plain end pipe use an approved transition coupling tightened to a watertight fit, and encased in plain concrete encasement extending one foot beyond each end of the coupling.

- B. Plain or Reinforced Concrete Encasements: shall be constructed as shown on the Drawings or described in the Specifications.

Install temporary supports consisting of concrete blocks or bricks to support the pipe in place where long encasements are required. Not more than two supports shall be used for each pipe length, one adjacent to the shoulder of the bell and the other near the spigot end.

No encasements shall be poured until the Engineer has inspected the pipe to be encased, reinforcement and supports. The encasement shall cure a minimum of 24 hours at no less than 40 degrees F prior to backfilling.

3.2 SERVICE LINE INSTALLATION AND CONNECTIONS

Minimum depth of cover is 5 feet.

Service connections to new mains shall be made with full-bodied wyes meeting the same specifications as the sewer main.

Service connections to existing mains shall be made with saddles. The main shall be cut in a workman like manner using proper tools and a template for the saddle. The manufacturer's recommendations shall be followed and recommended sealants used to assure a watertight connection. All taps to existing mains shall be completed by Steamboat Springs Water at the cost of the Contractor.

Provide all bends required for proper vertical or horizontal alignment.



Service connections to mains shall be bedded in imported bedding material as necessary to support all fittings.

Do not backfill a service until the Engineer has visually observed the service and authorized it to be backfilled. The service shall be checked for grade, water tightness, cleanout installation and adequate cover.

All services to undeveloped property or to vacant lots shall be watertight, have the end capped, and extend a minimum of 6 feet into the property.

Sewer Marker Posts shall be installed at the end of all unconnected services. The posts shall be buried 2-1/2 feet and extend above grade 3-1/2 feet.

Stub Markers shall also be installed at the end of all unconnected services. The markers shall extend from finished grade to the stub in open areas, and shall extend from subgrade to the stub in roadways.

The minimum separation between service line connections shall be 10 feet.

No live service lines shall be connected to new mains or new service lines until the latter have been tested unless otherwise approved by the Engineer.

3.3 CLEANOUT INSTALLATION

Cleanout structures shall be located and constructed as shown in the Drawings, or as directed by the Engineer. The cleanout shall have a true and smooth interior to allow easy access for inspection lights, plugs, and cleaning equipment.

Cleanouts shall be installed no greater than 100 feet apart and at all 45 degree or larger bends. Sizing, location and installation shall be in accordance with the Uniform Plumbing Code (UPC).

Final grade of the cleanout cover shall be as specified for manhole lids.

3.4 FIELD QUALITY CONTROL

A. General: Test pipe line promptly after installation through completion of backfill. No more than 800 feet or 10 percent of the total pipeline, whichever is less, shall be installed without testing the completed portions.

B. Lamping: Alignment, grade and pipe condition will be checked by the Engineer. A light will be flashed between manholes by means of a flashlight or by reflecting sunlight with a mirror. Proper alignment shall consist of a "full moon" clearly visible at the opposite end of the line from the observer's location.

Prior to the lamping test, the Contractor shall put water in the upper section of the line and let it flow out through the new lines and manholes. During the lamping tests, the Engineer shall check for standing water indicating sags or settled sections of pipe or manholes. The maximum amount of standing water allowed in any pipe or manhole shall be 3 percent of the pipe's diameter or 1/2 inch whichever is smaller.

The Contractor shall correct any deficiencies noted such as poor alignment, displaced pipe, debris in the pipe, or any other defects. Tests will be repeated after completion of repair and backfill.

C. Leakage: After lamping tests are completed, tests for water tightness shall be made by the Contractor in the presence of the Engineer. Either a water exfiltration, a water infiltration or an air pressure test will be required depending on the section of sewer line to be tested. The type of test conducted is subject to the Engineer's approval.



1. Exfiltration test: Exfiltration tests shall be performed as follows: Plugs shall be put in the upstream end of both manholes at the ends of the section to be tested. The upper manhole shall have at least 2 feet of water above the invert at the center of the manhole. Exfiltration tests shall not be used if the vertical difference between the inverts at the center of the manholes is greater than 20 feet. The maximum allowable leakage shall not exceed 100 gallons per day per mile per inch diameter.
2. Infiltration test: The infiltration test will be performed with a weir supplied by the Engineer. The maximum allowable infiltration rate shall be equal to that allowed in the exfiltration test.
3. Air test: In lieu of a water exfiltration test, the Contractor may test sewer line by means of an air test. The Contractor's testing procedure and equipment shall be approved by the Engineer prior to proceeding. All lines shall be pressurized in the Engineer's presence and all pressurized lines shall have the pressure released in the Engineer's presence. Gauges used to monitor the air test and fill and drain lines shall be located above grade not in the manhole.

The length of time for a 0.5 psig pressure drop from 3.5 psig to 3.0 psig shall not be less than the following table:

<u>Specification Time Required for 0.5 psig Pressure Drop</u> <u>For Size and Length of Pipe Indicated (min:sec)</u>								
<u>Pipe Dia.</u> <u>(inches)</u>	<u>100'</u>	<u>150'</u>	<u>200'</u>	<u>250'</u>	<u>300'</u>	<u>350'</u>	<u>400'</u>	<u>450'</u>
4	1:53	1:53	1:53	1:53	1:53	1:53	1:53	1:53
6	2:50	2:50	2:50	2:50	2:50	2:50	2:51	3:12
8	3:47	3:47	3:47	3:47	3:48	4:26	5:04	5:42
10	4:43	4:43	4:43	4:57	5:56	6:55	7:54	8:54
12	5:40	5:40	5:42	7:08	8:33	9:58	11:24	12:50
15	7:05	7:05	8:54	11:08	13:21	15:35	17:48	20:02
18	8:30	9:37	12:49	16:01	19:14	22:26	25:38	28:51
21	9:55	13:05	17:27	21:49	26:11	30:32	34:54	39:16
24	11:24	17:57	22:48	28:30	34:11	39:53	45:35	51:17
27	14:25	21:38	28:51	36:04	43:16	50:30	57:42	66:54

The Contractor shall locate and repair the defective joints or pipe in every section of line which exceeds the allowable infiltration/exfiltration rate or fails the air test.

The Contractor shall retest the line until the line passes the test.

- D. Deflection: The maximum allowable pipe deflection is 5 percent of the pipe diameter.

Deflection testing may be required if the Engineer suspects excessive pipe deflection or if the Contractor's pipe bedding procedures; in particular, tamping and compaction of the bedding, are questionable in the opinion of the Engineer.

The deflection test will be performed by the Contractor in the presence of the Engineer. The test shall be conducted by pulling a 5 percent deflection mandrill through the pipe. If the mandrill does not pass a point between manholes A and B when being pulled from A to B, the mandrill will be pulled from B to A.

The Contractor shall provide all personnel and equipment to include deflection mandrills and a water truck if necessary.



If areas of greater than 5 percent deflection are encountered, the Engineer may require that the deflection test be repeated with a 7 percent deflection mandrill or require excavation of the line in the area of excessive deflection to determine the cause. All areas of excess deflection shall be corrected by the Contractor at his expense.

PART 4 MEASUREMENT AND PAYMENT

4.1 SANITARY SEWERS

- A. Sanitary Sewers: will be measured and paid for at the Unit Price per Linear Foot under the item Sewer Line per pipe size, type, and depth. The depth of sewer will be measured vertically from the invert of the sewer to the existing ground level directly above the pipe. The total length of the sewer will be measured horizontally between centerline of manholes. Where the pipe enters a building or casing pipe the limit of measurement shall be the outside face of the building or casing pipe. Pipe installed from existing stubs shall be measured from the beginning of that pipe to the centerline of the next manhole.
- B. Reinforced Concrete Encasement: shall be measured and paid for at the Unit Price per Linear Foot per the Reinforced Concrete Encasement item per pipe size.

4.2 SERVICE LINES

- A. Service Lines: will be measured and paid for at the Unit Price per Linear Foot under the item Sewer Service per the size and type of pipe regardless of depth. The length shall be measured horizontally along the centerline of the pipe through all fittings from the centerline of the main sewer to the end of the new service.
- B. Cleanouts: shall be measured and paid for at the Unit Price per Each under the Cleanout item per cleanout size.

4.3 GENERAL

The Unit Prices for the above items shall include the cost of maintaining existing sewage flows, trench excavation, native backfill, trench support system, native bedding and shading, gravel or other imported material where specifically required, markers, dewatering, flushing, testing and inspection, and the cost of all materials, equipment, tools and labor incidental or necessary for completion of the work.

4.4 LIMITATIONS

Payment to exceed 85 percent of the contract price for sewer line installation shall not be made until testing is satisfactorily completed.



SECTION 2565 WATER AND SEWER LINE CROSSINGS

PART 1 GENERAL

1.1 DESCRIPTION

- A. Work included: This specification shall define the precautions required to protect water systems when water and sewer mains intersect.
- B. Related work described elsewhere:
 - 1. Trenching, Bedding and Backfill, Section 2221
 - 2. Water Distribution Piping and Appurtenances, Section 2555
 - 3. Sewage Collection Piping and Appurtenances, Section 2560

1.2 QUALITY ASSURANCE

Water and sewer main crossings shall be done in accordance with current Colorado Department of Public Health and Environment, CDPHE requirements and these Specifications. In the event of conflict, the more stringent requirements, as determined by the Engineer, shall govern.

PART 2 PRODUCTS

MATERIALS - Materials shall be as specified for waterline and/or sewerline construction. See Section 2555 or 2560 as appropriate.

PART 3 EXECUTION

3.1 CROSSING CONDITIONS

Six different crossing conditions have been identified for separate consideration. Each of the conditions is visually represented by Water and Sewer Main Crossing Conditions Detail included in this specification.

3.2 CROSSING REQUIREMENTS

- A. Condition #1: When a new water main crosses less than 18 inches above a new sewer main.
 - 1. A joint of pipe from each main shall be centered on the other main.
 - 2. Caution: The Contractor must plan the installation of the first utility installed so that the second utility installed will cross at the center of a full length of pipe of the first utility.
 - 3. Backfill between the two pipes shall be compacted imported bedding material or lean concrete.
- B. Condition #2: When a new water main crosses below a new sewer main the same precautions as identified for condition #1 shall be followed, except that backfill between the two pipes shall be with lean concrete.
- C. Condition #3: When a new water main crosses less than 18 inches above an existing sewer main the following shall be done:



1. Avoid exposing existing sewer main if possible. If joints are exposed, or the sewer main is damaged, the section of sewer main shall be plain concrete encased for the full width of the water main trench.
2. A full joint of the water main shall be centered over the sewer main.
3. Backfill between the two pipes shall be compacted imported bedding material or lean concrete.

D. Condition #4: When a new water main crosses below an existing sewer main.

1. The sewer mains shall be excavated to 10 feet on either side of the point at which the water line crosses and reinforced concrete encased. This work shall be done prior to water main installation and an adequate time in advance to permit the concrete encasement to reach adequate strength (48 hours minimum) before the water main is installed below the sewer.
2. A full joint of the water main shall be centered under the sewer main.
3. Backfill between the water main and the concrete encasement shall be with lean concrete.

E. Condition #5: When a new sewer main crosses less than 18 inches below an existing water main.

1. All exposed water main joints shall be plain concrete encased for a distance of 1 foot each side of the joint.
2. A full joint of sewer main shall be centered on the water main.
3. Backfill between the two pipes shall be compacted imported bedding material or lean concrete.

F. Condition #6: When a new sewer main crosses above an existing water main.

1. Avoid exposing the water main if possible. If joints are exposed or the water main is damaged, the section of main shall be plain concrete encased for the full width of the sewer main trench.
2. A full joint of sewer main shall be centered on the water main and the joints of the sewer main encased in concrete for one foot each side of the joint.
3. Backfill between the two pipes shall be lean concrete.

3.3 LOCATION OF MAINS AND SERVICES

The Owner of the distribution or collection system will attempt to provide, upon the Contractor's request, as accurate information regarding utility locations as is available. The Contractor will ultimately be responsible for line location and protection.

3.4 DAMAGE/REPAIR OF EXISTING MAINS AND SERVICES

When excavating in the area of existing water and sewer mains, the Contractor shall notify the system Owner and request accurate field locations. When excavating for crossings of existing mains, the Contractor shall use extreme caution to avoid damaging them. If the Contractor accidentally damages existing mains he shall exercise the following repair procedures in addition to the standard crossing requirements specified in Section 3.2.



- A. Damage to Existing Sewer Main or Service: Existing sewer mains or services shall be repaired by replacement of the damaged section of pipe with a new pipe of identical material or a new section of PVC sewer pipe. The length of the repair pipe shall be as necessary to accomplish the repair. Joints between the repair pipe and the existing pipe shall be made with an approved rubber coupling. As a minimum, all such joints shall be encased in concrete a distance of 1 foot either side of the joint. Additional concrete encasement may be required depending on the crossing condition as specified in Section 3.2.
- B. Damage to Existing Water Main or Service: Existing water mains or services shall be repaired by installing a new section of pipe in the damaged area or by use of repair couplings. New pipe for repairs shall be of similar material to the existing pipe or CL 52 DIP for mains. Repair couplings shall be suitable for the type of pipe with which they are to be used. Both the type of pipe and the type of repair couplings shall be approved by the Engineer and the operator of the water system prior to their use.

3.5 TEST HOLES

Test holes may be required for crossing conditions 3, 4, 5, and 6 for the purpose of determining the exact elevation of the existing utility. This requirement will be noted on the Drawings at the point of intersection of the mains.

PART 4 MEASUREMENT AND PAYMENT

4.1 SEWER AND WATER LINE CROSSINGS

Separate payment will be made for the additional cost associated with each crossing per the Sewer and Water Line Crossing pay item by condition per each crossing. If reinforced concrete encasement is required it shall be paid for by the reinforced concrete encasement bid item. If no bid item appears in the Bid Schedule payment will be made by Change Order.

4.2 SERVICE LINE CROSSINGS

In general, no separate payment will be made for crossing water service lines located by the system Owner. If a water service line is not located by the system Owner or is incorrectly located, and the Contractor subsequently damages the service line, payment for repair shall be made by Change Order. No separate payment will be made for crossing sewer service lines when installing water mains.

When installing a new sewer main separate payment for sewer service line crossings and subsequent connection to new sewer main may be made per appropriate unit price Bid item.

4.3 REPAIR OF DAMAGED MAINS

Repair of damaged mains shall be the Contractor's responsibility. No separate payment will be made for repair of mains damaged by the Contractor.

If in the Contractor's opinion, damage to a main line is a result of conditions beyond his control, the Contractor shall within 5 days of the event, present a written request to the Engineer for reimbursement of costs incurred.



SECTION 2609
GRAVEL SURFACING

PART 1 GENERAL

1.1 DESCRIPTION

Work included:

Furnishing and installing aggregate and pit run materials to form the subbase, base or traveled surface, and shouldering sections of roads, drives, and parking areas.

1.2 QUALITY ASSURANCE

- A. Standard Specifications: Reference the current edition of Standard Specifications for Road and Bridge Construction, CDOT, State of Colorado herein called Standard Specifications.
- B. Testing: Testing required to be supplied by the Contractor shall be provided through a recognized independent testing laboratory.

1.3 SUBMITTALS

- A. Comply with Section 1300.
- B. Samples: Supply samples of subbase, base and surface course materials in the quantities necessary for conducting compliance tests when requested.
- C. Materials Test Results:
 - 1. If the Owner has not approved the materials for another project during the current construction season submit the following:

Copies of current test results which establish the quality of the materials and properties of the finished product.
 - 2. If the Owner has approved the materials for another project during the current construction season submit the following:
 - a. Evidence of the approval.
 - b. Copies of current test results which establish the quality of the materials and properties of the finished product only if requested by the Engineer.
- D. Independent Testing Laboratory: Unless waived by the Engineer, submit the name and qualifications of the independent testing laboratory prior to proceeding with any testing.



PART 2 PRODUCTS

2.1 ROAD AGGREGATE SUBBASE COURSE

Subbase course shall be well graded Class 3 Aggregate Base Course per Section 703.03 of the Standard Specifications with the following modifications:

1. Crushed reclaimed concrete or asphalt material shall not be used.
2. Percentage passing the 6-inch sieve shall be 100.
3. Percentage passing the No. 4 sieve shall be 30-65.
4. Percentage passing the No. 200 sieve shall be 3-15.

2.2 ROAD AGGREGATE BASE COURSE

Base course shall be well graded Class 6 Aggregate Base Course per Section 703.03 of the Standard Specifications with the following modification:

Crushed reclaimed concrete or asphalt material shall not be used.

2.3 ROAD AGGREGATE SURFACE COURSE (For roads not to receive a hot bituminous pavement surface for several years.)

Surface course shall be well graded Class 6 Aggregate Base Course per Section 703.03 of the Standard Specifications with the following modifications:

1. Crushed reclaimed concrete or asphalt material shall not be used.
2. Percentage passing the No. 200 sieve shall be 8 to 12.

2.4 SHOULDERING

Road aggregate surface course materials shall be used for shouldering.

PART 3 EXECUTION

3.1 GENERAL

Weather limitations: Gravel courses shall be constructed only when atmospheric temperature is above 35 degrees F and frost penetration has not occurred. Material shall not be mixed or placed during rain.

3.2 PREPARATION

Check and Prepare Existing Surface: Check the surface on which the new material will be placed for contamination, ruts, and other surface imperfections. Where there is evidence of soft spots, proof roll the suspect area with a loaded ten-yard dump truck in the presence of the Engineer.

No subbase, base, surface or shouldering course material shall be placed on soft, spongy, frozen or unstable surfaces, or surfaces not conforming to geometric requirements.

Soft and yielding material and portions of the subgrade which show deflection or surface defects shall be scarified and re- compacted or removed, replaced, and compacted with acceptable material. See Section 2223 Road Subgrade Construction for requirements.



3.3 PLACEMENT

Placement shall be per Section 304.04 of the Standard Specifications with the following modification:

Shouldering material shall taper from the Hot Bituminous Pavement section to the top of the base course section at the outside edge of the shoulder. All means necessary to protect the pavement shall be used and any damage shall be at the expense of the Contractor.

3.4 MIXING

Mixing shall be per Section 304.05 of the Standard Specifications.

3.5 SHAPING AND COMPACTION

Shaping and compaction shall be per Section 304.06 of the Standard Specifications.

3.6 DRIVEWAY AND APPROACHES

Place gravel courses at all driveways and street approaches to provide a smooth transition from the finished grade of the new installation to the grade of the existing driveway or approach. The length of the transition shall be as agreed upon with the Engineer.

3.7 FIELD QUALITY CONTROL

A. Surface and Thickness Testing:

The surface and thickness shall be tested by the Contractor in the presence of the Engineer per Section 304.06 of the Standard Specifications with the following modifications.

1. Subbase, Base, and Surface courses shall be tested.
2. The surface variation allowed for Class 6 material shall be 1/4 inch.
3. Thickness measurements shall be made by test holes, at least 3 inch diameter, through the course. One depth measurement shall be made for each 500 square yards, or part thereof, for each course. Thickness measurements may be waived when gravel is installed with "bluetop" staking.
4. Variations exceeding the above measurements shall be corrected by removing material, installing new material, or re-working existing material.

B. Compaction Testing of Installed Materials:

1. The Contractor shall perform compaction tests per AASHTO T 180 (ASTM D 1557 Modified), ASTM D 1556, ASTM D 2167, and nuclear methods (ASTM D 2922 and D 3017) to establish compaction control and to determine conformance with the specifications. The Contractor shall supply the Engineer with copies of all test results. The frequency of the testing shall be as necessary to assure the installed material has been properly compacted but shall be no less than one passing test every 100 linear feet of roadway, alternating right lane, centerline and left lane for each type of material placed.
2. The Owner may also perform compaction tests to monitor the work. The Contractor shall assist the Owner as necessary to complete the testing. Testing by the Owner will not relieve the Contractor of responsibility for the completed work.



C. Quality Testing of Installed Materials:

The Owner may take representative samples of the installed materials for quality testing and gradation testing. If test results indicate the quality and gradation of the installed materials is not as specified, the Owner may require the Contractor to conduct additional testing to determine the extent of the work not in compliance with the specifications.

3.8 MAINTENANCE

Maintenance: Gravel surfaces shall be maintained by the Contractor until the certificate of substantial completion is issued or the Owner has agreed in writing to begin maintenance.

PART 4 MEASUREMENT AND PAYMENT

4.1 SUBBASE COURSE, BASE COURSE, AND SURFACE COURSE

- A. For the Design Road Section: shall be measured and paid for at the Bid Unit Price per Cubic Yard measured in place per material type based upon the actual surface area covered and the thickness of material installed not to exceed design thickness.
- B. For Driveways and Approaches: shall be measured and paid for at the Bid Unit Price per Cubic Yard measured in place per material type based upon the actual area covered and an agreed upon average thickness.

4.2 SHOULDERING

Shouldering: shall be measured and paid for at the Bid Unit Price per Cubic Yard measured in place per material type based upon the length of material and actual cross section installed.



SECTION 2612
HOT MIX ASPHALT PAVEMENT SUPERPAVE

PART 1 GENERAL

The Town of Hayden requires that all new asphalt roadway pavement and overlay projects be constructed in accordance with the most recent edition of the Routt County Road and Bridge Roadway Standards.

PART 1.1 DESIGN INTENT

These specifications include general requirements applicable to all types of plant mixed hot mix asphalt pavements (HMAP). This work consists of one or more courses of asphalt mixture constructed on a prepared foundation in accordance with specifications. The design intent is to provide pavement with adequate thickness and quality to provide a serviceable life of 20 years. It is also the intent to provide construction in accordance with these specifications and with a high standard of practice. This item shall include all labor, equipment, materials to manufacture, place and compact asphalt cement concrete for pavement purposes.

PART 2 MATERIALS

The hot mix asphalt shall be composed of a mixture of aggregate, filler and asphalt cement. Some mixes may require hydrated lime and/or polymer modified asphalt cement. Some mixes may allow up to 20% reclaimed asphalt pavement (RAP).

2.1 Aggregate

Aggregates for HMAP shall be of uniform quality, composed of clean, hard, durable particles of crushed stone, crushed gravel, or crushed slag. Excess of fine material shall be wasted before crushing. The material shall not contain clay balls, vegetable matter, or other deleterious substances and shall meet the following requirements.

TABLE 2.1.1- AGGREGATE PROPERTIES

Aggregate Test Property	Coarse: Retained on #4	Fine: Passing the #4
Fine Aggregate Angularity, CP-L 5113 Method A Traffic Level 1 & 2 Traffic Level 3 to 5		40% Min. 45% Min
Two Fractured Faces, CP-45 Top and Middle Lifts Bottom Lifts	80% Min. 70% Min.	
LA Abrasion, AASHTO T 96	45% Max.	
Flat and Elongated (Ratio5:1) %, AASHTO M 283	10% Max.	
Adherent Coating (Dry Sieving) ASTM D 5711	0.5% Max.	
Sand Equivalent. AASHTO-L 176		45% Min.

The HMAP gradation for the proposed design job-mix gradation shall be wholly within the control point gradation range set forth in the following Table 2.1.2. The allowable job mix gradation for production shall be the design job mix gradation with the tolerances of Part 14.0 applied. The proposed design job mix and the final allowable job mix gradation for production shall report all sieve sizes listed in the table.



TABLE 2.1.2 - GRADATION RANGE
(Percent by Weight Passing Square Mesh Sieves, AASHTO T 11 & T 27)

Sieve Size	SX (1/2" nominal)		S (3/4" nominal)		SG (1" nominal)	
	Control Points	Restricted Zone*	Control Points	Restricted Zone*	Control Points	Restricted Zone*
1 1/2"					100	
1"			100		90-100	
3/4"	100		90-100			
1/2"	90-100					
3/8"						
#4						39.5
#8	28-58	39.1	23-49	34.6	19-45	26.8-30.8
#16		25.6-31.6		22.3-28.3		18.1-24.1
#30		19.1-23.1		16.7-20.7		13.6-17.6
#50		15.5		13.7		11.4
#200**	2.0-8.0		2.0-7.0		1.0-7.0	

*The restricted zone is a guideline only. It is recommended that mix design gradations go above the restricted zone boundaries, on the "fine" side.

**These limits shall include the weight of lime at 1.0%.

Voids in Mineral Aggregates (VMA)

VMA shall be based on tests of the Bulk Specific Gravity of the Compacted Mix (CP-L 5103) and Aggregate (T 84 & T 85), and calculated according to CP-48. All mixes shall meet the minimum VMA specified in Table 2.1.3, below.

TABLE 2.1.3 MINIMUM VMA, %

Nominal Maximum* Particle Size	Air Voids**		
	3.5%	4.0%	4.5%
1"	12.5	13.0	13.5
3/4"	13.5	14.0	14.5
1/2"	14.5	15.0	15.5

* Nominal Maximum Particle Size is defined as one sieve size larger than the first sieve to retain more than 10%, but shall not exceed the 100% passing size. The Nominal Maximum Particle Size can vary during mix production even when the 100% passing size is constant.

**Minimum VMA criteria applies to both design and plant produced mix. The minimum VMA criteria shall be linearly interpolated based on actual air voids.



2.2 Asphalt Cement

The CONTRACTOR shall provide to the TOWN an acceptable 'Certifications of Compliance' of each applicable asphalt cement grade from the supplier upon non-conformance with the specifications the asphalt cement may be rejected as directed by the TOWN. When production begins the CONTRACTOR shall upon request provide to the TOWN a one quart can of each specified asphalt cement. Additionally, when requested the contractor shall provide the refinery test results that pertain to the asphalt binders used during production.

Asphalt Cement binder shall meet the requirements of the Superpave Performance-Graded Binders (PG) as presented in Table 2.2.1 below.

TABLE 2.2.1 - PROPERTIES OF SUPERPAVE PERFORMANCE GRADED BINDERS

Property	PG 58-28	PG 64-28	PG 76-28
Traffic Level: Recommended Usage	1 and 2	2 through 5	3 through 5
Flash Point Temperature, °C, AASHTO T 48	230 Min.	230 Min.	230 Min.
Viscosity at 135 °C, Pas, ASTM D 4402	3 Max.	3 Max.	3 Max.
Dynamic Shear, Temperature °C, where $C^*/\sin \delta @ 10 \text{ rad/sec.} \geq 1.00 \text{ Kpa}$, AASHTO TP 5	58	64	76
Rolling Thin Film Oven Residue Properties, AASHTO T 240			
Mass Loss, %, AASHTO T 240	1.00 Max.	1.00 Max.	1.00 Max.
Dynamic Shear, Temperature °C, where $G^*/\sin \delta @ 10 \text{ rad/sec.} \geq 2.20 \text{ Kpa}$, AASHTO TP 5	58	64	76
Elastic Recovery ¹ , 25°C, % Min.*	N/A	N/A	50 Min.
Pressure Aging Vessel Residue Properties, Aging Temperature 100 °C AASHTO PP1			
Dynamic Shear, Temperature °C, where $G^*/\sin \delta @ 10 \text{ rad/sec.} \leq 5,000 \text{ Kpa}$, AASHTO TP 5	19	28	28
Creep Stiffness, @ 60 sec. Test Temperature in °C, AASHTO TP 1	-18	-18	-18
S, Mpa, AASHTO TP 1	300 Min.	300 Min.	300 Min.
m-value, AASHTO TP 1	0.300 Max.	0.300 Max.	0.300 Max.
Direct Tension Temperature in °C, @ 1.0 mm/min., Where Failure Strain >1.0%, AASHTO TP 3	-18	-18	-18

* Elastic Recovery by Task Force 31, Appendix B Method

2.3 Additives

The TOWN generally does not require hydrated lime to be added to asphalt pavement. When required, lime shall be added at the rate of 1% by dry weight of the aggregate and shall be included in the amount of material passing the No.200 sieve. Hydrated lime for aggregate pretreatment shall conform to the requirements of ASTM C 207, Type N. In addition, the residue retained on a 200-mesh sieve shall not exceed 10% when



determined in accordance with ASTM C 110. (Drying of the residue in an atmosphere free from carbon dioxide will not be required.)

2.4 Tack Coat - The emulsified asphalt for Tack Coats shall be SS-1h and conform to AASHTO M140.

PART 3 MIX DESIGN AND PLANT PRODUCED MIXTURE REQUIREMENTS

The mix design materials shall be those listed in Section 2.0 and used for the project. No substitutions are allowed. The TOWN shall indicate on MGPEC Form #9, the project specific criteria concerning (1) mix design method, (2) traffic level, (3) asphalt cement type, (4) mixture grading, and (5) maximum amount of RAP allowed. This information shall be provided on MGPEC Form #9, 'Requirements for Hot Mix Asphalt Pavement (HMAP)'. Typically, the TOWN requires an aggregate gradation of Grading S or Grading SX and an asphalt binder of performance grade 64-28 (PG 64-28) for both arterial roads and collector roads. Variations from these standards will require special approval.

3.1 Superpave Mixture Design Method

The CONTRACTOR shall submit a proposed design job mix for each mixture required by the Contract. The design shall be determined using Colorado Procedure CP-L 5115 for the Superpave Method of Mixture Design. Guidance is provided in "Superpave Level 1 Mix Design" SP-2 published by the Asphalt Institute. Mix designs shall meet the following requirements of Table 3.1:

TABLE 3.1 SUPERPAVE MIXTURE PROPERTIES

Traffic Level	0	1 & 2 & 3
Traffic Loading, Total 18-kip ESALs Over Design Life (Usually 20 Years)	Non-Vehicular or Paths	1) <300,000 2) 300,000 to <1.0 Million 3) 1.0 to <3.0Million
Initial gyrations, N _{initial} (Air Void >11.0%), For Information Only	6	7
N _{initial} Air Voids, For Information Only	>8.5	>9.5
Design gyrations, N _{design} (Air Void:3.5% to 4.5) (See Note 1)	50	75
Hveem Stability (Minimum) CP-L 5106 (Grading S & SX only)	n/a	28
Voids Filled with Asphalt, %, MS-2	70-80	65-78
Lottman, Tensile Strength Ratio, % Retained, CP-L 5109, Method B	80 Min.	80 Min.
Lottman, CP-L 5109 Dry Tensile Strength, psi	30 Min.	30 Min.
VMA %. CP-48		

Note 1: Maximum Theoretical Specific Gravity of mix by CP-51.

Note 2: Refer to Section 14.0 for production tolerances.

PART 4 MIXTURE DESIGN SUBMITTALS

4.1 General Requirements

The CONTRACTOR shall submit all mixture designs, Certificates of Compliance, and laboratory data to the TOWN for approval at least 7 calendar days before construction is to begin. The mix design must be approved by the TOWN prior to the start of construction.



4.2 Mix Design

Mixture designs shall be performed in a materials laboratory under the direct supervision of and shall be stamped and signed by a Professional Engineer licensed in Colorado and practicing in this field. In addition, the CONTRACTOR shall submit as part of the mixture design, documents to verify the following:

1. Source of materials.
2. Gradation, specific gravity, source and description of individual aggregates and the final blend.
3. Aggregate physical properties.
4. Source and Grade of Asphalt cement.
5. Proposed Design Job Mix -aggregate and additive blending, final gradation shown on 0.45 power graph, optimum asphalt content.
6. Mixing and compaction temperatures used.
7. Mixture properties determined at a minimum of four asphalt contents and interpolated at optimum and graphs showing mixture properties versus asphalt content.

The TOWN reserves the right to verify the CONTRACTOR'S mix design for each hot asphalt pavement grading utilizing materials actually produced and stockpiled. If requested, the CONTRACTOR shall provide a sufficient quantity of each aggregate, mineral filler and additive for the required laboratory tests, if required by the TOWN. The TOWN may request a Certificate of Conformance or Certificate of Compliance at any time on any material used.

4.3 Changes in Source or Grade

Should a change in the source Lime occur, or more than one temperature grade change on either the high or low end of Asphalt Cement (AC) occur, a one-point verification test (at optimum asphalt content) of the mix must be performed to verify that the applicable criteria shown on Table 2.1.3 (VMA), or 3.1 (Superpave) is still met. If this testing shows noncompliance, a new Design Job Mix shall be established before the new AC or Lime source is used. Any change in aggregate type or source will require a new mix design. The one-point verification test may be performed on lab mixed samples or on Plant mixed samples.

4.4 Mix Verification

Production verification shall occur prior to the start of the project. The production verification shall be performed by certified technicians to verify the volumetric properties of the mix. If the mix has been produced for another project within the last 90 days, data from that project can be submitted for this verification. Volumetric properties of the mix verification testing shall be within the following tolerances. The mix verification test reports shall be submitted to the TOWN prior to mix placement.

TABLE 4.1 MIX VERIFICATION TOLERANCES

Air Voids	+/- 1.2%
VMA	+/- 1.2%
Asphalt Cement Content	+/-0.3%



PART 5 EQUIPMENT

5.1 Mixing Plant

The mixing plant shall be capable of producing a uniform material, have adequate capacity, and be maintained in good mechanical condition. Defective parts shall be replaced or repaired immediately if they adversely affect the proper functioning of the plant or plant units, or adversely affect the quality of the hot bituminous plant mix.

Dust, smoke, or other contaminants shall be controlled at the plant site to meet all air quality requirements in the "Colorado Air Quality Control Act," Title 25, Article 7, CRS and regulations promulgated there under.

5.2 Hauling Equipment

Trucks used for hauling HMAP shall have tight, clean, smooth beds thinly coated with a minimum amount of paraffin oil, lime solution, or other approved release agent. Petroleum distillates such as kerosene or fuel oil will not be permitted. Each truck shall have a cover of canvas or other suitable material to protect the mixture from the weather and excessive temperature loss or cooled layers of mix in truck.

5.3 Bituminous Pavers

Self-propelled pavers shall be provided for full lane width paving, and shall be equipped with a screed assembly, heated if necessary, capable of spreading and finishing the bituminous plant mix material in full lane widths applicable to the typical section and thicknesses shown in the Contract. Pavers used for shoulders, patching and similar construction not requiring fine grade control shall be capable of spreading and finishing courses of asphalt plant mix material in widths shown in the Contract.

The paver shall have an automatic distribution system that will place and spread the mixture uniformly in front of the screed.

The paver shall be capable of operating at forward speeds consistent with uniform and continuous laying of the mixture. Stop and go operations of the paver shall be avoided. The screed or strike-off assembly shall produce the specified finished surface without tearing, shoving, or gouging the mixture. Self-propelled pavers shall be equipped with automatic screed controls with sensors capable of sensing grade from an outside reference line, and maintaining the screed at the specified longitudinal grade and transverse slope. The sensor shall be constructed to operate from either or both sides of the paver and shall be capable of working with the following devices when they are required for the situation:

- (1) Ski-type device at least 30 feet in length.
- (2) Short ski or short shoe.
- (3) At least 5,000 feet of control line and stakes.

The controls shall be capable of maintaining the screed at the specified transverse slope within plus or minus 0.1 percent. Automatic mode should be used where possible. If the automatic controls fail or malfunction the equipment may be operated manually for the remainder of the normal working day, provided specified results are obtained.

If the CONTRACTOR fails to obtain and maintain the specified surface tolerances, the paving operations shall be suspended until satisfactory corrections, repairs, or equipment replacements are made.



PART 6 EQUIPMENT MANUFACTURE

6.1 Preparation of Aggregates

Heating and drying of the aggregates shall be accomplished without damaging the aggregate. Lime shall be added to achieve complete and uniform coating of the aggregate. When hydrated lime is used it shall be added to the aggregate in accordance with one of the following methods:

- a). Lime Slurry Added to Aggregate: The hydrated lime shall be added to the aggregate in the form of a slurry and then thoroughly mixed in an approved pugmill. The slurry shall contain a minimum of 70 percent water by weight.
- b). Dry Lime Added to Wet Aggregate: The dry hydrated lime shall be added to wet aggregate (a minimum of three percent above saturated surface dry) and then thoroughly mixed in an approved pug mill.

The lime-aggregate mixture may be fed directly into the hot plant after mixing or it may be stockpiled for not more than 90 days before introduction into the plant for mixing with the asphalt cement. The hydrated lime may be added to different sized aggregates and stockpiled, by adding 75 percent of the lime to the aggregate passing the No.4 sieve and 25 percent to the aggregate retained on the No.4 sieve.

6.2 Mixing

The dried aggregates and asphalt cement shall be combined in the mixer in the quantities required to meet the design job mix. The materials shall be mixed until the aggregate is completely and uniformly coated, and the asphalt cement is uniformly distributed throughout the aggregate. Baghouse fines shall be fed back to the mixing plant in a uniform and continuous manner so as to maintain uniformity in the mixture. The Baghouse, fines feeder, auger, and related equipment, shall be in good working condition and operated in accordance with manufacturer's recommendation. If the TOWN determines that non-uniform operation of the equipment is detrimental to the mixture, he may halt all construction until the CONTRACTOR takes appropriate action.

The minimum temperature of the mixture when discharged from the mixer shall be as shown in the following table:

TABLE 6.2.1- MIXTURE DISCHARGE TEMPERATURES

Asphalt Grade	Minimum Discharge Temperature	Maximum Discharge Temperature
PG 58-28	275 °F	305 °F
PG 64-28	290 °F	320 °F
PG 78-28	320 °F	350 °F

HMAP mix shall be produced at the lowest temperature within the specified temperature range that produces a workable mix and provides for uniform coating of aggregates (95 percent minimum in accordance with AASHTO T 195), and that allows the required compaction to be achieved.

HMAP mix may be stored provided that any and all characteristics of the mixture are not altered by such storage. If storing or holding of the mixture causes segregation, excessive heat loss, or adversely affects the quality of the finished product, corrective action shall be taken. Unsuitable mixture shall be disposed of at the CONTRACTOR'S expense.

6.3 Hauling

Each truck shall use covers to protect the mix during transport in cold weather, dust storms or precipitation. The TOWN can reject mix which shows an excess or deficiency of asphalt cement, damage due to burning



or overheating, an improper gradation, or thermal segregation with cold areas 10° F below the minimum discharge temperature, the load shall be rejected.

PART 7 TACK COAT

Prior to placement of HMAP, a tack coat shall be applied to all existing concrete and asphalt surfaces. The material shall be in accordance with Section 2.4. The emulsified asphalt shall be diluted 1:1 with water and applied at 0.10 ± 0.01 gallons per square yard of diluted material. The TOWN may direct other application rates to match the age of condition of the surface.

The surface to receive the tack coat shall be dry and cleaned by sweeping or other approved method until dust, debris, and foreign matter are removed. The tack coat shall then be applied uniformly by squeegee, brooms, or distributor. Prior to paving, all water must have evaporated from the tack coat. Contaminated areas shall be cleaned and tack coat shall be re-applied.

PART 8 PLACEMENT

Hot mix asphalt shall be placed only on approved, properly constructed surfaces that are free from loose material, water, frost, snow or ice. The hot mix asphalt shall be placed in accordance with the temperature limitations of Table 8.1 and only when weather conditions permit the pavement to be properly placed and finished as determined by the TOWN. Placement temperature as stated shall be increased by 5 degrees F for each 10 miles per hour wind velocity to a maximum increased minimum placement temperature of 70 degrees

TABLE 8.1
MINIMUM AIR and SURFACE TEMPERATURES LIMITATIONS for MIX PLACEMENT

Compaction Layer Thickness	Top Layer of Pavement*		Lower Layers	
	PG 58-28 PG 64-28	PG 76-28	PG 58-28 PG 64-28	PG 76-28
<2 inches (not recommended)	60 °F	75 °F	N/A	N/A
2 inches to <3 inches	50 °F	65 °F	40 °F	50 °F
3 inches or more	50 °F	50 °F	40 °F	40 °F

* Air temperature is taken in the shade. Surface temperature is taken on the subgrade or base. The TOWN may not waive the above temperature limitations for PG 76-28.

The mixture shall not be placed at a temperature lower than 245 °F for mixes containing PG 58-28 or PG 64-28 asphalt, and 290 °F for mixes containing polymer modified asphalt. Mix which is too cold or damaged by weather will be rejected.

The mixture shall be laid upon an approved surface, spread and struck off to obtain the required grade and elevation after compaction. The minimum lift thickness shall be at least three times (preferably four times) the nominal particle size. The mixture should be placed approximately 25 percent thicker than the existing surrounding mat thickness to account for compaction. Raking is discouraged and will not be allowed except to correct major problems of grade and elevation. Casting or raking that causes any segregation will not be permitted.

On areas where the use of mechanical spreading and finishing equipment is impracticable, the mixture shall be carefully dumped, spread, raked, screeded, and luted by hand tools to the required compacted thickness plus 25 percent. Carefully move or minimally work the HMAP mix with the use of rakes, lutes, or shovels to avoid segregation. Mixtures made with modified asphalt cement require more rapid completion of handwork areas than for normal mixtures. Hauling and placement sequences shall be coordinated so that the paver is in constant motion. Excessive starting and stopping shall not be allowed. A construction joint shall be placed at any time the paver stops, and the screed drops enough to cause a surface dip in violation of Section 14.1,



Surface Tolerances; or the mat temperature falls below that allowed in Section 13.0, Compaction. Bituminous pavers shall be used to distribute the mixture either over the entire width or over such partial width as may be practicable. Echelon paving will be permitted.

PART 9 LONGITUDINAL JOINTS

9.1 Joint Placement

The longitudinal joints in both a new pavement and an overlay pavement layer shall offset the joint in the layer immediately below by a minimum of 6 inches. The joints in any pavement layer shall not fall in a wheel track or path. The joints in the top layer of new pavement not built on top of an existing pavement shall be located on lane lines, or as shown on the plans. Longitudinal joints shall be minimized where feasible with wide paving pulls or echelon paving. Joints shall not cross any centerline, lane line, or edge line unless approved by the TOWN.

The CONTRACTOR shall submit, prior to paving, a joint plan and pavement marking plan showing locations and the methods to field establish a control line. The TOWN must approve such plan prior to paving. The CONTRACTOR shall use a continuous string line to delineate longitudinal joints during paving as shown on the joint plan. All string line shall be removed at the end of each day's paving.

9.2 Joint Construction

All longitudinal joints shall be constructed using a 1-inch vertical face and a 3:1 taper. The free edge of the paved pass shall be laid as straight as possible, to the satisfaction of the TOWN. This joint, if cold, shall be tack coated prior to placement of adjacent paving.

The new compacted mat shall overlap the previously placed mat no more than 1.5 inches. Excess overlap or thickness shall not be raked or cast onto the new mat, but shall be wasted by pulling back and removing. The hot edge shall be blocked or bumped in a smooth line consistent with the previous longitudinal edge. Minor raking will only be allowed to correct major grade problems or provide mix around manholes and meter covers. The longitudinal joint shall be rolled from the hot side, and overlap the joint by approximately 6 inches on the cold side.

PART 10 TRANSVERSE JOINTS

The CONTRACTOR shall submit, prior to paving, a joint plan showing locations and the methods to be used to construct transverse joints. The TOWN must approve such plan prior to paving. Placing of the HMAP shall be continuous with a minimum of transverse joints, and rollers shall not pass over the unprotected end of a freshly laid mixture. Transverse joints shall be formed by cutting back on the previous run to expose the full depth of the course. Tack Coat material shall be applied to contact surfaces of all joints just before additional mixture is placed against the previously compacted material.

The end of transverse joints shall be located such that they will be constructed with a full head of mix in front of the screed. When butt joints are constructed, runoff boards shall be used to support the roller on the downstream side of the joint. All tapered sections, rounded edges and segregated areas shall be removed to achieve a vertical face at the butt joint before paving is restarted.

When a tapered joint is required for traffic access, the ramp shall be removed back to a full depth from segregated section before paving is restarted.

When restarting paving operations, the paver screed shall be placed on starter block on the completed side of the transverse joint. Starter block should be approximately 25% of the thickness of the existing completed mat, so that adequate grade and compaction can be achieved on starting the paving operation. The screed should be nulled (angle removed) when on starting blocks and an up angle of attack set. Proper head of mix should be introduced into the paver prior to starting. The new compacted (downstream) side of the joint may be up to 3/16 inches higher than the old (upstream) side. Raking of this joint shall not be allowed except to



correct major grade problems. The surface tolerance at the transverse joint must be verified with a 10-foot straight edge before the paver is more than 100 feet from the joint.

PART 11 SEGREGATION

The asphalt mixture shall be transported and placed on the roadway without segregation. All segregated areas shall be removed immediately and replaced with specification material before the initial rolling. If more than 50 square feet of segregated pavement is removed and replaced in any continuous 500 linear feet of paver width laydown, operations shall be discontinued until the source of the segregation has been determined and corrected.

The TOWN will visually determine areas that are segregated, and may also use density and gradation measures to help in this determination. The TOWN will visually determine the extent of the segregation. The CONTRACTOR will not be allowed additional compensation for correction of segregated areas.

PART 12 COMPACTION

The temperature of the mixture immediately behind the screed shall be at least 245 °F for PG 58-28 or PG 64-28 asphalt and 290 °F for PG 76-28 asphalt. The breakdown compaction shall be completed before the mixture temperature drops 20 °F.

The HMAP shall be compacted by rolling. The number, weight, and type of rollers furnished shall be that which is sufficient to obtain the required density and surface texture while the mixture is in a workable condition. Compaction shall begin immediately after the mixture is placed and be continued until the required density is obtained. Final compaction shall be obtained using steel wheel rollers.

If the required density is not achieved and the surface temperature falls below 145 °F, or there is obvious surface distress or breakage, no further compaction effort will be permitted unless approved by the TOWN. Price Reduction criteria in Section 15.0 shall still apply in such cases. The criteria for mixtures containing PG 76-28 asphalt cements shall be 235 °F. These minimum compaction temperatures may be adjusted according to the asphalt cement supplier recommendations. Adjusted minimum compaction temperatures must be shown on the approved mix design. Pavement operations shall be suspended when density requirements are not met, and the problem shall be resolved prior to continuing paving operations.

All roller marks shall be removed with the finish rolling. Use of vibratory rollers with the vibrator on will not be permitted on bridge decks .

The CONTRACTOR shall establish a rolling pattern or procedure during the beginning of paving operations which will achieve the required compaction and surface tolerances. This procedure may be re-evaluated by CONTRACTOR and TOWN throughout the paving operations.

All HMAP paving shall be compacted to between 92 and 96 percent of Maximum Theoretical (Rice) Density, (CP-51: Maximum Specific Gravity of Bituminous Paving Mixtures) with the average (mean) of five random and consecutive density tests equaling at least 93 percent of CP-51. If more than three random density tests fall below 93 percent of CP-51, corrective measures shall be taken by the CONTRACTOR. Compaction of less than 90 percent of CP-51 will be cause for removal and replacement. The average (mean) of the 3 most recent production CP-51 Rice values shall be used in calculating Relative Compaction according to CP-44.

The CONTRACTOR shall core the pavement if required by the TOWN for field density tests in accordance with Colorado Procedure 44, Method B (AASHTO T 230), or for field calibration of nuclear density equipment in accordance with the Appendix of Colorado Procedure 81 (ASTM D-2950). At a minimum, cores for nuclear density equipment calibration shall be taken at the beginning of placement of each pavement layer or change of mixture materials or gradation. Untested areas during placement will also require cores to be taken to verify compaction.



Along forms, curbs, headers, walls, and all other places not accessible to the rollers, the mixture shall be thoroughly compacted with mechanical tampers.

Any mixture that becomes loose and broken, mixed with dirt, or is in any way defective, shall be immediately removed and replaced with fresh hot mixture, and compacted to conform to the surrounding area.

PART 13 PRODUCTION TOLERANCES

13.1 Surface Tolerances

The variation between any two contacts with the surface shall not exceed 3/16 inch in 10 feet. Irregularities exceeding the specified tolerance shall be corrected at the CONTRACTOR'S expense. Transverse measurements for variations shall exclude breaks in the crown sections.

13.2 Job Mix Formula Tolerances

Production test results that deviate from the design job mix by more than the following are subject to PART 14.0:

TABLE 13.2.1 – JOB MIX FORMULA TOLERANCES

Item	
Passing No. 3/8" and Larger ¹	6%
Passing No.4 and No.8	5%
Passing No.30	4%
Passing No.50	3%
Passing No.200 ²	2%

¹ There is 1.0 percent tolerance for the maximum sieve size.

When disagreements concerning determination of specification compliance occur only valid tests from both the TOWN and CONTRACTOR will be considered. The TOWN shall determine validity. Generally, valid tests are those in which sampling and test have been performed according to referenced procedures and the results are within stated precision statements. When disagreements occur with Asphalt Content and gradation tests results, solvent extracted aggregate testing shall take precedence over burn-off oven extracted aggregate, which shall take precedent over cold feed belt testing.

PART 14 CONFORMITY WITH PLANS AND SPECIFICATIONS

All work performed and all materials furnished shall conform to the lines, grades, cross sections, dimensions, and material requirements, including tolerances, shown in the contract.

For those items of work where working tolerances are not specified, the CONTRACTOR shall perform the work in a manner consistent with reasonable and customary manufacturing and construction practices.

When the TOWN finds that the materials furnished, the work performed, or the finished product does not conform with the contract, but that reasonably acceptable work has been produced, the TOWN shall determine the extent of the work to be accepted and remain in place. Cost reduction, when allowed, shall be accomplished by adjusting pay quantities as indicated herein and applying contract unit prices to the reduced quantities. If accepted, the TOWN shall:

- A. Document the basis for acceptance by "Cure Notice" which shall provide for an appropriate adjustment in the payment quantity for such work or materials not otherwise provided for in this section.



- B. Notify the CONTRACTOR in writing that the payment shall be adjusted in accordance with this section when "P" is 25 or less.
- C. In lieu of cost (quantity) adjustment, permit correction or replacement of the finished product provided the correction or replacement does not adversely affect the work or the TOWN.

When the TOWN determines that the material furnished, work performed, or the finished product is not in conformity with the contract and has resulted in inferior or unsatisfactory product, the finished product or materials shall be removed and replaced or otherwise corrected by, and at the expense of, the CONTRACTOR.

Materials shall be sampled and tested by a qualified Testing Laboratory in accordance with the sampling, testing schedules, and procedures contained in the Section 15.0, Testing and Inspection. The approximate maximum quantity represented by each sample shall be as set forth in the testing schedule. An additional number of samples, in relation to the quantity of materials represented, may be selected and tested at the TOWN'S discretion. The quantity represented by five consecutive random samples shall constitute a lot, whenever production schedules and material continuity permits. When, it is necessary to represent short production runs, significant material changes, or other unusual characteristics of the work, the TOWN may establish a lot consisting of the quantity represented by any number of consecutive random samples from one to seven inclusive. Testing results that are determined to have sampling or testing errors, as determined by the TOWN, shall not be used.

Materials or work shall only be evaluated for price adjustment when deviations from specifications occur on any of the individual tests for the lot. The several individual test values shall be averaged and the percentage of cost (quantity) reduction for the lot shall be determined by applicable formula. This shall apply only when a cost reduction factor for the element is listed in Table 14.1. The formula in (a) and (b) below shall be used only when the lot is represented by three to seven tests inclusive.

- a) $P = (X_n + aR - T_u) * F$ Shall be used if a maximum limit only is specified or; when the average of the several test values is above the mid point of the specification band or above the job-mix formula value.
- b) $P = (T_L + aR - X_n) * F$ Shall be used if the minimum limit only is specified or; when the average of the several test values is below the mid point of the specification band or below the job-mix formula value.
- c) When the lot is represented by fewer than three tests, the materials shall be evaluated for cost (quantity) reduction by the following procedure: Lots represented by two tests shall be divided into two separate lots represented by one test each, as determined by the TOWN. Each lot that deviates from the specifications shall be cost adjusted by one of the following formulae.

$P = 0.76 * (T_o - T_u) * F$ When a maximum limit only is specified or the test value is above the maximum specified limit.

$P = 0.76 * (T_L - T_o) * F$ When a minimum limit only is specified or the test value is below the minimum specified limit.

Where:

P is the percentage of reduction in payment quantity.

X_n is the average of the several test values from samples taken from the lot, with "n" indicating the number of values.



a is a variable factor to be used in “n” changes according to the following:

when “n” is	“a” equals
3	0.45
4	0.38
5	0.33
6	0.30
7 or greater	0.28

R is the difference between the highest and lowest values in the group of several test results from the lot.

T_u is the upper or maximum tolerance limit permitted by the specifications.

T_L is the lower or minimum tolerance limit permitted by the specifications.

T_o is the test value of the test that deviates from the specifications.

F is the cost reduction factor to be applied for each element as shown in the following table:

TABLE 14.1

TABLE OF PRICE REDUCTION FACTORS	
ELEMENT	FACTOR “F”
100 percent size sieve	1
½-inch sieve and larger	1
No. 100 sieve to 3/8-inch sieve inclusive (except 100 percent size sieve)	3
No. 200 sieve	6
Density of Bituminous mixture	8
Asphaltic Cement content (all asphalt-aggregate mixtures)	20
Total air voids	30
Voids in mineral aggregate	20
Stability	5

If “P” is less than ten, or a negative quantity, the material shall be accepted as being in conformity. In cases where one or more elements show a positive “P” value, such positive values shall be added and the resulting sum shall be used to determine whether the material is in conformity. If the total “P” value is between 10 and 25, the TOWN may require correction or may accept the material at a reduced cost. If “P” is greater than 25, the TOWN may: 1) require complete removal and replacement with specification material at no additional cost to the TOWN; 2) require corrective action to bring the material into conformity at no additional cost to the TOWN; 3) where finished product is found to be capable of performing the intended purpose and the value of the finished product is not affected, permit the CONTRACTOR to leave the material in place with an appropriate cost adjustment to be based on the TOWN’S evaluation but not to be less than that which would have occurred had an adjustment been made where “P” = 25.

When aggregate sieve analysis for aggregate base course deviates from the specification requirements and the total “P” is three or greater, the reduction shall apply to the contract cost (quantity) multiplied by 0.60.

If asphaltic cement content, aggregate sieve analysis, or compaction deviates from the specification requirements and the total “P” is three or greater, the reduction shall apply to the contract cost (quantity)



multiplied by 0.60 for aggregate base course and Hot Bituminous Pavement mixtures.

Cost adjustment for those elements that are not included in the Table of Price Reduction Factors shall be determined by the TOWN.

The CONTRACTOR shall not have the option of accepting a cost reduction in lieu of producing specification material. Continued production of non-specification material shall not be permitted. Material that is defective as identified by visual inspection shall be isolated and rejected without regard to sampling sequence or location within a lot.

For Thickness Deficiencies: If the cores indicate a thickness deficiency additional cores will be taken so that price reductions are per Lot, based upon a Lot encompassing 300 lineal lane feet or the quantity between tests, and shall be at the unit cost of the HMAP. The following chart is for new construction only. It is not to be used for overlays.

TABLE 14.2- PRICE REDUCTION –THICKNESS

HMAP Thickness	0%	25%	Reject	
Thickness Deficiency	0 – 0.25"	0.25" – 0.50"	>0.50	➤

PART 15 TESTING AND INSPECTION

If any materials furnished or work performed by the contractor fails to fulfill the specification requirements, such deficiencies shall be reported to the Project Manager and the Contractor immediately. Preliminary written field reports of all tests taken and observation results shall be given to the Contractor or Developer immediately after they are performed. Field reports shall be forwarded to the Project Manager no later than 1 week following the testing.

Reports of all tests taken, including failing tests, shall be reported to the TOWN to the Developer and to the Contractor no later than 24 hours following the sampling. Density test results will be given in writing at the time the testing occurs.

Testing of Hot Mix Asphalt Pavement shall be performed in accordance with Table 15.1. The tests shall be performed under the general supervision of and signed by a professional engineer registered in the state of Colorado. Technicians taking samples and conducting compaction tests must have a LABCAT Level A certification or equivalent. Technicians conducting tests of asphalt content and gradation must have a LABCAT Level B certification or equivalent. Technicians performing voids testing must have a LABCAT Level C certification or equivalent.



TABLE 15.1
SCHEDULE FOR MINIMUM MATERIALS SAMPLING AND TESTING

Test	Standard	Minimum Frequency
Sampling	AASHTO T168, ASTM D 979 and ASTM D3665	One test for each day
Density	CP-44, CP-81, CP-82	One test for each 300 Lineal Feet per Lane
Thickness (Core)	ASTM D3549	One test for each 300 Lineal Feet per Lane, 2 minimum
Gradation	CP-31A, CP-31B	One test for each day
Asphalt (AC) Content	CP-L 5120 or AASHTO T 164 or other methods agreed upon between TOWN and CONTRACTOR	One test for each day
Maximum Theoretical Specific Gravity (Rice)	CP-51	One test for each day
Lottman Stripping, TSR & Dry Density	CP-L 5109, Method B	Lime additive pavements only
Asphalt Binder	AASHTO MP1, PG 64-28 or equal	One per tanker

Inspectors shall be responsible for checking temperatures of mix in truck and on pavement, segregation, rolling patterns and other construction means and method which affect the performance of the pavement system. The CONTRACTOR shall provide assistance in sampling and testing at all facilities and at the job site.

PART 16 MEASUREMENT AND PAYMENT

HBP will be measured and paid for at the Bid Unit Price per s.y. or ton per CDOT Section 403. Provisions of CDOT Section 109.01, Measurement of Quantities, shall apply. The Unit Bid price for HBP shall include the costs for applying bituminous tack coat material at the proper application rate. No separate measurement or payment for tack coat will be made.

<u>Description</u>	<u>Payment</u>
HBP	\$/s.y.
HBP	\$/ton



SECTION 2616
PAVEMENT REMOVAL AND REPLACEMENT

PART 1 GENERAL

DESCRIPTION

Work included:

1. Protection of existing pavement.
2. Removal and replacement of pavement structure which may include surface, base, and subbase courses as required for trench, and test hole excavation or as otherwise required by the Engineer.
3. Installation, and removal of temporary pavement structure consisting of base course.

1.2 QUALITY ASSURANCE

- A. Refer to Sections 401.01 to 401.20 of the current edition of the Standard Specifications for Road and Bridge Construction, CDOT, State of Colorado herein called Standard Specifications.
- B. Only contractors with proven experience in the type of work to be performed shall be allowed to construct bituminous pavements.
- C. The Contractor shall conduct compaction tests as necessary to monitor the installation procedure and assure the quality of the work.

1.3 SUBMITTALS

- A. Submit references and proof of experience to Engineer prior to scheduling installation of bituminous pavement.
- B. Submit method of cutting and removing pavement as well as equipment and method to be used for pavement replacement.

PART 2 PRODUCTS

- A. Base Course (Surface Course for Gravel Roads): $\frac{3}{4}$ -inch minus. Class 6 Aggregate Base Course per Section 703 of the Standard Specifications.
- B. Surface Course: Bituminous pavement shall meet the requirements of Sections 401.01 to 401.06 of the Standard Specifications, $\frac{3}{4}$ -inch mix made with 6 percent of AC-10

PART 3 EXECUTION

3.1 PROTECTION OF EXISTING PAVEMENT

The pavement adjacent to an excavation shall be protected from damage caused by movement of construction equipment or other Work. Planking, mats or other appropriate means of protection shall be used. Any paved surface damaged due to the Contractor's negligence, shall be replaced or repaired at no expense to the Owner. The area to be replaced or repaired shall be as designated by the Engineer.



3.2 CUTTING AND REMOVAL

Pavement shall be neatly cut along the lines shown on the Drawings or as approved in the field by the Engineer. Pavement shall be cut by saw, or other approved method.

Care shall be exercised so that adjacent pavement outside the cut will not be disturbed or damaged. Excavated pavement shall be removed and disposed of off-site. Removed pavement may not be used as trench backfill.

3.3 BASE COURSE (SURFACE COURSE FOR GRAVEL ROADS)

Construct a base course section compacted to 95 percent in lifts not to exceed 6 inches. The top of the section shall be the bottom of the bituminous pavement section. In gravel roads the top of the section shall be the traveled surface. The thickness of the base course section shall be 12 inches unless directed otherwise.

3.4 TEMPORARY PAVEMENT

If bituminous pavement is not replaced within 24 hours following backfill completion, the Contractor shall install additional base course to match the existing traveled surface. The Contractor shall maintain the traveled surface as necessary to keep it smooth, free from soft spots and dust free. Just prior to bituminous pavement replacement, the Contractor shall remove and dispose of the additional base course.

3.5 BITUMINOUS PAVEMENT REPLACEMENT

Prior to installation of bituminous pavement, cut and remove additional pavement per 3.2 above to provide a clean, straight and uniform line without sharp jogs.

Replaced pavement shall be 4 inches minimum thickness placed in two equal lifts and compacted to 95 percent of maximum density. Pavement shall be placed in accordance with the appropriate requirements of Section 401.07 to 401.20 of the Standard Specification.

3.6 FIELD QUALITY CONTROL

The degree of compaction specified for non-bituminous material shall be percent of maximum dry density as determined by ASTM D 1557, Modified Proctor.

The moisture content of non-bituminous material shall be within 2.0 percent of optimum moisture as determined by ASTM D 1557.

Testing frequency shall be as required to assure the completed work meets specifications but shall be no less than the following:

An average of one test per type of material placed per 100 feet of trench

PART 4 MEASUREMENT AND PAYMENT

PAVEMENT REMOVAL AND REPLACEMENT

- A. Along Bituminous Pavement Surfaced Trenches: will be measured and paid for at the Unit Price per Square Yard under the item Pavement Removal and Replacement Along Bit Pavement Surfaced Trenches based upon bituminous pavement thickness and base course thickness. Payment width shall be the actual width of bituminous pavement installed not to exceed the Maximum Pavement Replacement Paywidth shown on the Drawings. The length measurement



shall be the actual length of the patch measured through manholes. Where trenches intersect the length of the intersecting patch shall not be included in the measurement.

Payment shall include protection of existing pavement, cutting excavation and removal of the pavement structure; installation of base courses, installation and removal of temporary pavement, installation of bituminous pavement and all other incidental materials or Work required.

- B. Along Gravel Surfaced Trenches: will be measured and paid for at the Unit Price per Square Yard under the item Pavement Removal and Replacement Along Gravel Surfaced Trenches per base course thickness. Payment width shall be the backfill zone paywidth as shown on the Drawings. The length measurement shall be the actual length of the trench measured through manholes. Where trenches intersect the length of the intersecting trench shall not be included in the measurement.

Payment shall include protection of existing pavement, excavation and removal of the pavement structure, installation of base courses, and all other incidental materials or Work required.

- C. At Miscellaneous Bituminous Pavement Surfaced Locations: such as at test holes or other locations designated by the Engineer. Measurement and payment for the bituminous pavement to exclude base course material will be at the Unit Price per Square Yard under the item Pavement Removal and Replacement as Directed based upon bituminous pavement thickness and actual square yards in place.

Payment shall include protection of existing pavement; cutting, excavation and removal of the pavement structure; installation and removal of temporary pavement; installation of bituminous pavement and all other incidental materials or Work required.

- D. At Miscellaneous Gravel Surfaced Locations: such as at test holes or other locations designated by the Engineer. Measurement and payment for the base, to include base course material beneath Miscellaneous Bituminous Pavement Surfaced Locations per C. above, will be at the Unit Price per Cubic Yard under the item Pavement Removal and Replacement as Directed 3/4" Minus Base Course per actual cubic yards installed measured in place excluding the volume of base course material for temporary pavement.

Payment shall include protection of existing pavement; excavation and removal of the pavement structure or other unsuitable material authorized by the Engineer; installation of base course, and all other incidental materials or Work required.



SECTION 2620
CURB, GUTTER, SIDEWALK AND
CONCRETE PAVEMENT TRAIL SURFACES

PART 1 GENERAL

1.1 DESCRIPTION

Work included: This specification shall govern all labor, materials, equipment and services which are required for the installation of curbs, gutter, sidewalk and concrete trail surfaces.

1.2 QUALITY ASSURANCE

A. Standards: Comply with standards specified in this Section, except as herein after modified.

1. CRSI "Manual of Standard Practice".
2. ACI 304 "Recommended Practice for Measuring, Mixing, Transporting and Placing Concrete".
3. ACI 305 "Hot Weather Concreting".
4. ACI 306 "Cold Weather Concreting".
5. ACI 308 "Standard Practice for Curing Concrete."
6. ACI 309 "Standard Practice for Consolidation of Concrete".
7. ACI 347 "Recommended Practice for Concrete Formwork"

In case of conflict between the referenced standards, the more stringent requirements shall govern.

B. Qualifications of installers: Throughout the progress of installation of the work of this Section, provide at least 1 person who shall be thoroughly familiar with the specified requirements, completely trained and experienced in the necessary skills, and who shall be present at the site and shall direct all work performed under this Section.

In actual installation of the work of this Section, use adequate numbers of skilled workmen to ensure installation in strict accordance with the approved design.

In acceptance or rejection of work performed under this Section, the Engineer will make no allowance for lack of skill on the part of workmen.

C. Quality control: Prior to all work under this Section, make all necessary arrangements with the testing laboratory. The testing laboratory shall be able to furnish the following upon request:

1. Test, and furnish certified reports on:
 - a. Proposed aggregates.
 - b. Proposed cements.
 - c. Mixing water.
2. Prepare design mixes for each type of concrete, using previously tested and approved materials. These mix designs shall be prepared under the supervision of a concrete technologist experienced in the special considerations of materials and mixes.
3. Proportion mixes by either laboratory trial batch or field experience methods, using materials to be employed on the work for each class of concrete required.
 - a. Complete identification of aggregate source of supply;
 - b. Results of tests of aggregates for compliance with specified requirements.
 - c. Scale weight of each aggregate.
 - d. Absorbed water in each aggregate.
 - e. Brand, type, chemistry, and physical test for each cement.



- f. Brand, type, and amount of each admixture.
 - g. Amounts of water used in trial mixes.
 - h. Proportions of each material per cu. yd.
 - i. Gross weight and yield per cu. yd. of trial mixes.
 - j. Measured slump.
 - k. Measured air content.
 - l. Compressive strength developed at 1 day, 3 days, 7 days, and 28 days, from not less than 3 test cylinders cast for each 1, 3, 7, and 28-day test, and for each design mix.
4. Furnish certified reports of each proposed mix for each type of concrete at least 7 days prior to start of installation of the work of this Section.
5. All concrete for cast on site work for this project shall have the following properties:

Compressive strength	4,000 psi in 28 days
Maximum coarse aggregate size	3/4"
Maximum fine aggregate size	3/8"
Minimum cement factor	6 sacks/cubic yard
Air content	4 – 8% by volume
Slump (on site)	4" maximum
Fiber (Fibermesh)	Per manufacturer recommendation

Do not begin concrete production until all mixes have been reviewed and approved by the Engineer.

For exposed fine aggregate concrete (Type II Finish) maximum size aggregate shall be 3/8" and shall comply with "Fine Aggregate" gradation. Aggregate shall have a variety of color and approved prior to use.

- D. Finished Product: Shall be in close conformity with lines, grades, and typical cross sections shown on the Drawings, as required to match existing adjacent sidewalk, or as established by the Engineer.

1.3 SUBMITTALS

- A. General: Comply with provisions of Section 1300.
- B. Product data: Within 14 calendar days after award of Contract.
- 1. Complete information on proposed consolidation equipment;
 - 2. Complete description of proposed curing methods;
 - 3. Concrete mix designs, prepared in accordance with the provisions of subparagraph 1.2 C above.

1.4 PRODUCT HANDLING

- A. Protection: Use all means necessary to protect the materials of this Section before, during, and after installation and to protect the work and materials of all other trades.
- B. Replacements: In the event of damage, immediately make all repairs and replacements necessary to the approval of the Engineer and at no additional cost to the Owner.



PART 2 PRODUCTS

2.1 CEMENT

- A. General: Cement shall be Type I or Type II Portland cement conforming to the requirements of ASTM C 150 "Standard Specifications for Portland Cement", unless otherwise specifically modified on the drawings.
- B. Sequence of use: Use only one brand of cement for the entire work and use in the same sequence as received at the site.

2.2 AGGREGATES

- A. General: All aggregates shall conform to requirements of ASTM C 33, except as modified below.
- B. Coarse and fine aggregate: Aggregate shall comply with ASTM C 33 "Standard Specifications for Concrete Aggregates".
- C. Aggregate sources: Provide aggregates from one source of supply only.
- D. Aggregate sizes: Maximum aggregate size shall be not larger than 1/5 of the narrowest dimension between sides of forms, nor 3/4 of the minimum clear spacing between individual reinforcing bars or bundles of bars.
 - 1. Fine aggregate: shall meet the following grading requirements.

<u>Sieve size</u>	<u>% passing</u>
3/8"	100
No. 4	95-100
No. 16	45-80
No. 50	10-30
No. 100	2-10
No. 200	0-3

- 2. Coarse aggregate: shall meet the following grading requirements.

<u>Sieve size</u>	<u>% passing</u>
1"	100
3/4"	95-100
3/8"	20-55
No. 4	0-15
No. 8	0-3

- E. Stockpile the aggregates in a manner to protect from contamination.

2.3 WATER

Water used as an ingredient in concrete shall be clean, potable, and free from injurious amounts of foreign matter or other substances that may be deleterious to concrete or reinforcement.



2.4 CONCRETE ADMIXTURES

- A. General: All admixtures shall be as follows:
 - 1. Air-entraining admixtures, Comply with ASTM C 260.
 - 2. Water reducing admixtures, Comply with ASTM C 494 - Type A
 - 3. Water reducing/retarding, Comply with ASTM C 494 - Type D
 - 4. Other admixtures shall conform to ASTM C 494 unless specific approval is secured before starting mix design procedures.
- B. Acceptable substitutes: The Engineer will only consider those proposed admixture substitutions which have been completely tested and reported upon by the testing laboratory in accordance with the provisions of subparagraph 1.2 C above.
- C. Calcium chloride: Addition of calcium chloride to the concrete mix at the batch plant or at the job site will not be allowed.

2.5 CURING MATERIALS

- A. Burlap cloth made from jute or kenaf and weighing approximately 9 ounces per square yard for moist curing shall conform to AASHTO M 182. Use 2 layers and stagger joints.
- B. Sheet materials for curing concrete shall conform to ASTM C 171. Plastic sheeting shall be a minimum thickness of 6 mil, colored white.
- C. Liquid curing and sealing compounds shall be a clear membrane-forming compound conforming to ASTM C 309.

2.6 JOINT FILLERS

Preformed expansion joint filler material shall be bituminous fiber type conforming to ASTM D 1751. Filler for each joint shall be furnished in a single piece for the full depth and thickness required.

Poured joint filler shall be a silicone sealant per CDOT M-412-1.

2.7 DOWELS AND SCREED KEY JOINTS

Dowels shall be smooth ASTM A615, Grade 60 or round ASTM A 36 bar.
Screed Key Joints may be substituted for Dowels if approved by the Town.

2.8 FORM MATERIALS

- A. Forms: Construct formwork for exposed (painted or unpainted) concrete surfaces with smooth faced undamaged plywood or steel or other panel type material acceptable to the Engineer, to provide continuous, straight, smooth as-cast surfaces. Furnish in largest practicable sizes to minimize number of joints.

Construct formwork for concrete concealed from view as indicated above. Less attention may be given to condition of plywood and other appearance considerations, except that bowed, unstable and leaky formwork will not be tolerated.

Provide form material with sufficient thickness to withstand pressure of newly placed concrete without excessive and objectionable bow or deflection.

Bender boards with adequate supports shall be used on all trail concrete with curves of less than 75 foot radius.



- B. Form coatings: Provide commercial formulation form-coating compounds that will not bond with, stain, nor adversely affect concrete surfaces requiring bond or adhesion, nor impede the wetting of surfaces to be cured with water or curing compounds.

2.9 GROUT

Grout shall be a nonshrink, ready-to-use, non-metallic aggregate product requiring only the addition of water at the job site, and shall have the following attributes:

- A. Be capable of producing a flowable grouting material having no drying shrinkage or settlement at any age.
- B. The compressive strength of grout 2" cubes shall be no less than 5,000 psi at age 7 days, and 7,500 psi at age 28 days.

Store, mix, and place the nonshrink grout in strict accordance with manufacturer's recommendations as approved by the Engineer.

2.10 BATCHING, MIXING, AND DELIVERY EQUIPMENT

Use ready-mixed concrete from approved batching and mixing plant. Batch, mix and transport concrete to site in accordance with provisions of ASTM C 94.

2.11 UTILITY CONDUIT

Utility conduits shall be Schedule 80 PVC.

2.12 FIBROUS CONCRETE REINFORCEMENT

- A. General: Use 100 percent virgin polypropylene, fibrillated fibers containing no reprocessed olefin materials and specifically manufactured for use as concrete reinforcement. Fibrous concrete reinforcement shall be manufactured by Fibermesh Company, 4019 Industry Drive, Chattanooga, TN 37416, or approved equal.
- B. Physical Characteristics:
 - 1. Specific Gravity, 0.91
 - 2. Tensile Strength, 70 - 110 ksi
 - 3. Fiber Length, 1/2", 3/4", 1 1/2", 2" per manufacturer

2.13 BED COURSE

Bed Course shall be Road Aggregate Base Course material per the Gravel Surfacing Section.

PART 3 EXECUTION

3.1 REMOVAL OF EXISTING CURB AND GUTTER AND SIDEWALK

- A. Sawcutting: Where removal is required for reconstruction or replacement with concrete or paving stone, the existing concrete section shall be saw cut with an abrasive type saw and carefully removed. Saw cuts shall be done to the proper lines to permit placement of new concrete surfaces or paving stones as shown on the Drawings or as directed by the Engineer. Saw cuts shall not deviate from established lines by more than 1/4 inch. Cuts for appurtenances such as grates must be of adequate size and proper configuration to allow placement of the appurtenance.



- B. Haul Away: The Contractor shall be responsible for haul away and disposal of all removed curb and sidewalk materials to an off-site waste area.

3.2 SUBGRADE PREPARATION - TRAILS

Refer to Section 2211

3.3 SUBGRADE PREPARATION - CURB, GUTTER AND SIDEWALKS

- A. Excavation: The excavation shall be made to the required depth to permit the installation of the paved surface including bed course materials, and to the required width to allow for installation and bracing of forms. The foundation shall be shaped and compacted to a firm, even surface conforming to the section shown on the plans or as staked.
- B. Soft Spot Repair: All soft and yielding subgrade soils shall be removed and replaced with compacted imported fill materials as directed by the Engineer. A minimum of 12 inches of native material shall be removed. Stabilization fabric shall be placed over the native materials prior to placing imported fill.
- C. Overexcavation: Any accidental overexcavation made by the Contractor shall be replaced with suitable fill and recompact to 95% of maximum density as determined by ASTM D-1557.
- D. Fill: All areas beneath the paved surface requiring imported fill shall be filled with base course or pit run materials compacted to a minimum of 95% of maximum density as determined by ASTM D-1557. Any paved surface that settles in the vicinity of fill areas during the one-year warranty period shall be replaced by the Contractor as a warranty item.
- E. Bed Course: A 4-inch thick layer of bed course materials shall be placed beneath the paved surface. Where the existing subgrade consists of stable, granular material, the Engineer may delete the requirement for placement of bed course material prior to making the excavation. The bed course material shall be compacted to 95 percent of maximum density and shaped to a smooth surface to conform with required concrete section.
- F. Haul Away: The Contractor shall be responsible for haul away and disposal of all unsuitable and excess materials requiring removal from the Work area.

3.4 FORMWORK

- A. Typical Section: All concrete curb and gutter and trail shall conform to the typical sections shown on the Drawings or as described in the Specifications.
- B. Line and Grade: New trail surfaces shall match the existing adjacent sidewalk grade unless otherwise directed.
- C. Grades and Drainage: All flow lines of gutters shall have positive drainage to inlets or curb ending points. Positive drainage shall be defined as a grade of at least 0.3 percent along all sections of the curb. Any low spots in the flow line of the curb and gutter which cause water to stand to a depth greater than 1/4", or low spots in the backslope of the pan which permit water to escape the flow line and flow across streets, shall be removed and replaced at the Contractor's expense. All curb and gutter of questionable slope shall be tested by the Contractor by flowing water in the gutter line in the presence of the Engineer.

All forms shall be checked by the Contractor with an appropriate leveling device prior to concrete placement to assure that the requirement for positive drainage is met. Errors in staking or calculation of cuts by the Engineer shall not relieve the Contractor of the positive drainage requirement. Upon discovery of such errors the Contractor shall immediately notify the Engineer so he may remedy the problem. Concrete shall not be placed until such grade problems are resolved.



- D. Forms: Forms shall be smooth on the side placed next to the concrete, and shall have a true smooth upper edge and shall be rigid enough to withstand the pressure of fresh concrete without distortion. All forms shall be thoroughly cleaned and coated with form oil to prevent the concrete from adhering to them. The depth of forms shall be equal to the full depth of the concrete to be placed. Forms shall be carefully set to alignment and grade and shall conform to the required dimensions. Forms shall be held rigidly in place by stakes. Clamps, spreaders, and braces shall be used where required to insure rigidity in the forms. Benders or thin plank forms shall be used on curves, grade changes, or for curb returns. Back forms for curb returns may be made of 1/2" thick benders cleated together for the full depth of the curb. The form on the front of curbs shall not be removed in less than one hour nor more than 6 hours after the concrete has been placed. In no event shall forms be removed while the concrete is sufficiently plastic to slump.

3.5 DOWEL AND SCREED KEY JOINTS INSTALLATION – TRAILS

Screed Key Joints installation details must be approved by the Town.

- A. Smooth dowel bars shall be placed in the forms at each expansion and contraction joint. One-half of the dowel length shall be coated with a bond breaker of lead or tar paint or other approved covering. Joints must be laid out and marked on forms such that contraction joints align properly with dowels.
- B. Dowels shall be made up in "dowel baskets", or other approved assembly, such that dowels can be set level and parallel to one another and parallel to the length of the slab. "Dowel basket" assemblies must be anchored to the subgrade to prevent movement during concrete placement. Placement tolerance for dowels shall be per CDOT standard M-412-1.

3.6 CONCRETE PLACEMENT

- A. General: Place concrete in compliance with practices and recommendations of ACI 304, and as herein specified.
- B. Procedures: Do not place concrete on frozen, muddy or saturated soil, or into standing water. Deposit concrete continuously or in layers of such thickness that no concrete will be placed on concrete which has hardened sufficiently to cause the formation of seams or planes of weakness within the section. The subgrade should be moist at the time of concrete placement. If necessary it should be dampened with water in advance of concreting.

If a section cannot be placed continuously, provide construction joints with expansion material as herein specified and as approved by the Engineer.

Deposit concrete as nearly as practicable in its final location to avoid segregation due to rehandling and flowing. Do not subject concrete to any procedure which will cause segregation.

Screed concrete which is to receive other construction to the proper level and avoid excessive skimming and grouting.

Do not use concrete which becomes non-plastic and unworkable, or does not meet the required quality control limits, or which has been contaminated by foreign materials, or has remained in the concrete truck for over 1 hour.

Remove rejected concrete from the site and dispose of it in a location approved by the Engineer for that purpose.



- C. Routine testing to determine the acceptability of the concrete will be performed by the Contractor through an approved testing laboratory. These tests will include the following:

1. Slump: As per ASTM C 143.
2. Air Entrainment: As per ASTM C 173 or C 231.
3. Compressive Strength: As per ASTM C 31 and C 39.

Minimum testing will consist of the performance of the above tests, including the taking of 4 concrete cylinders for each 100 cubic yards, or fraction thereof, placed in any one day.

Cylinders shall be broken as follows: 1 cylinder at 7 days; 2 cylinders at 28 days

The remaining cylinder shall be retained for breaking at a later date, as directed by the Engineer.

The Contractor shall notify the Engineer of the time and amount of an anticipated pour at least 24 hours in advance to allow the Engineer to schedule testing and sampling. The Contractor shall assist the Engineer with sampling as required.

Early form removal, early backfilling, or other unusual construction practices will require verification of concrete strength through the casting of additional test cylinders. The cost of additional cylinders shall be at the Contractor's expense. The Contractor shall notify the Engineer at least 48 hours prior to a pour of the need for additional cylinders.

Should any concrete fail to meet the standards of these Specifications, the concrete in question may be rejected, and changes in proportions of materials may be required by the Engineer. Additional testing required as a result shall be at the Contractor's expense.

- D. Concrete conveying: Handle concrete from the point of delivery and transfer to the concrete conveying equipment, and to the locations of final deposit, as rapidly as practicable and by methods which will prevent segregation and loss of concrete mix materials.

Provide runways for wheeled concrete conveying equipment from the concrete delivery point to the locations of final deposit.

Keep interior surfaces of conveying equipment, including chutes and tremies, free from hardened concrete, debris, water, and other deleterious materials.

Pumps may be used only if they can pump the mix designed. Do not add fine aggregate or water to the mix to satisfy needs of a pumping device.

Use chutes or tremies for placing concrete where a drop of more than 60 inches is required.

- E. Placing concrete: Deposit and consolidate concrete in a continuous operation, within the limits of construction joints, until the placing of a panel or section is completed.

Bring slab surfaces to the correct level with a straight edge, and then strike off.

Use bullfloats or darbies to smooth the surface, leaving it free from bumps and hollows.

Do not sprinkle water on the plastic surface. Do not disturb the slab surfaces prior to start of finishing operations.

- F. Cold weather placing: Comply with ACI 306 to protect all concrete work from physical damage and reduced strength which would be caused by frost, freezing actions, or low temperatures.



- G. Hot weather placing: Comply with ACI 305, when hot weather conditions exist which would seriously impair the quality and strength of concrete.
- H. Weather Limitations: Unless adequate protection is provided and approved by the Engineer, concrete shall not be placed during rain, sleet or snowfall. Concrete shall not be placed when the temperature is 40 degrees Fahrenheit or below, except with the written authorization of the Engineer. In no case shall concrete be deposited on a frozen subgrade. Any concrete poured when the temperature is below 40 degrees Fahrenheit shall be at the Contractor's risk, regardless of any written authorization. Adequate precautions shall be taken for such protection of all concrete after it is placed in position as well as prevent the temperature of the deposited concrete from falling below 40 degrees Fahrenheit for seven days. A sufficient supply of insulation blankets for covering or protecting the concrete shall be provided on the work and spread to a depth necessary to prevent freezing.

3.7 CONSOLIDATION

- A. General: Consolidate all concrete in accordance with provisions of ACI 309.

During all phases of operation, maintain a frequency of not less than 10,000 vibrations per minute per internal vibrator.

Do not vibrate forms or reinforcement. Do not use vibrators to transport concrete horizontally inside the forms.

- B. Equipment: Provide adequate number of units and power source at all times. Maintain spare units on hand to ensure adequacy. Under ordinary conditions, concrete for trail surfaces shall be struck-off and consolidated by means of a truss type vibrating screed machine, Allen Engineering Corporation "Razorback Screed" or approved equal. The Contractor shall provide a submittal on the machine for the Engineer's review and approval. Alternate types of mechanical vibration equipment shall be required in areas not accessible to the vibrating screed type machine.

If, in the opinion of the Engineer, the equipment being used is not adequate to accomplish proper consolidation, the Engineer may order delay in further placement of concrete until such equipment is available for use at the location of placement of concrete.

- C. Procedures: Limit duration of vibration to time necessary to produce satisfactory consolidation without causing segregation of aggregates.

Spacing between insertions of the vibrator which is used to consolidate shall not exceed twice the radius of action as shown in table 5.1.4 of ACI 309.

Under no circumstances shall the points of insertion during the consolidation phase be more than 18" apart.

3.8 JOINTS

Contraction joints, 1/8-inch wide, shall be constructed at the intervals noted on the Drawings or as directed by the Engineer. When Portland Cement concrete pavement is adjacent thereto, or to be constructed adjacent thereto, the joints shall coincide with the contraction joints in the adjacent pavement. Contraction joints shall be placed equal to the width of trail or sidewalk installed if not directed or specified otherwise. The joints shall be constructed to a minimum depth of 1/3 the concrete depth by saw cutting. Cutting shall commence after the concrete is sufficiently hard so that the blade does not dislodge aggregate and that the edges of the cut do not ravel, and shall be done within 12 hours of finishing. Where saw cuts abut other construction, the length of the proposed cut which can not be sawn shall be tooled out from the obstruction the required distance. Slabs that experience shrinkage cracking due to inadequate joint depth or due to untimely and improper saw cutting shall be removed and replaced at no cost to the Owner.



Expansion joints, ½-inch wide, by full slab depth, shall be installed at each side of structures, at ends of curb returns, at all curb ramps, at 25-foot intervals along curbs, at maximum 100 foot intervals along trail slabs, to match existing expansion joints or as directed by the Engineer. Expansion joints shall consist of preformed joint filler conforming to the provisions herein.

At both contraction and expansion joints in trail surfaces, install smooth dowel bars.

Isolation joints shall be formed around all appurtenances such as manholes, utility poles, etc., extending into and through the trail or curb. Preformed expansion joint filler ¼-inch thick shall be installed in these joints. The Contractor shall attempt to locate expansion or contraction joints to intersect isolation joints in a symmetrical manner.

3.9 FINISHING

- A. Type I Finish (Brush Finish): The surface shall be finished with a wooden or magnesium float. No plastering of the surface will be permitted. All outside edges of the slab shall be edged with a ½-inch radius edging tool.

Prior to the removal of the forms, the surface shall be finished true to grade by means of a straightedge float, not less than 10 feet in length, operated longitudinally over the surface of the concrete. Form clamps and braces shall be so constructed as not to interfere with the operation of this float.

Immediately after removing the front curb forms, the face of the curb shall be troweled smooth to a depth of not less than 0.17 feet below the flow line or to the flow line of integral curb and gutter, and then finished with a steel trowel. The top shall be finished and the front and back edges rounded as shown on the plans. After the face of the curb has been troweled smooth the entire curb and gutter surface shall be given a final fine brush finish with brush strokes parallel to the line of the curb. All slabs shall have a medium brush finish perpendicular to the direction of travel.

- B. Type II Finish (Exposed Fine Aggregate): When an exposed fine aggregate finish is specified a set retardant shall be sprayed on flat surfaces after the concrete has been placed and on forms prior to concrete placement for vertical faces. After concrete has set, usually the next day, forms are to be stripped and the surfaces to be exposed are to be sprayed with a high-pressure hose and brushed to expose the aggregate. The final exposed aggregate surface shall be cleaned and be uniform in texture. Areas where the aggregate is not exposed uniformly shall be sandblasted at the Contractor's expense to produce a uniform texture.
- C. All Finishes: The top and face of the finished curb and the top and edge of the trail slab shall be true and straight, of uniform width, free from humps, sags or other irregularities. When a straight edge 10 feet long is laid on the top or face of the curb, on the surface of gutters, or on the top surface or edge of the trail slab, the surface shall not vary more than 0.01 foot from the edge of the straightedge, except at grade changes or curves.

The Contractor shall clean at his expense all discolored concrete. The concrete may be cleaned by abrasive blast cleaning or other methods approved by the Engineer.

3.10 CURING - TRAIL SURFACES

Immediately upon completion of the finishing, the concrete surface shall be kept moist at all times by fogging with an approved atomizing nozzle until the curing material is in place. Concrete shall be cured a minimum of three days.

The surface of the concrete shall be entirely covered with white polyethylene sheeting having a minimum thickness of 6 mils (.006") placed over burlap mats. The mats shall extend at least 12" beyond the edge of the slab. Prior to being placed, the mats shall be thoroughly saturated with water. The mats shall be placed and weighed so as to remain in contact with the slab surface, and shall be maintained fully wetted and in position for the full curing period. Curing shall be started as soon as the concrete has hardened sufficiently to prevent surface damage.



If the ambient temperature falls below 40° F, insulation blankets shall be used to maintain specified curing temperature and to maintain moisture in concrete. Blankets shall be lapped 8 inches minimum and be free of holes. Blankets shall be secured at laps and edges to prevent moisture from escaping.

The Contractor shall adequately barricade the site to prevent both pedestrian traffic for three days after concrete placement and vehicular traffic for seven days after concrete placement. CDOH Type 2 or Type 3 barriers for the full width of the trail slab shall be used.

All completed surfaces damaged or disfigured during this time period shall be replaced by the Contractor.

3.11 CURING - CURB, GUTTER AND SIDEWALK SURFACES

Immediately upon completion of the finishing, concrete shall be moistened and kept moist for three days, or shall be cured by the use of membrane forming curing compound. The method and details of curing shall be subject to the approval of the Engineer and shall conform with requirements of ACI 308.

The Contractor shall adequately barricade the site to prevent both pedestrian traffic for three days after concrete placement and vehicular traffic for seven days after concrete placement.

All completed surfaces damaged or disfigured during this time period shall be replaced by the Contractor.

3.12 CURB MACHINE

Curb and gutter may be constructed with a curb machine provided the final product is of equal quality to that required by these specifications. The use of a continuous forming machine for the placement of the trail slab shall be allowed only if approved by the Engineer. The end product must exhibit smooth curve transitions and will have many locations with radii of less than 50 foot. Irregular transitions or deviations from the intended end product will not be acceptable and must be replaced at the Contractor's expense.

PART 4 MEASUREMENT AND PAYMENT

4.1 SAWCUT CONCRETE SURFACE

No separate measurement or payment will be made for the work under this item. The cost shall be included in other bid items.

4.2 CURB AND GUTTER

Measurement for payment shall be on a per linear foot basis. Payment shall be per the appropriate unit price bid item.

4.3 TRAIL SURFACES

Concrete Trail Slab: Measurement for payment of concrete trail slab surface installation or replacement shall be per square yard.

4.4 SIDEWALK SURFACES

Concrete Sidewalk: Measurement for payment of concrete sidewalk surface installation or replacement shall be per square yard.



SECTION 2730 STREET SIGNS

PART 1 GENERAL

1.1 DESCRIPTION

The work included under this section shall consist of providing and installing street/road signs as indicated on the Drawings or as directed.

1.2 QUALITY ASSURANCE

All work shall be done in accordance with the requirements of the "Manual on Uniform Traffic Control Devices for Streets and Highways", (MUTCD); Federal Highway Administration FHWA), 2009 Edition of the MUTCD with Revisions Numbers 1 and 2 incorporated, dated May 2012 and the current edition of the Standard Specifications for Road and Bridge Construction, CDOT, State of Colorado.

PART 2 PRODUCTS

POSTS

Unless otherwise noted, posts shall be either uniform flanged, channel section (U-shaped), structural steel, or timber.

PART 3 EXECUTION

Comply with provisions of Part 1.2. Coordinate with the Engineer and the Owner prior to sign installation for the exact location of each sign.

PART 4 MEASUREMENT AND PAYMENT

Payment shall be per sign installed, including all materials, assembly and installation.



SECTION 2821
REVEGETATION

PART 1 GENERAL

1.1 DESCRIPTION

- A. Work included: This specification shall govern the work associated with the revegetation of all areas disturbed by the Contractor, both on and off site, and not scheduled for revegetative treatment in plans or specifications by others. Revegetation shall include application of native or lawn seed, fertilizer, mulch, and crimping or otherwise anchoring of the mulch in place. The re-spreading of topsoil to a 4" depth on disturbed areas to be reseeded and preparation of topsoil for seeding (tracking, tilling, etc. as necessary) shall also be included in this specification if not found elsewhere.
- B. Related Work described elsewhere:

Special Provisions, Section 1567, Erosion and Sediment Control
- C. See architectural and landscape plans and specifications for related work not specified herein.

SUBMITTALS

- A. Seed and Fertilizer: The Contractor shall submit the seed and fertilizer mix proposed for use on the project for approval prior to application. All fertilizer shall conform to the Colorado Fertilizer Law in labeling and formulation. All seed shall be certified by the supplier to meet the Colorado Seed Law and tagged in accordance. All seeding rates shall be calculated by Pounds Pure Live Seed. Any changes of species due to unavailability or incompatibility to the site shall be proposed at least 48 hours in advance of beginning the work.
- B. Sod: The Contractor shall submit a sample of the sod he proposes to furnish. The sample shall serve as the standard for the project. Sod furnished which is not compatible with the standard sample will not be accepted.
- C. Hydraulic Mulch: Suppliers shall certify that laboratory and field testing of their product has been accomplished and that it meets the material requirements contained herein. Test results shall be made available to the Engineer upon written request.
- D. Tackifier: Suppliers shall certify that laboratory and field testing of their product has been accomplished and that it meets the material requirements contained herein. Test results shall be made available to the Engineer upon written request.
- E. Bonded Fiber Matrix: Suppliers shall certify that laboratory and field testing of their product has been accomplished and that it meets the material requirements contained herein. Test results shall be made available to the Engineer upon written request.



PART 2 PRODUCTS

2.1 MATERIALS

- A. Native Seed: shall consist of a mixture of the following:
*PLS=Pure Live seed

Perennial Rye (Pennfine)	10 lbs. PLS/ac.
Crested Wheatgrass (Fairway)	5 lbs. PLS/ac.
Hard Fescue (Durar)	20 lbs. PLS/ac.
Streambank Wheatgrass (Sodar)	<u>15 lbs.</u> PLS/ac.
Total	50 lbs. PLS/ac.

- B. Lawn Seed: Seed to be applied to lawn areas shall be a mixture of:

- 1/4 lb. PLS Merion Bluegrass,
- 1/4 lb. PLS Park Bluegrass, and
- 1/2 lb. PLS Perennial Rye.

- C. Sod: Bluegrass sod shall be nursery grown, 99% Kentucky Bluegrass and 99% weed free. The 1% allowable weeds shall not include any undesirable perennial or annual grasses or plants. Soil thickness of sod cuts shall not be less than 3/4 inch nor more than 1 inch. Sod shall be cut in uniform strips 18 inches in width and not less than 6 feet long.

- D. Fertilizer: The fertilizer shall be a granular type fertilizer, (11-52-0).

E. Mulch

1. Straw mulch: shall consist of straw of oats, barley, wheat, or rye which does not contain seed of normal growth of the grass or noxious weeds. Straw in such an advanced stage of decomposition as to retard the normal growth of grass or old dry straw which breaks in the crimping process in lieu of bending will not be accepted.
2. Hay mulch: shall consist of good clean field or marsh hay, having a 50 % minimum of total weight in fiber length of 8" and free of noxious weeds as listed in the Colorado Seed Law. Hay in such an advanced stage of decomposition as to smother or retard the normal growth of grass will not be accepted.
3. Hydraulic mulch: Wood cellulose fiber for hydraulic mulch shall not contain any substance or factor that might inhibit germination or growth of grass seed. It shall be dyed an appropriate color to allow visual metering of its application. The wood cellulose fibers shall have the property of becoming evenly dispersed and suspended when agitated in water. When sprayed uniformly on the surface of the soil, the fibers shall form a blotter-like ground cover that readily absorbs water and allows infiltration to the underlying soil. Weight specifications from suppliers, and for all applications, shall refer only to air dry weight of the fiber, a standard equivalent to 10 percent moisture. The mulch material shall be supplied in packages having a gross weight not in excess of 100 pounds and shall be marked by the manufacturer to show the air-dry weight content.



F. Tackifier:

1. Shall be a guar- based product which will not inhibit germination or growth of plants.
2. Capable of being used either alone or in combination with wood fiber mulch, fertilizer or other approved additives.
3. Asphalt tackifier is not acceptable.

G. Bonded Fiber Matrix

Bonded fiber matrix shall be Soil Guard, as manufactured by Mat, Inc. or reviewed equal.

PART 3 EXECUTION

3.1 PREPARATION

- A. General: In all disturbed areas, topsoil is to be salvaged and replaced at a nominal 4" depth. If a topsoil deficiency exists, topsoil shall be imported. On slopes steeper than 3:1 (h:v) topsoil shall be no deeper than 3".
- B. Prior to any revegetation activity, the topsoil shall be lightly compacted by means of "walking" the slope vertically with a dozer to create a cleared track compaction. A sheepsfoot roller may also be used for this compaction. If topsoil surface is smooth, topsoil shall be scarified by tilling or other methods which will result in seed pockets and lightly compacted soil.
- C. Sod: Preparatory to sod placement, all irregularities in the ground surface shall be removed. Sticks, stones, debris and other similar material more than 1/2 inch in diameter shall be removed. Any objectionable depressions or other variances from a smooth grade shall be corrected. Areas to be sodded shall be smooth before any sod is placed.

3.2 APPLICATION

A. Pre-measurement:

Areas for treatment shall be pre-measured in order to uniformly apply materials.

B. Native Seed:

1. Seeding shall be applied at the rate of 50 lbs. PLS/acre or approximately 1-pound PLS/1000 square feet. Seeding shall be accomplished by means of an approved drill-type seeder whenever possible. Otherwise seed shall be sown with an approved broadcast-type seeder or by hydraulic seeding.
2. Seeding Period and Maintenance: It is preferred that native seeding be accomplished before May 15th or after August 15th. Seeding may be done between May 15th and August 15th but this may require considerable additional watering by the Contractor to assure adequate revegetation. If seed is to be sown between May 15th and August 15th, the Contractor shall be responsible for maintaining and adequately watering seeded areas during the warranty period of five weeks after the time of seeding. Areas in which there is not a satisfactory stand at the expiration of the five-week period shall be reseeded once to provide acceptable revegetation at the end of the warranty period. Seed shall not be sown during windy weather or when the ground is frozen or otherwise un-tillable.

- C. Lawn Seed: Seeding shall be accomplished by means of an approved broadcast-type seeder at a rate of 1 lb. per 300 sq. ft. PLS. The seeded area shall then be raked to provide about 1/4 inch of cover over the seed unless hydraulic broadcasting and mulching is used. Seed shall not be sown

Revegetation

Town of Hayden – 1/06

2821-3



during windy weather or when the ground is frozen or otherwise un-tillable.

The Contractor shall be responsible for maintaining and watering seeded lawn areas for a period of five weeks after the time of seeding. The Contractor shall guarantee that a stand of grass exists after the five-week period. If areas or patches exist without a satisfactory stand of grass, the Contractor shall reseed and maintain until a satisfactory stand exists.

- D. Sod: The sod shall be laid by staggering joints. On any slopes, the sod shall run parallel to a 90-degree angle to the slope. After installation, the sod shall be thoroughly soaked.

After soaking, the sod shall be permitted to dry to the point where it is still wet enough for effective rolling. It shall then be rolled in two directions with a lawn roller weighing not less than 150 pounds to secure a tight bond of sod to subgrade and between strips.

The Contractor shall be responsible for maintaining and watering sodded areas for a period of five weeks after the placement of sod. The Contractor shall guarantee the sod and any areas of dead or dying sod shall be replaced and maintained until it is self-sufficient.

- E. Fertilizer:

The fertilizer shall be a granular type, incorporated into the top 4 inches of the soil at a rate of 6 pounds per 1000 square feet of surface area.

- F. Mulching:

1. General: All mulching procedures shall be done after the seeding operation is completed and not in conjunction with seeding. Mulching is not required for areas to be covered with soil retention blankets, except as may be required for hydraulic seeding slurries. Hay mulch shall not be used in lawn areas.
2. Hay or straw mulch: Hay or straw shall be spread evenly over the seeded surface at a rate of 2 tons per acre (approximately 1.5 bales per 1000 square feet) and shall be crimped into the soil with approved equipment. On steep slopes where crimping is not possible a tackifier shall be applied at the rate of 150 pounds per acre to prevent mulch from blowing away.
3. Hydraulic mulching: The hydraulic mulching material shall be spray applied to the seeded area at a rate of 1,500 pounds/acre. Hydraulic mulching shall not be done in the presence of free surface water resulting from rain, melting snow or other causes.
4. Mulch rates may be reduced (hydraulic mulching) or eliminated (hay or straw mulch) if bonded fiber matrix will be used. Contractor shall submit proposed slurry mix proportions for review at least 48 hours prior to application.

- G. Bonded Fiber Matrix

1. Bonded fiber matrix shall be applied to seeded areas within 48 hours of seeding, at a rate of 3,500 pound per acre.
2. Application shall be by a Contractor certified by the manufacturer in the proper procedures for mixing and application of the product.



PART 4 MEASUREMENT AND PAYMENT

4.1 NATIVE OR LAWN SEED APPLICATION

Payment shall be per acre seeded per the appropriate Bid item and is to include all work related to preparation and seed application. The Contractor shall supply the Engineer with all weight and mixture tickets for native seeding materials used.

4.2 SOD

Payment shall be made per square yard per the appropriate Bid item and is to include all work related to preparation and installation.

4.3 FERTILIZER

Payment shall be per acre fertilized per the appropriate Bid item and is to include all work related to preparation and fertilizer application. The Contractor shall supply the Engineer with weight tickets for fertilizer used.

4.4 MULCH

Payment for mulch application shall be per acre mulched per the appropriate Bid item. The Contractor shall supply the Engineer with weight verification for all mulch materials used. Areas not properly mulched or damaged due to the Contractor's negligence, shall be repaired and re-mulched in an acceptable manner at the Contractor's expense. Mulch removed by circumstances beyond the Contractor's control shall be repaired and re-mulched as ordered. Payment for this corrective work shall be at the unit Bid price.

4.5 TACKIFIER

Payment shall be per acre of applied tackifier per the appropriate Bid item and is to include all work related to preparation and tackifier application. The Contractor shall supply the Engineer with tickets for tackifier used.

4.6 BONDED FIBER MATRIX

Payment shall be per acre of bonded fiber matrix applied per the appropriate Bid item and is to include all work related to preparation and bonded fiber matrix application. The Contractor shall supply the Engineer with tickets for bonded fiber matrix used.

4.7 TOPSOIL

Payment for re-spreading and preparing topsoil, if determined under this specification, for reseeding shall be paid made at the contract unit price per cubic yard in place.

4.8 LIMITATIONS

The Contractor will not be paid for revegetation of disturbed areas which resulted from the Contractor's carelessness or negligence in performing the Work.

**TOWN OF HAYDEN
DETAILS
January, 2019**



178 W. Jefferson Ave.
P.O. Box 190
Hayden, CO 81639
Office: 970-276-3741

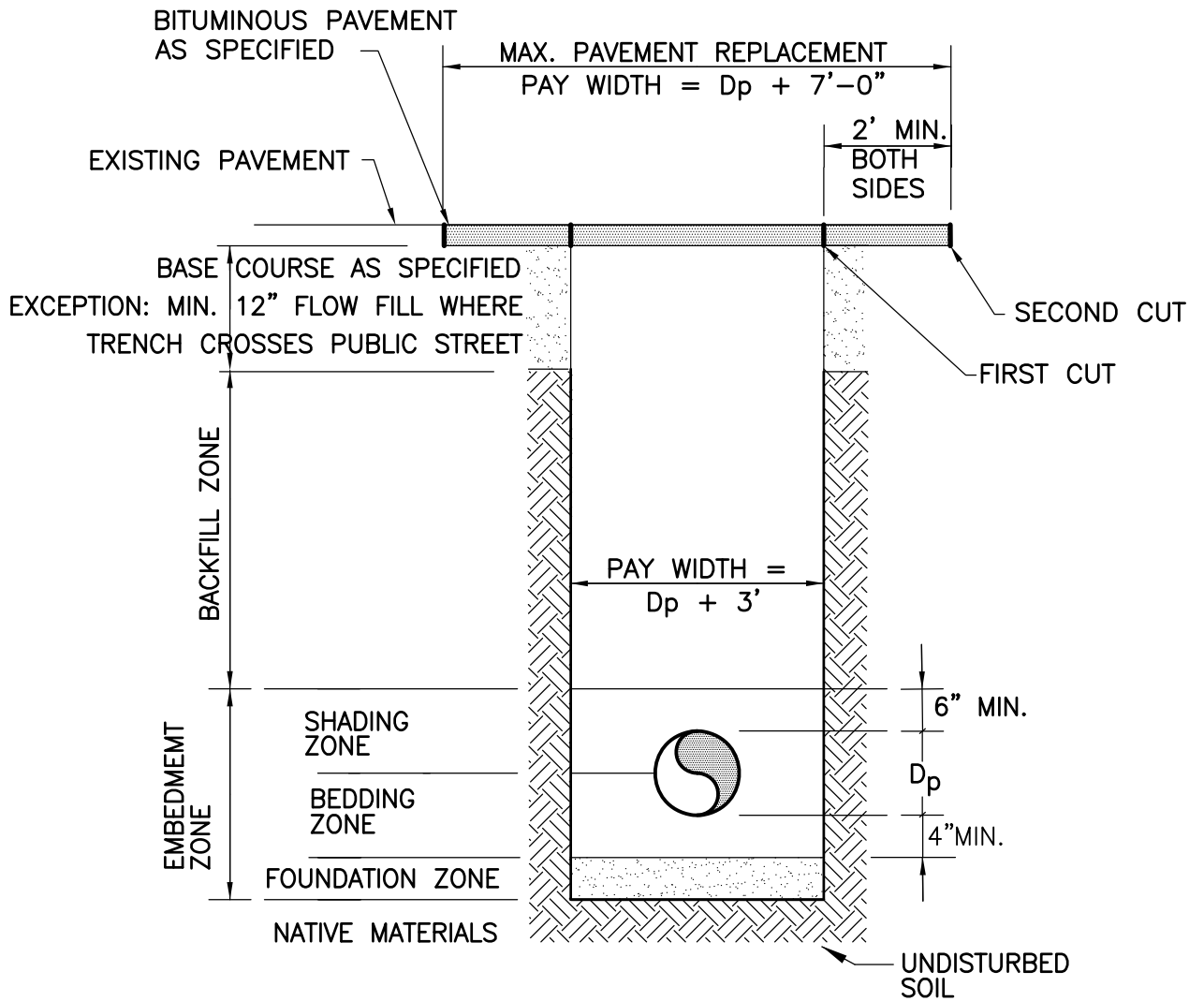

Condition #1: New Water Main less than 18" above New Sewer Main

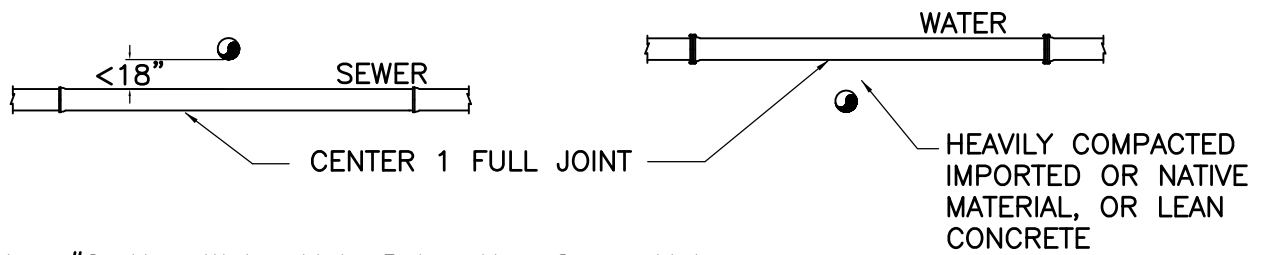

Condition #2: New Water Main Below New Sewer Main

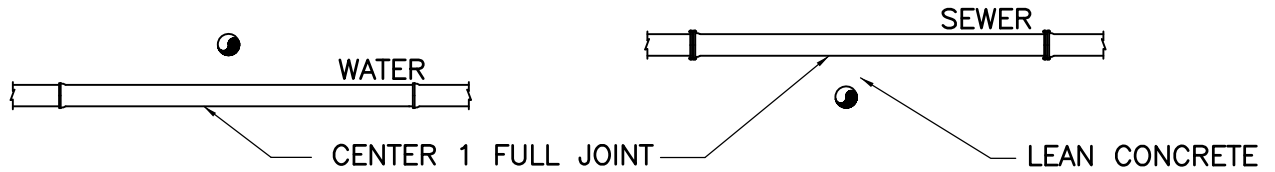

Condition #3: New Water Main less than 18" above Existing Sewer Main

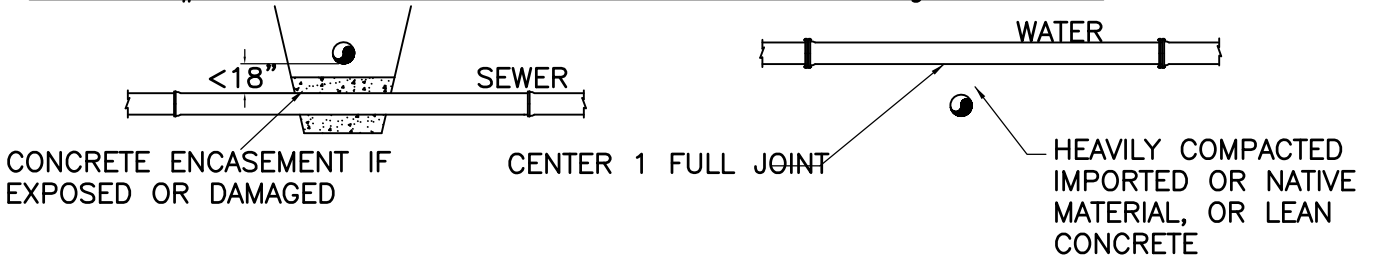

Condition #4: New Water Main Below Existing Sewer Main

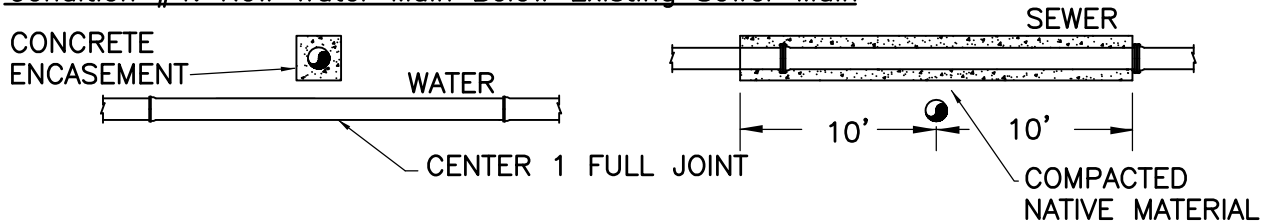

Condition #5: New Sewer Main less than 18" below Existing Water Main

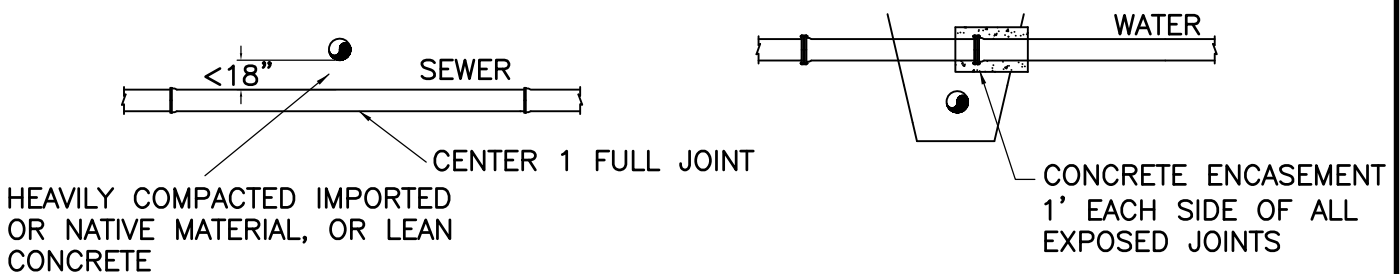

Condition #6: New Sewer Main Above Existing Water Main

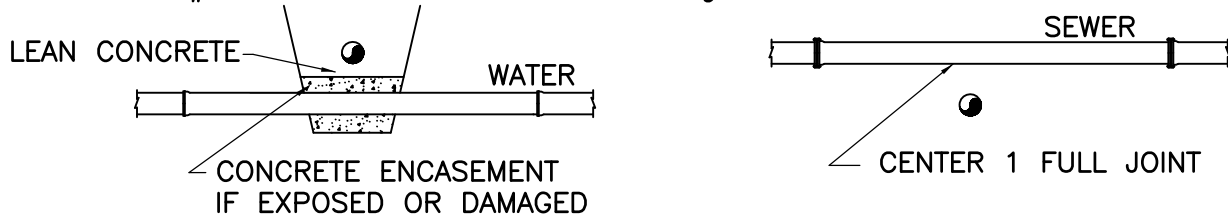

NOTES:

1. ENGINEER SHALL OBSERVE INSTALLATION OF ALL PIPE, FITTINGS, COUPLINGS, AND GRADE PRIOR TO BACKFILL.
2. INSTALL AND COMPACT ALL BACKFILL MATERIAL PER SPECIFICATIONS AND AS SHOWN WITHIN THE TRENCH CROSS SECTION AND PIPE EMBEDMENT DETAIL.
3. RUBBER GASKETED BELL AND SPIGOT TYPE COUPLER FOR TRANSITION FROM SCHEDULE 40 PVC TO SDR35.
4. ALL PVC FITTINGS SHALL MEET ASTM D3034 SPECIFICATIONS, AND SHALL ALSO MEET ASTM D3212 SPECIFICATIONS FOR RUBBER GASKETED BELL AND SPIGOT TYPE WITH INTEGRAL BELL.

MINIMUM PIPE SLOPES FOR SEWER SERVICES		
4"	1/4" PER FOOT	2%
6"	1/8" PER FOOT	1%
8"	1/16" PER FOOT	0.5%

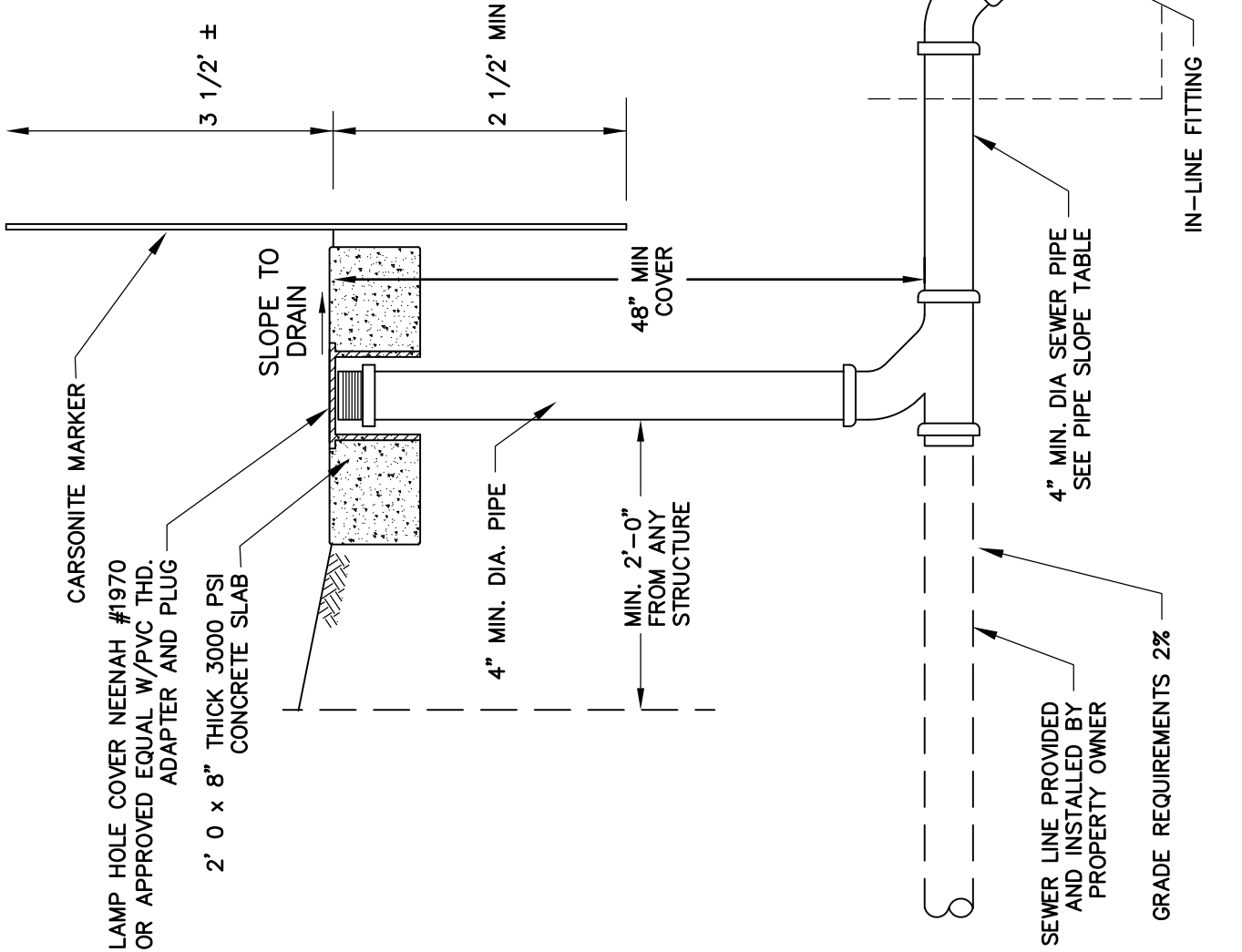

ALL MANHOLE MATERIALS AND FABRICATION SHALL BE IN ACCORDANCE WITH ASTM C 478. ALL MANHOLES ARE 48"Ø UNLESS INDICATED OTHERWISE ON PLANS. SEE SECTION 2523 - "MANHOLES" FOR ADDITIONAL REQUIREMENTS.

IF STUB-OUT IS INDICATED PLACE BELL SECTION WITH PLUG AND EXTEND 6" MINIMUM BEYOND BASE

USE MAXIMUM RADIUS TO PROVIDE SMOOTH TRANSITION

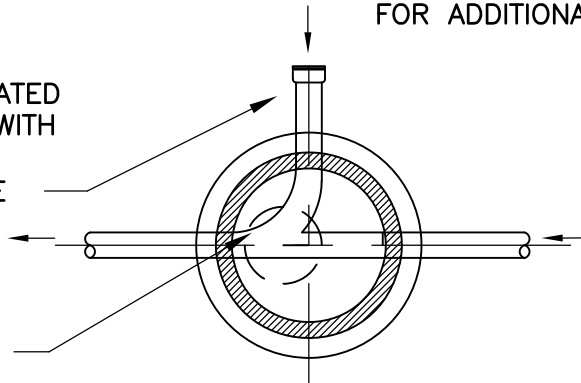

PLAN VIEW

GROUND SURFACE TREATMENT AND LID PLACEMENT PER SPECIFICATIONS

POSITION COVER AND STEPS TO PROVIDE BEST ACCESS TO BENCH OR PER ENGINEER

FLEXIBLE RUBBER BOOT IN CORED HOLE PER ASTM C 923; "KOR-N-SEAL", "A-LOK" OR APPROVED EQUAL

SEWER PIPE PER PLANS

IMPORTED FOUNDATION MATERIAL

UNDISTURBED NATIVE MATERIAL

SEWER MARKER POST

AS REQUIRED - 1' MAXIMUM, GROUT ALL GRADE RINGS

MANHOLE STEPS AT 16" MAX.

RUB'R-NEK OR APPROVED EQUAL AT ALL JOINTS, SEE SPECS.

SLOPE BENCH 1 INCH/FOOT

SECTION VIEW

MANHOLE INVERTS AND SLOPE PER ELEVATIONS ON PLANS

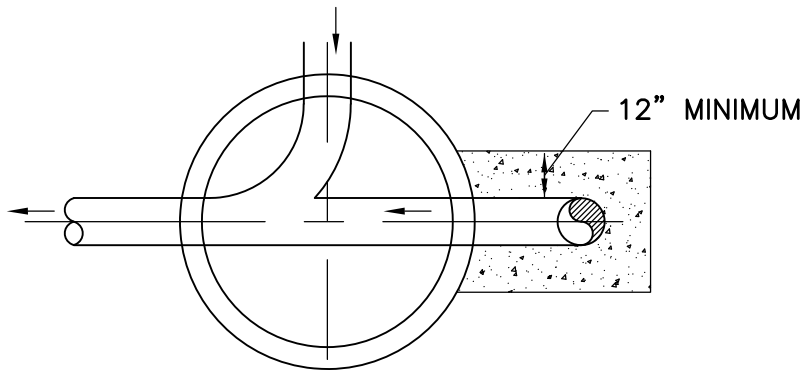

PLAN VIEW

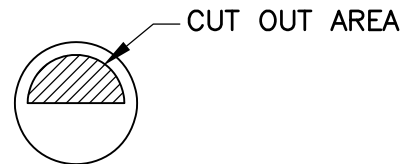

VIEW CAP
END VIEW

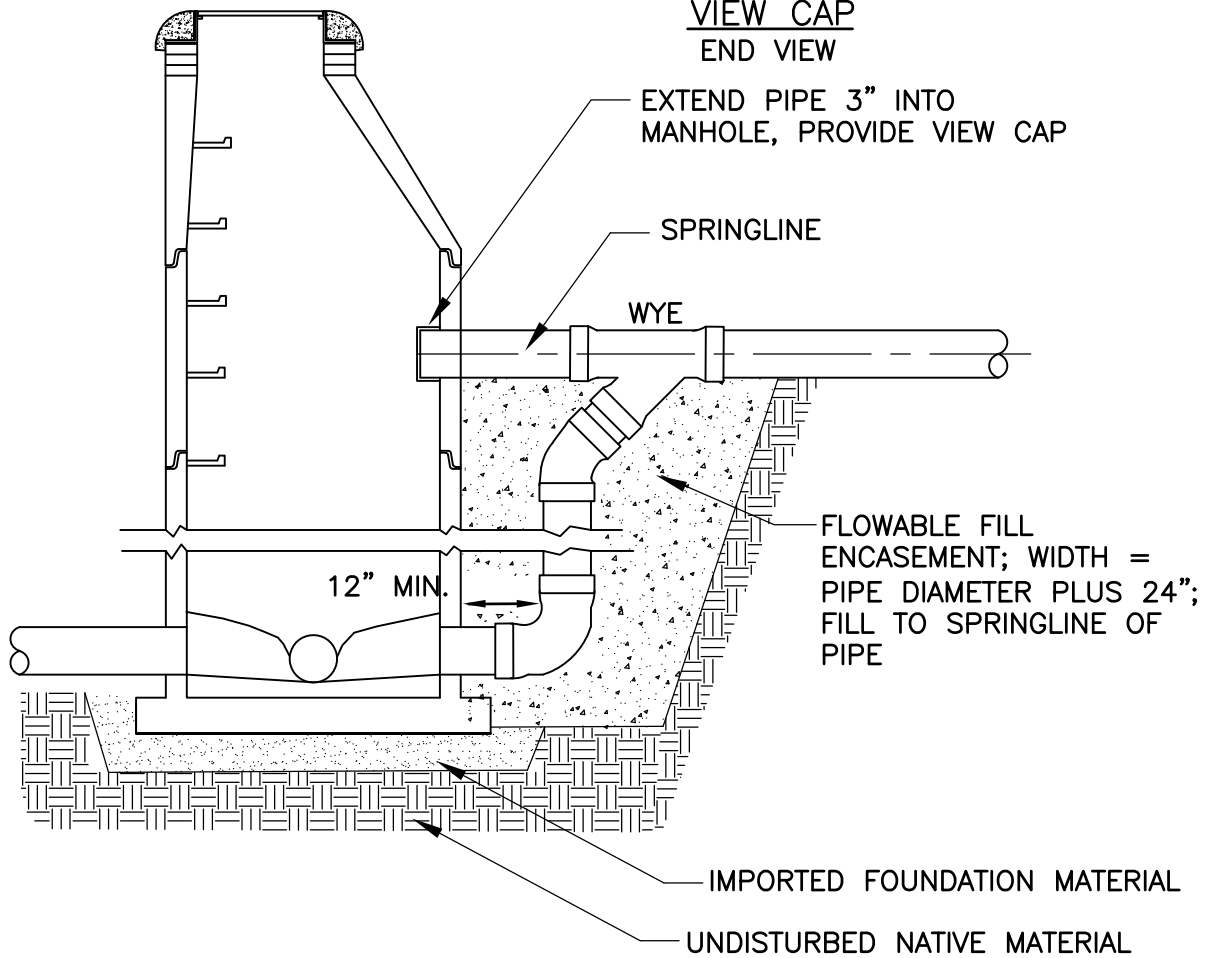

SECTION VIEW

SEE STANDARD MANHOLE DETAIL
FOR ADDITIONAL DETAILS

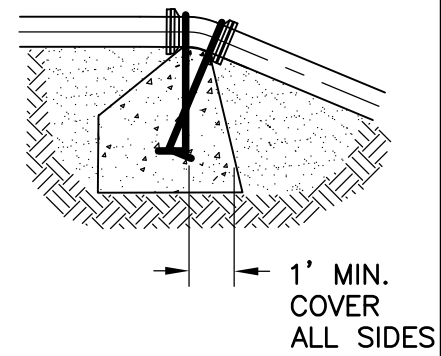
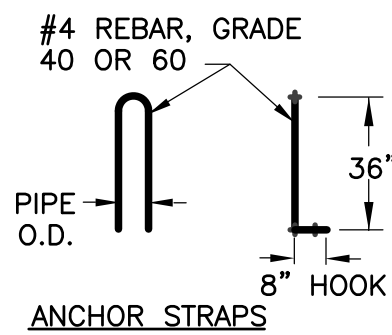
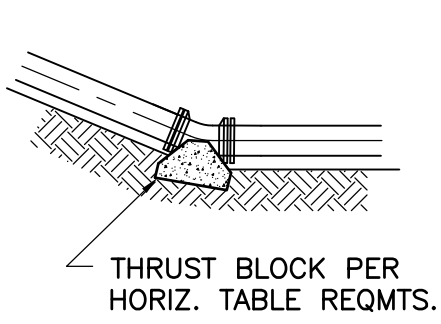

VERTICAL UNDER-BEND

VERTICAL OVER-BEND

NOTES:

1. FOUR (4) TOTAL ANCHOR STRAPS REQUIRED, (2) EACH SIDE OF THE BEND.
2. COAT EXPOSED STEEL WITH (2) COATS BITUMINOUS COATING.
3. MINIMUM EMBEDMENT DEPTH = 1 FT.
4. MINIMUM SINGLE DIMENSION ON ANY ONE SIDE = 3 FT.
5. CONCRETE SHALL BE 3,000 PSI.
6. PLACE POLYETHYLENE BARRIER BETWEEN PIPE AND CONCRETE.
7. THRUST BLOCKS SHALL BEAR AGAINST FIRM UNDISTURBED EARTH.
8. TABLES BASED UPON MAIN PRESSURE PLUS WATERHAMMER AND 2,000 PSF SOIL BEARING PRESSURE. ADJUST BEARING AREAS IN ACCORDANCE WITH PRESSURES AND SOIL CONDITIONS. SEE SPECIFICATIONS.
9. THE BEARING AREA OF ALL THRUST BLOCKS WILL BE MEASURED PRIOR TO POURING.
10. JOINT RESTRAINT IS REQUIRED IN ADDITION TO THRUST BLOCKS.

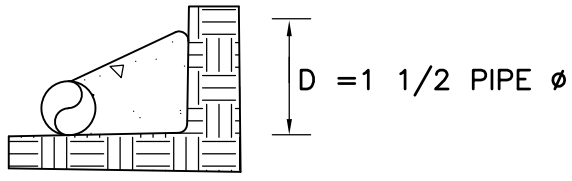

CROSS SECTION

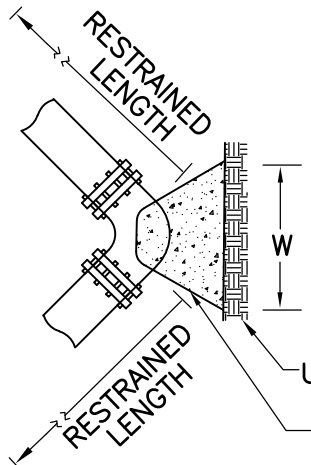

BEND

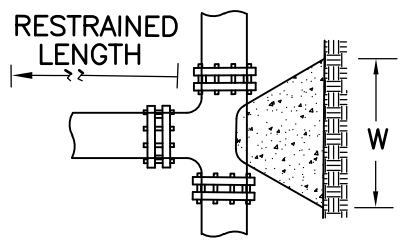

TEE

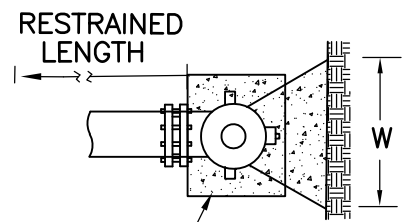

DEAD END OR FIRE HYDRANT

NOTES:

1. JOINT RESTRAINT IS REQUIRED IN ADDITION TO THRUST BLOCKS.
2. THRUST BLOCK AND RESTRAINT ARE DEPENDENT ON LINE PRESSURE. SEE SPECIFICATIONS.

No Mueller H-10342. Need to have 5 1/2 Valve Box Riser if in concrete or asphalt with curbstop inset.

~~MUELLER H-10342~~ CURB BOX SLEEVE OR EQUIVALENT, SUITABLE FOR CONCRETE SETTING. TOP OF LID TO BE 1/4" BELOW FINISH GRADE.

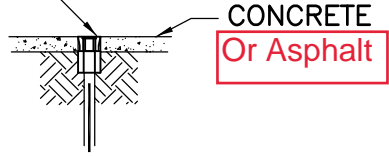

CONCRETE SETTING

INCHES	FEET
3/4"	6"
1"	7 1/2"
1 1/4"	9"
1 1/2"	10"
2"	12"

WHEN BENDING BY HAND BEND THE COPPER AROUND A CIRCULAR WOODEN DISC.

RADIUS TABLE

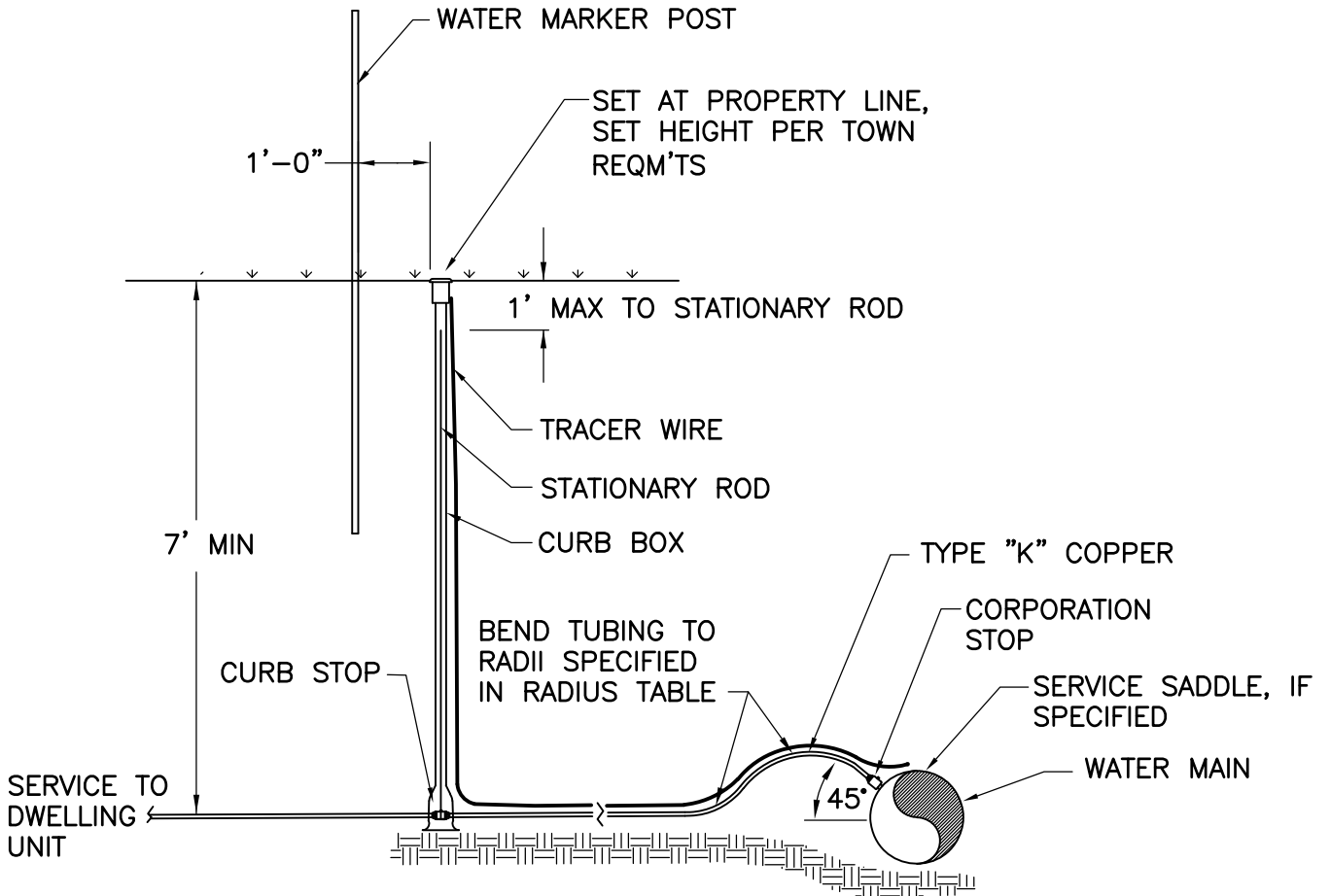

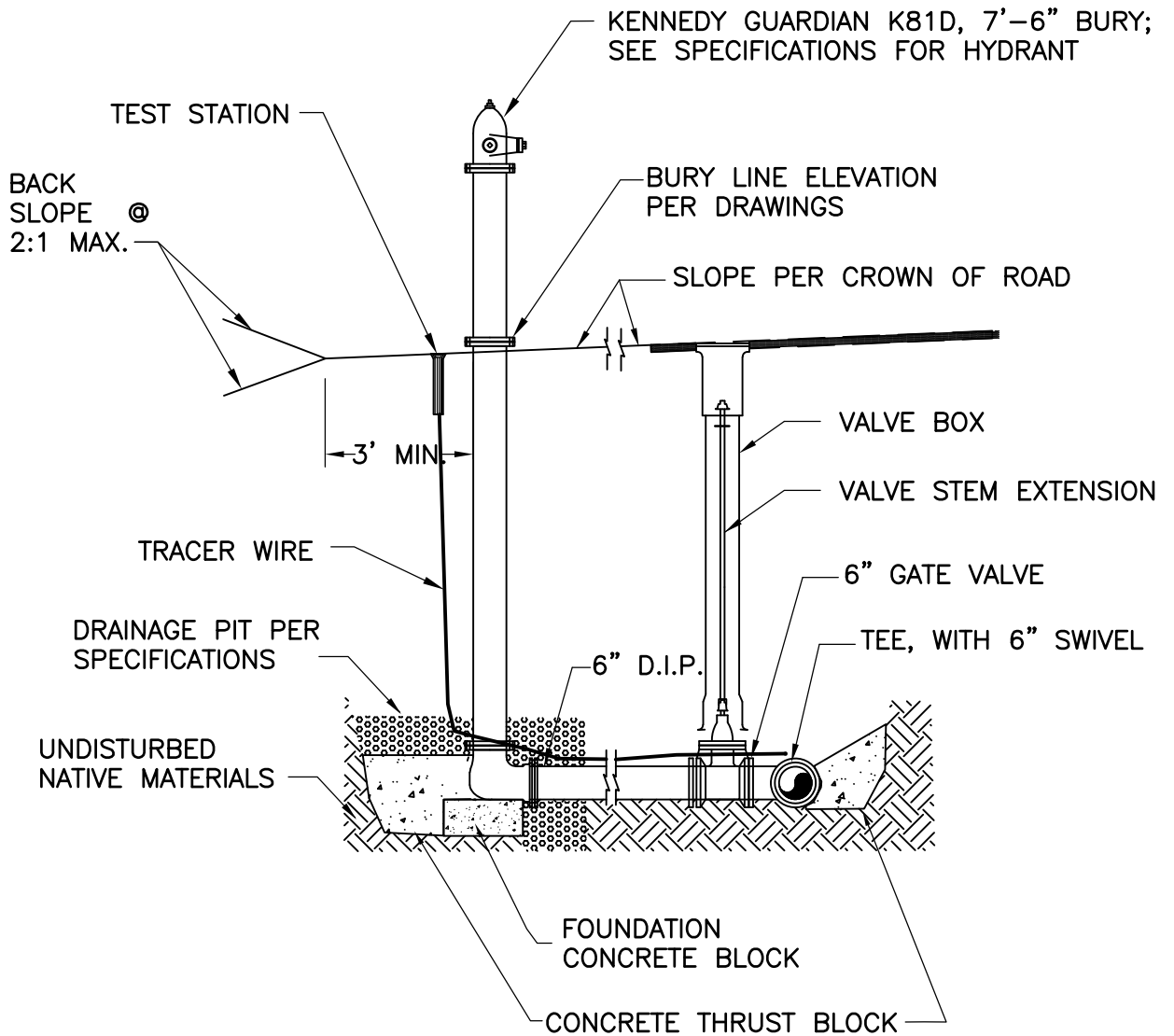

NOTES

1. ALL HYDRANT LATERAL JOINTS REQUIRE AN APPROVED JOINT RESTRAINT SYSTEM.
2. HYDRANT LATERALS REQUIRE THRUST BLOCKS AND FOUNDATION BLOCK AS SHOWN.
2. POLY ENCASE TEE, VALVE, HYDRANT AND PIPE. SEE SPECIFICATIONS.

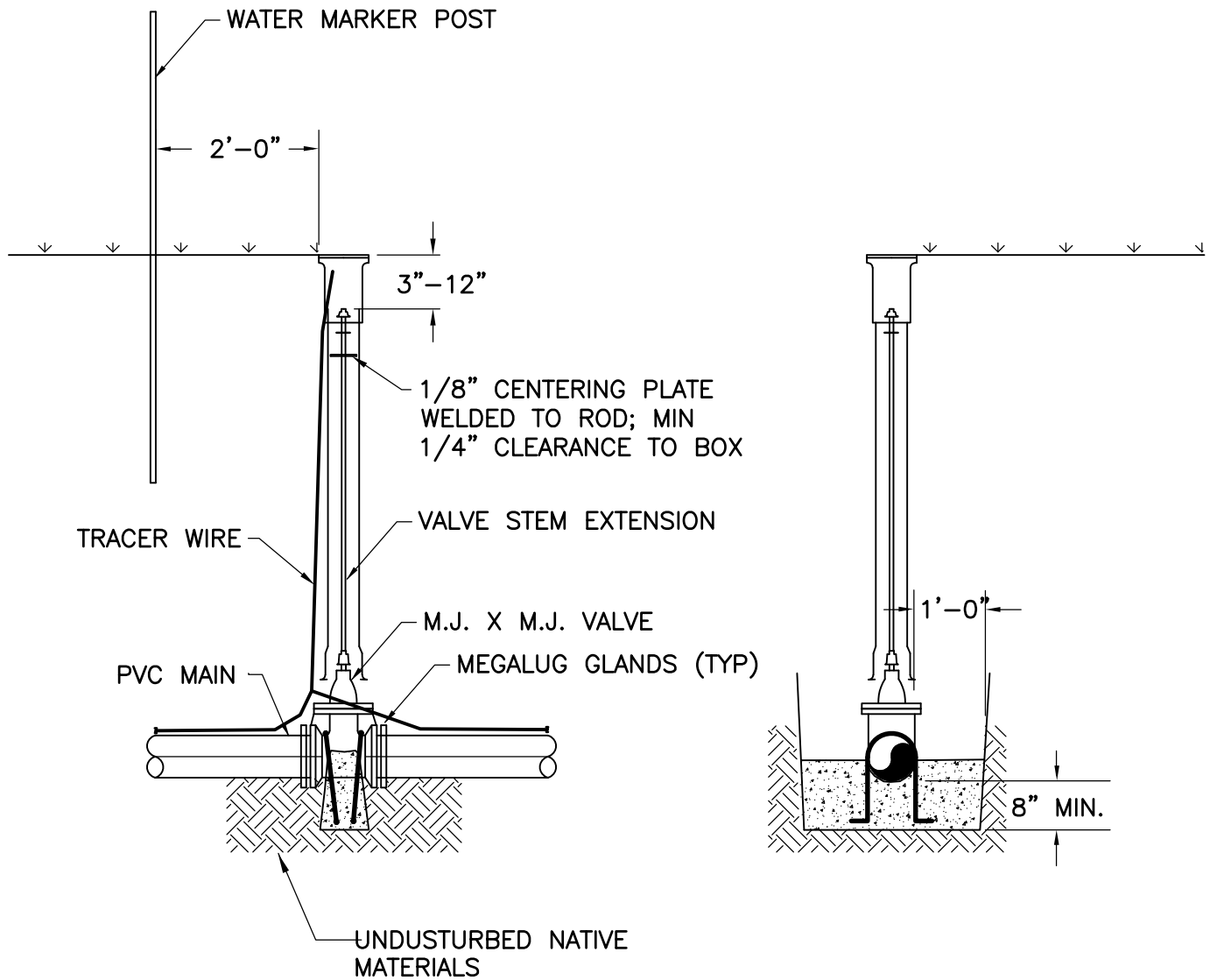

NOTES

1. CONCRETE SHALL BE 3,000 PSI.
2. PLACE POLYETHYLENE BARRIER BETWEEN PIPE AND CONCRETE.
3. THRUST BLOCKS SHALL BEAR AGAINST FIRM UNDISTURBED EARTH.
4. POLYWRAP VALVE. SEE SPECIFICATIONS.
5. SEE SPECIFICATIONS FOR TOP OF LID SETTINGS.
6. PLACE TRACER WIRE AND TEST STATIONS PER SPECIFICATIONS.
7. POLYWRAP VALVE BOX AND ALL METALIC COMPONENTS.

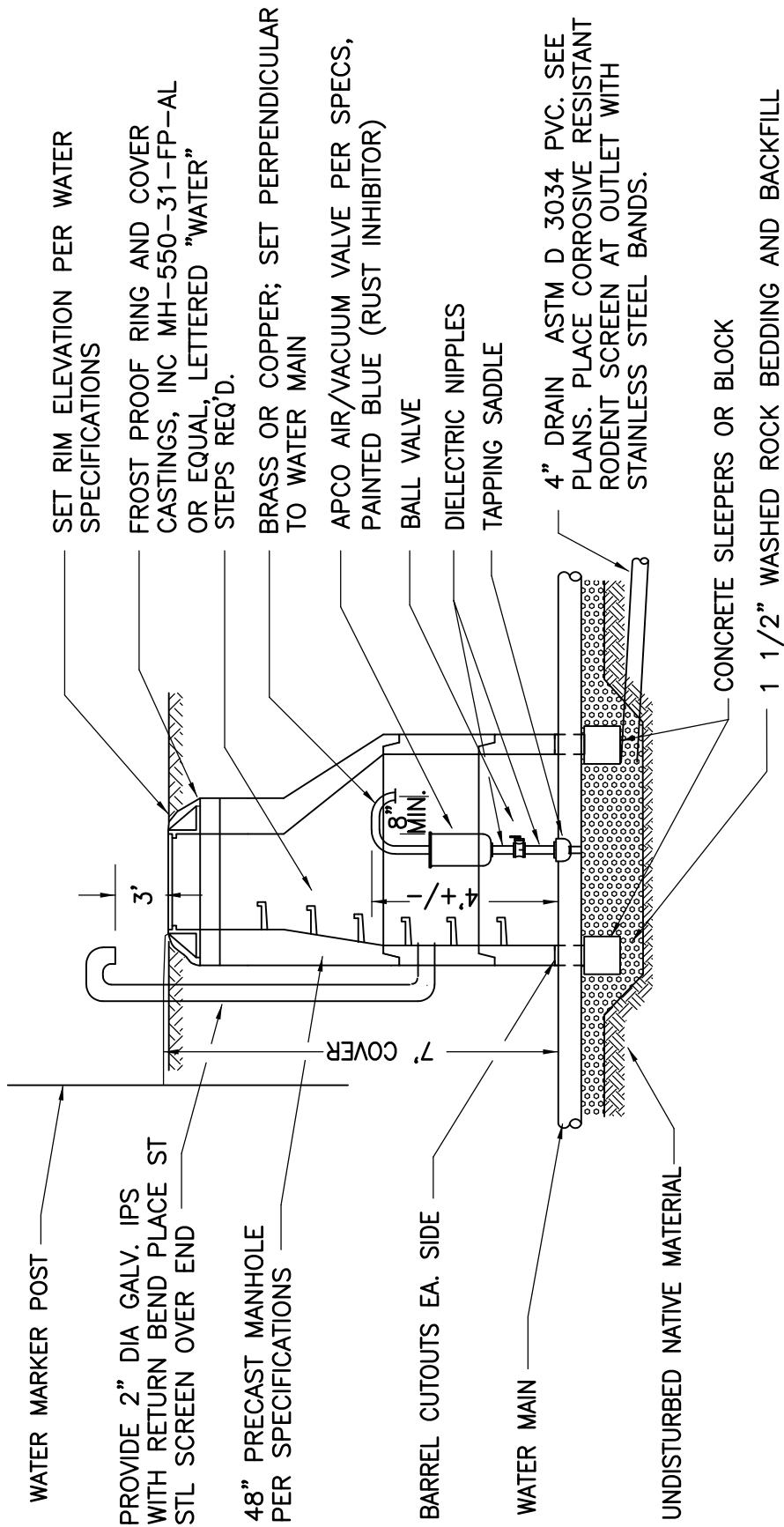

SET RIM ELEVATION PER WATER SPECIFICATIONS

FROST PROOF RING AND COVER CASTINGS, INC MH-550-31-FP-AL OR EQUAL, LETTERED "WATER" STEPS REQ'D.

BRASS OR COPPER; SET PERPENDICULAR TO WATER MAIN

APCO AIR/VACUUM VALVE PER SPECS, PAINTED BLUE (RUST INHIBITOR)

BALL VALVE

DIELECTRIC NIPPLES TAPPING SADDLE

4" DRAIN ASTM D 3034 PVC. SEE PLANS. PLACE CORROSIVE RESISTANT RODENT SCREEN AT OUTLET WITH STAINLESS STEEL BANDS.

CONCRETE SLEEPERS OR BLOCK

1 1/2" WASHED ROCK BEDDING AND BACKFILL

NOTES

1. ORIENT STEPS, RING AND COVER TO BEST FIT SITE REQUIREMENTS.
2. SEE WATER SPECIFICATIONS FOR ADDITIONAL MATERIAL REQUIREMENTS.
3. BOTTOM BARREL SECTION TO HAVE CUTOUTS W/2" MIN. CL'R. AROUND PIPE.
4. SET BOTTOM BARREL SECTION ON TWO 12"x12"x6' REINF. PRECAST CONCRETE SLEEPERS. (12" CONCRETE BLOCKS SET RADIALLY ACCEPTABLE ALTERNATE). SHADE TO SPRING LINE INSIDE M.H.
5. FOR ARV IN ROADWAY, ELIMINATE 2" VENT, 4" DRAIN TO DAYLIGHT IS REQUIRED.
6. SIZE AIR/VACUUM VALVE FOR EACH APPLICATION.

COMPONENTS LIST

ITEM	DESCRIPTION
1	"WABASH" W3-DOUBLE INSULATED LID
2	20" ϕ FORD PLASTIC PIT SETTER
3	ANGLE BALL VALVE
4	ANGLE CARTRIDGE DUAL CHECK VALVE
5	CTS PACK JOINT, FORD C4433G; 3/4"
5	CTS PACK JOINT, FORD C4444G; 1"
6	TYPE "K" COPPER TUBING
7	BRACE
8	METER
9	"WATTS USB" PRESSURE REDUCING VALVE
10	RADIO READ MOUNTED ON POST (CHECK CURRENT SPEC)
11	4" ϕ X 8' GREEN-TREATED FENCE POST
12	6" MIN. WASHED ROCK

NOTES

1. LOCATE PIT IN A WELL-DRAINED AREA.
2. SEE PLANS FOR SIZE OF SERVICE LINES AND METERS. METER SIZE TO BE DETERMINED BY THE DISTRICT.
3. METER PITS WITH PRV'S REQUIRE TANDEM SETTINGS.
4. SEE PLANS FOR SPECIFIC LOCATIONS REQUIRING PRV'S.
5. MAINTAIN 2" MINIMUM CLEARANCE BETWEEN ALL COMPONENTS AND PIT WALL.
6. GRADE AWAY FROM LID 2% MIN. FOR 3 FT. IN ALL DIRECTIONS.
7. SEE "WATER SERVICE DETAIL" FOR STREET SIDE CONTINUATION.
8. ITEMS 2-7 ARE PURCHASED PRE-ASSEMBLED FROM FORD METER BOX CO.; SEE PLASTIC PIT SETTERS, CAT. SECT. FA1. A TYPICAL SAMPLE NO. FOR THE 3/4" METER PIT WOULD BE: PTDBHC344-20-84. ALL OTHER ITEMS ARE PURCHASED SEPARATELY.
9. TYPE "K" COPPER WATER PIPE SHALL BE USED FROM THE WATER MAIN TO THE METER PIT; EITHER TYPE "K" COPPER OR HDPE CAN BE USED FROM THE METER PIT TO THE HOME.

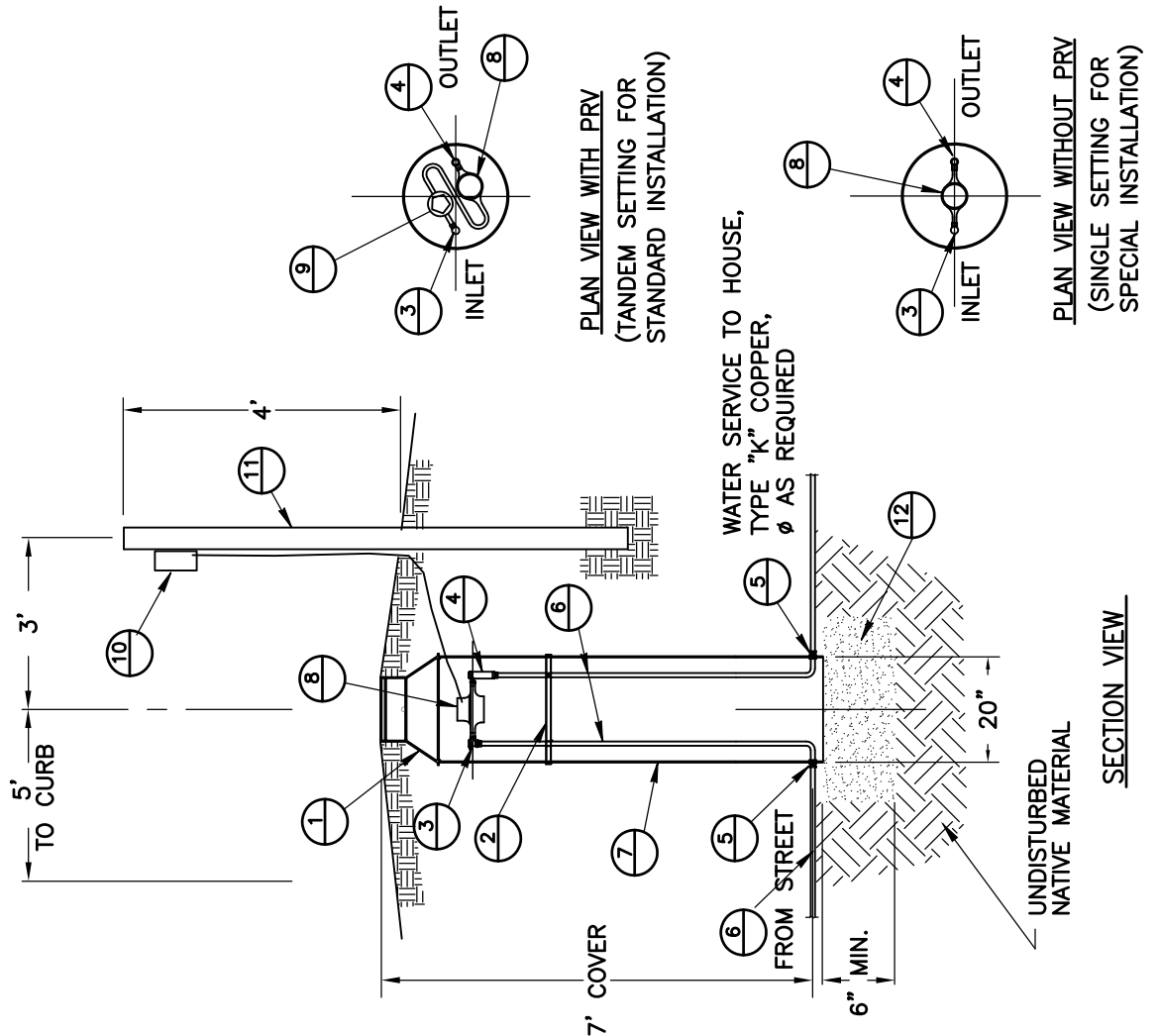

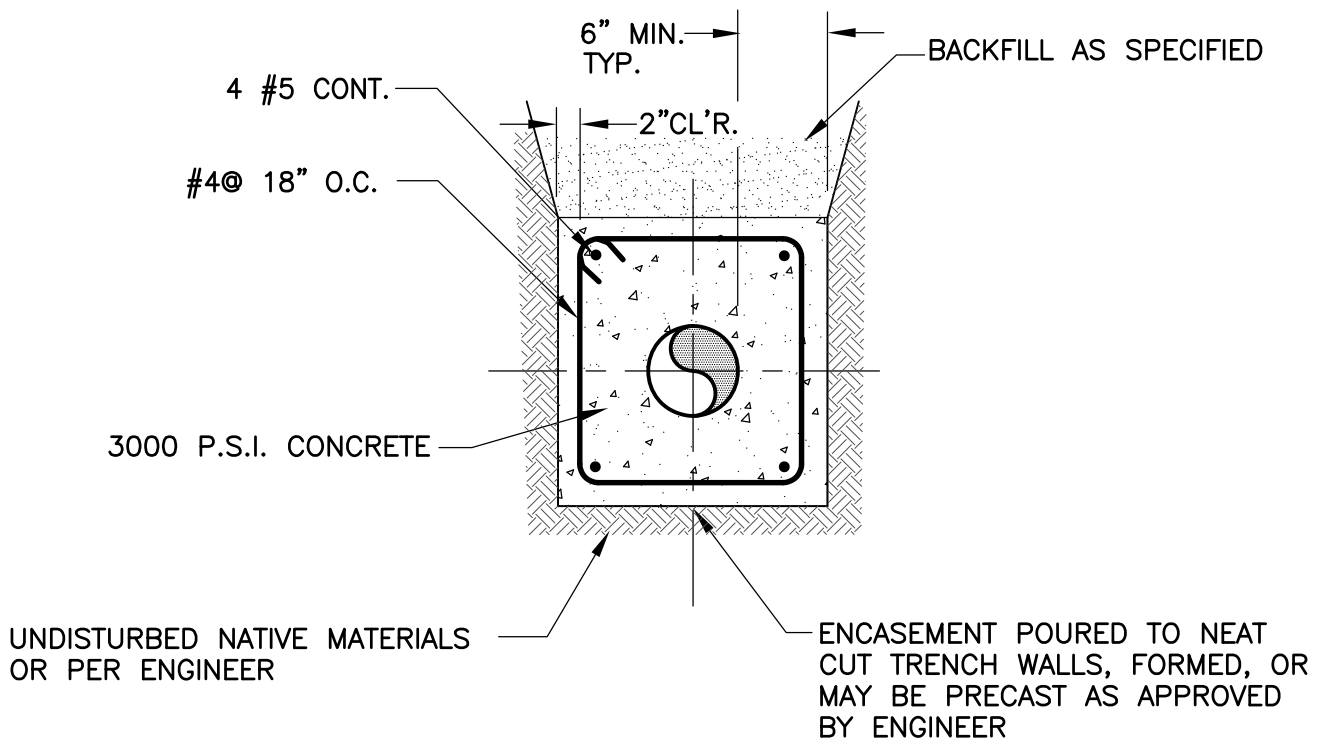

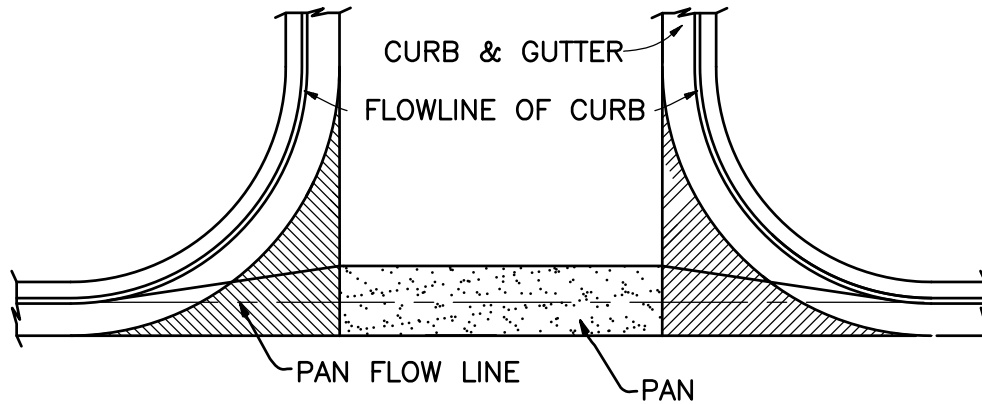

 THIS AREA SHALL BE Poured MONOLITHICALLY WITH CURB AND GUTTER AND PAID FOR AS "CONCRETE PAVEMENT."

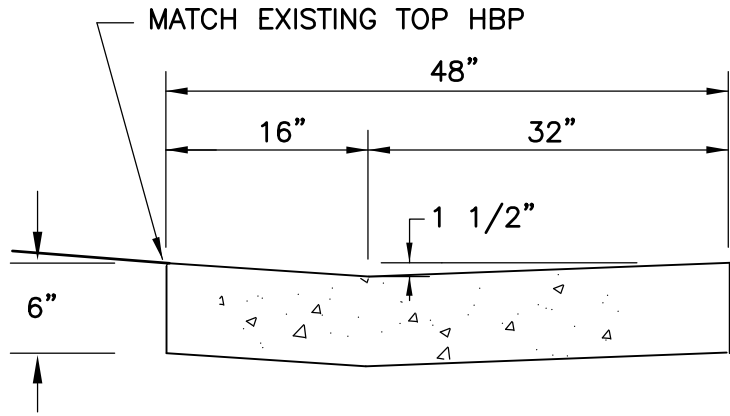

CONCRETE PAN

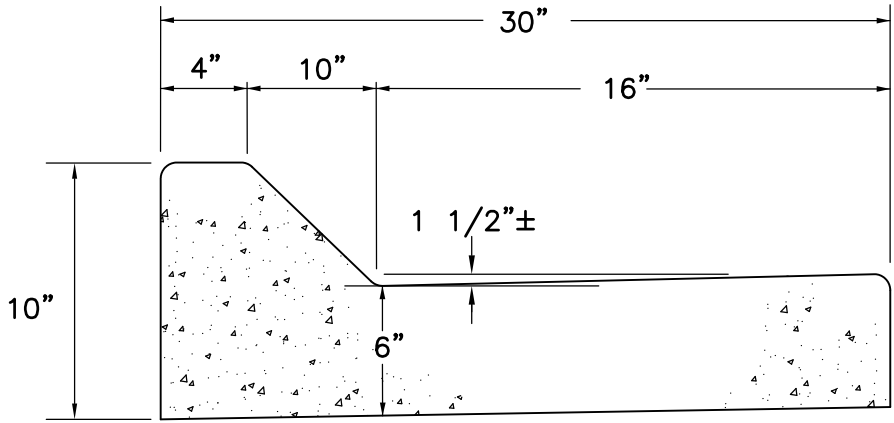

* SLOPE REVERSES FOR SPILL CURB

ALL CURBS TO BE CATCH, EXCEPT WHERE NOTED

CURB DETAIL

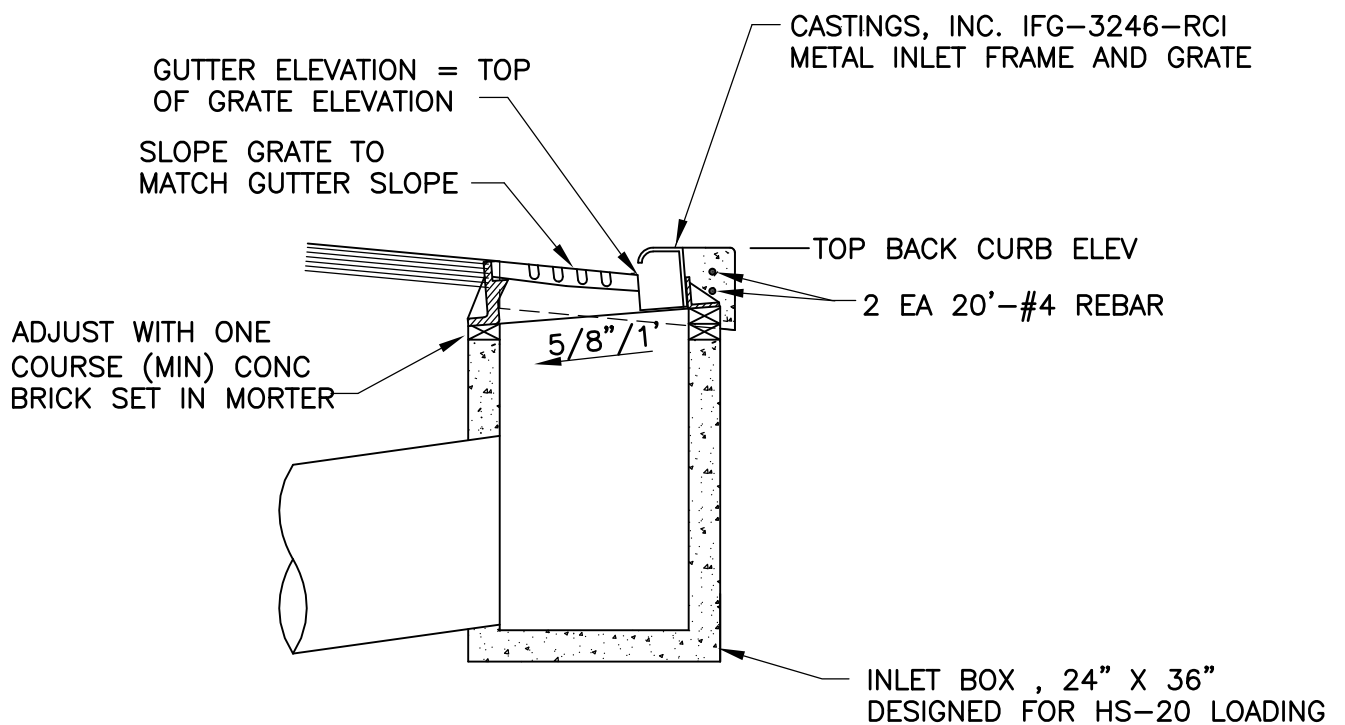

NOTES:

1. BOX SHALL BE PRECAST, AS MFCTR'D. BY AMCOR OR EQUAL.
2. CURB TO BE TRIMMED AND ADJUSTED TO MATCH BACK OF CONCRETE CURB HEIGHT. TRANSITION CONCRETE CURB AND
3. GUTTER SECTION FOR 10' EACH SIDE OF INLET TO MATCH TOP OF GRATE ELEVATION.
ADJUST DRIVE-OVER CURB BOX TO FIT CURB BACK.

INSULATED PIPE

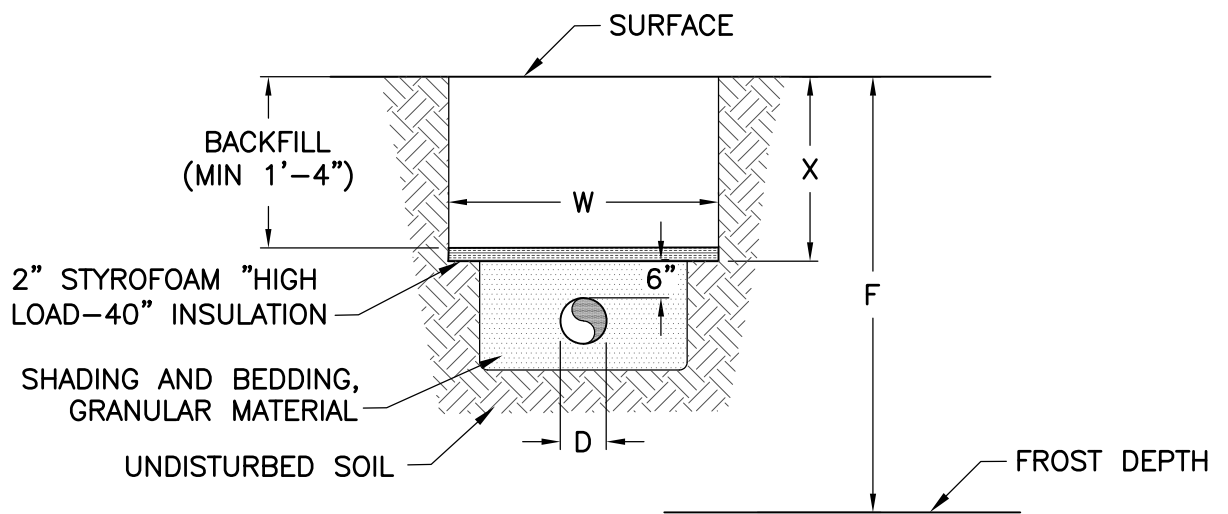

WIDTH OF INSULATION: $W=3D+2[F-(X+D+0.5')]$ (IN FT.)

WHERE: W = WIDTH OF INSULATION (FT.)

D = PIPE DIAMETER (FT.)

X = INSULATION DEPTH (FT.)

F = ESTIMATED FROST DEPTH (FT.)

*INSULATION MIN. 2" THICK

*FROM "INSULATION FOR GEOTECHNICAL APPLICATIONS"
DOW / STYROFOAM HIGH LOAD INSULATION*